

APPROVAL

PART NO.	DESCRIPTION	REMARKS
HS1501L	LCD MODULE (128 × RGB × 128)	* This is ROHS compliant

CUSTOMER APPLICATION P/N	
APPROVED BY	
DATE	

PLEASE KINDLY FIND AND APPROVE THE SPECIFICATIONS INSERTED
HEREIN AND RETURN ONE COPY HERE OF WITH YOUR SIGNATURE OF APPROVAL.

PERPARED BY	CHECKED BY	CONFIRMED BY



HYES Optoelectronics, Inc.

2000 Wyatt Drive Suite 6
Santa Clara, CA 95054 USA

CONTENTS:

No.	Item
1	BASIC SPECIFICATION 1.1 Mechanical Specification 1.2 Display Specification 1.3 Outline Dimension 1.4 Block Diagram 1.5 Interface Pin
2	ELECTRICAL CHARACTERISTICS 2.1 Absolute Maximum Ratings 2.2 DC Characteristics 2.2.1 Back-light 2.3 AC Characteristics
3	OPTICAL CHARACTERISTICS 3.1 Condition 3.2 Definition of Optical Characteristics
4	RELIABILITY
5	HANDING PRECAUTION
6	DATECODE
7	PACKING & LOTNO
8	INSPECTION STANDARD

Date : Feb. 26, 2007

TECHNICAL SPECIFICATION

HYES

LCM

HS1501L

Page 2 of 20

1. BASIC SPECIFICATION

1.1 Mechanical specifications

Items	Nominal Dimension	Unit
Dot Matrix	128 x RGB x 128	dots
Module Size (W x H x T)	32.8 x 49.94 x 1.5	mm.
Viewing Area (W x H)	28.31 x 30.17	mm.
Active Area (W x H)	26.1 x 28.15	mm.
Dot Size (W x H)	0.192 x 0.21	mm.
Dot Pitch (W x H)	0.204 x 0.22	mm.
Driving method	1/128	Duty
	1/10	Bias
Driving IC Package	COG	

* Expose the driver IC under blaze (luminosity over than 1 cd) when using the LCM may cause IC operating failure.

1.2 Display specification

Display	Descriptions	Note
LCD Type	Color STN	
LCD Mode	Negative	
Polarizer Mode	Transmissive	
Polarizer UV-Cutting	With	
Polarizer Surface	Normal	
Background Color	Black	
Backlight Type	-	
Backlight Color	-	
Viewing Direction	6 O'clock Direction	

* Color tone is slightly changed by temperature and driving voltage.

1.3 Outline dimension

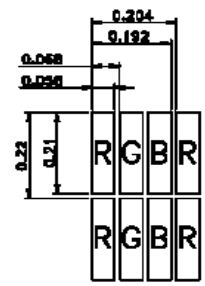
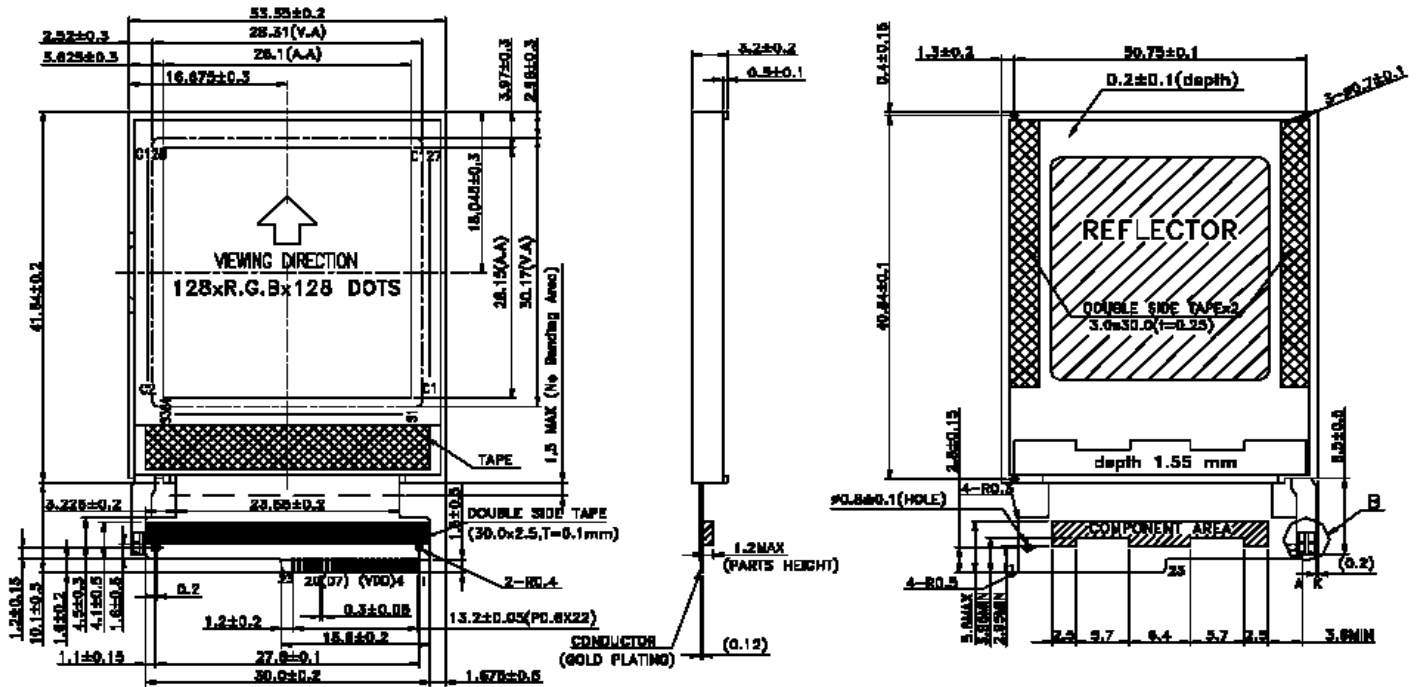

DOTS DETAIL

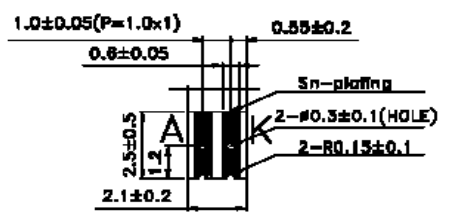

DETAIL B

- NOTE:**
- 1.LCD:COLOR STN MODE, TRANSMISSIVE TYPE, NEGATIVE
 - 2.VIEWING DIRECTION: 6 O'CLOCK
 - 3.TOP: -20° C~70° C ; TST: -30° C~80° C
 - 4.LED COLOR: WHITE; 2 PCS DICE ; VLED=5.0V IF : 20mA ± 5mA
 - 5.DRIVER IC: UC1697

Date : Feb. 26, 2007

TECHNICAL SPECIFICATION



LCM

HS1501L

Page 3 of 20

1.4 Block diagram:

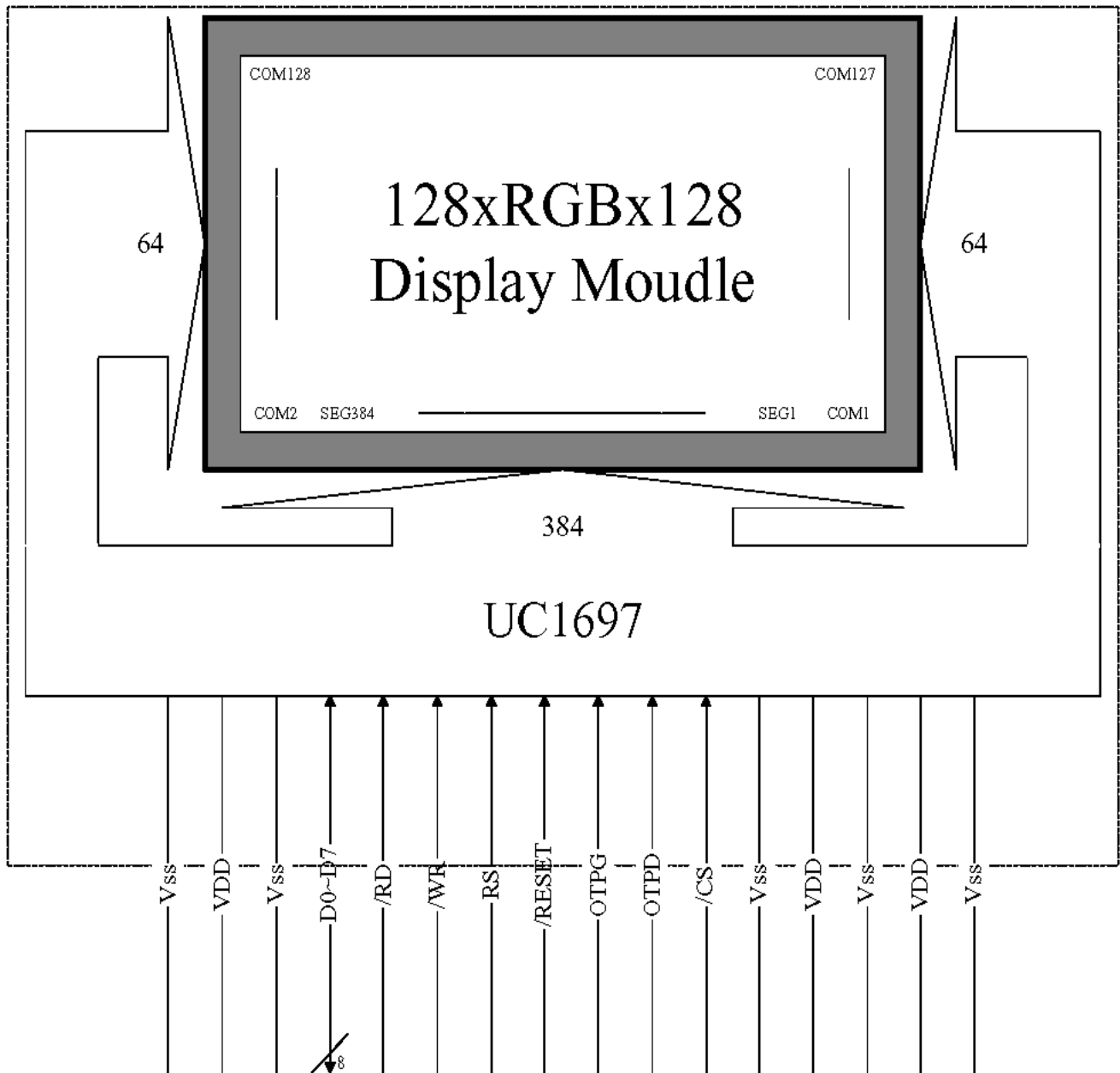

Date : Feb. 26, 2007

TECHNICAL SPECIFICATION

HYES

LCM

HS1501L

Page 5 of 20

1.5 Interface pin :

Pin No.	Pin Symbol	I/O	Description
1	V _{SS}	P	Ground pin for the circuit system.
2	VDD	P	Power supply input pin for the circuit system.(+2.8V)
3	V _{SS}	P	Ground pin for the circuit system.
4	VDD	P	Power supply input pin for the circuit system.(+2.8V)
5	V _{SS}	P	Ground pin for the circuit system.
6	/CS	I	Chip Select. Chip is selected when /CS = L When the chip is not selected, D[7:0] will be high impedance.
7	OTPD	I	This is used as one of the high voltage power supply for MTP programming operation.
8	OTPG	I	
9	/RESET	I	When /RESET=L, all control registers are re-initialized by their default states. When /RESET is not used, connect the pin to VDD.
10	RS	I	Select Control data or Display data for read/write operation. L: Control data H: Display data
11	/WR	I	The /WR is a data write signal. The data on D7~D0 are latched at rising edge of the /WR signal.
12	/RD	I	The /RD is a data read signal. When RDE is "L", D7~D0 are in an output status.
13~20	D0~D7	I/O	Bi-directional bus for parallel host interfaces. Always connect unused pins to either VSS or VDD.
21	V _{SS}	P	Ground pin for the circuit system.
22	VDD	P	Power supply input pin for the circuit system.(+2.8V)
23	V _{SS}	P	Ground pin for the circuit system.

2. ELECTRICAL CHARACTERISTICS

2.1 Absolute Maximum Ratings

Items	Symbol	Min.	Max.	Unit
Supply voltage for logics	VDD	-0.3	+4.0	V
Supply voltage for driving LCD	VLCD	-0.3	20	V
Operate temperature range	T _{OP}	-20	70	°C
Storage temperature range	T _{ST}	-30	80	°C

2.2 DC Characteristics

Items	Symbol	Min.	Typ.	Max.	Unit	Condition
Supply voltage (Logic)	VDD	--	2.8	--	V	
Supply voltage (LCD)	VLCD	12.9	13.2	13.5	V	*NOTE1
Input high level voltage	V _{IH}	0.8*VDDIO	--	--	V	
Input low level voltage	V _{IL}	--	--	0.2*VDDIO	V	
Power supply current	I _{DD}	--	--	3.0	mA	*NOTE2

*NOTE1 : Min. and Max. Voltage is mean within the range will has optimum contrast at Ta:25°C Typ. Voltag is specified as module driving condition: Ta=25°C, V_{OP} at Optimum Contrast,the measuring conditi as below, this value is **HYES** recommend when customer change the set condition , the VLCD will be change.

*NOTE2 :

Measuring Condition:

Standard Value MAX.

T_a = 25°C

V_{DD} - V_{SS} = 2.8V

V_{DD} - V_o = V_{OP} at optimum contrast

f_{osc} =

Duty = 1/128 Duty

Display Pattern = Checkered pattern

Vop set instruction description

COMMAND	CODE								DESCRIPTION
	D7	D6	D5	D4	D3	D2	D1	D0	
Set LCD Bias Ratio	111010##								Bias ratio definition: 11101001=1/10 Bias
Set VBIAS Potentiometer	10000001 #####								Program VBIAS Potentiometer 01101011

2-2-1 Back-light only Specification :

PARAMETER	SYMBOL	MIN	TYP	MAX	Unit	Test Condition	NOTE
Supply Current	I _f	-	20	24	mA	Ta=25°C	-
Supply Voltage	V _s	-	5.0	-	V	Ta=25°C	-
Brightness	Br	2200	2500	-	cd/m ²	Ta=25°C I _f =20mA	-
Half-Life Time	L _f	-	10000	-	hrs	Ta=25°C	1

Note 1 : The “ Half-Life Time ”is defined as the module brightness decrease to 50% original brightness.

Date : Feb. 26, 2007

TECHNICAL SPECIFICATION

HYES

LCM

HS1501L

Page 8 of 20

2.3 AC Characteristics

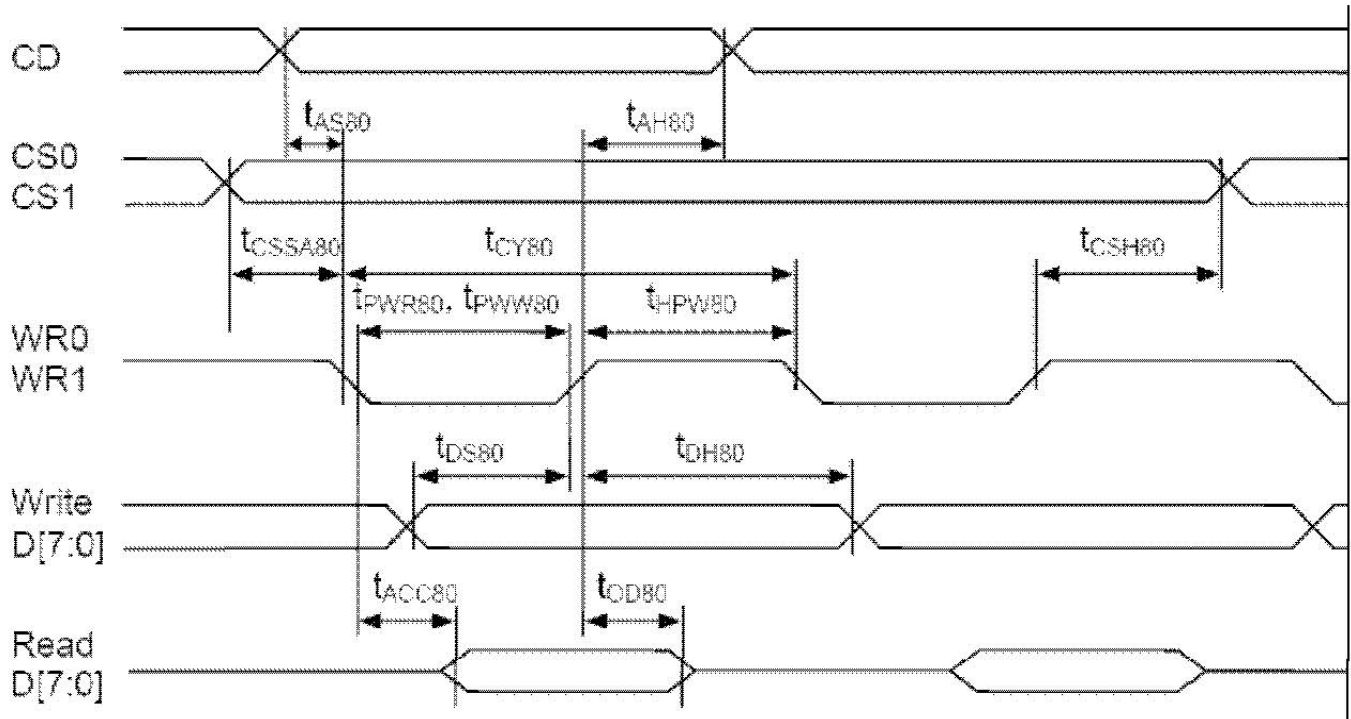

($2.5V \leq V_{DD} < 3.3V$, $T_a = -30$ to $+85^\circ C$):

Symbol	Signal	Description	Condition	Min.	Max.	Units
t_{AS80}	CD	Address setup time		0	-	nS
t_{AH80}		Address hold time		0	-	nS
t_{CY80}		System cycle time		170 130 100 80	-	nS
		16-bit (read) (write) 8-bit (read) (write)				
t_{PWR80}	WR1	Pulse width		70 30	-	nS
		16-bit (read) 8-bit				
t_{PWW80}	WR0	Pulse width		70 30	-	nS
		16-bit (write) 8-bit				
t_{HPW80}	WR0, WR1	High pulse width		100 60 70 50	-	nS
		16-bit (read) (write) 8-bit (read) (write)				
t_{DS80}	D0~D15	Data setup time		30	-	nS
t_{DH80}		Data hold time		0	-	nS
t_{ACC80}		Read access time	$C_L = 100pF$	-	60	nS
t_{OD80}		Output disable time		15	30	nS
t_{CSSA80}	CS1/CS0	Chip select setup time		0	-	nS
t_{CSH80}		Chip select hold time		0	-	nS

Note: 8-bit bus timing is only for 5-6-5 color input mode.

Date : Feb. 26, 2007

TECHNICAL SPECIFICATION

HYES

LCM

HS1501L

Page 9 of 20

3. OPTICAL CHARACTERISTICS

3.1 Characteristics

Driving condition

Item	Duty	Bias	Note
Value	1/128	1/10	1

Electrical and Optical Characteristics

No.	Item	symbol / temp.	Min.	Typ.	Max.	Unit	Note	
1	Response Time	Tr	25 °C	-	160	320	ms	2
		Tf	25 °C	-	55	110		
2	Viewing Angle	Front-Rear	$\Phi = 270^\circ$	-10	-	30	degree	3
		Left-Right		-30	-	30		
3	Contrast Ratio	Cr	25 °C	-	25	-	-	4
4	Red x-code	Rx	25 °C	0.50	0.55	0.60	-	5
	Red y-code	Ry		0.27	0.32	0.37		
	Green x-code	Gx		0.25	0.30	0.35		
	Green y-code	Gy		0.49	0.54	0.59		
	Blue x-code	Bx		0.10	0.15	0.20		
	Blue y-code	By		0.08	0.13	0.18		
	White x-code	Wx		0.25	0.30	0.35		
	White y-code	Wy		0.29	0.34	0.39		

Base on B/L $x = 0.32$

$y = 0.32$

Date : Feb. 26, 2007

TECHNICAL SPECIFICATION

HYES

LCM

HS1501L

Page 10 of 20

3.2 Definition of optical characteristics

Measurement condition :

Transmissive and Transflective type

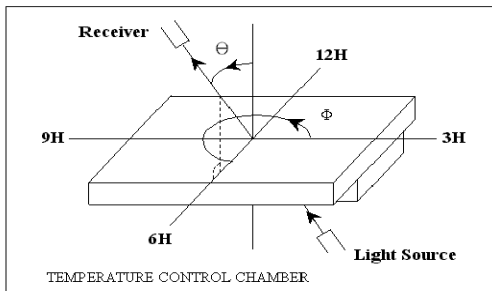

[Note 1] Definition of LCD Driving Vop and Waveform :

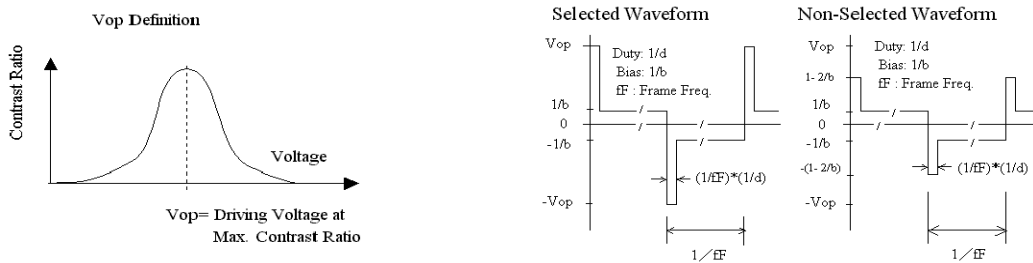

[Note 2] Definition of Response Time

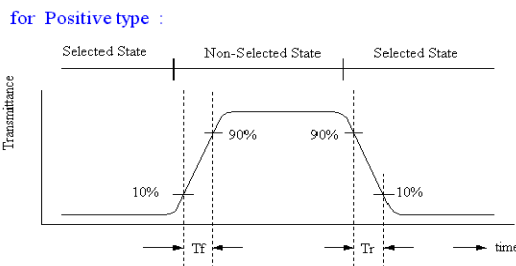

[Note 3] Definition of Viewing Angle :

[Note 4] Definition of Contrast Ratio :

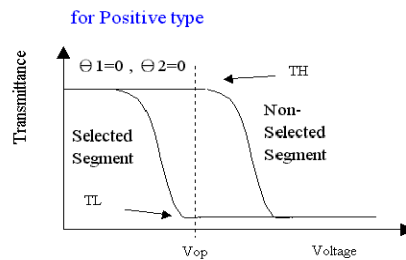
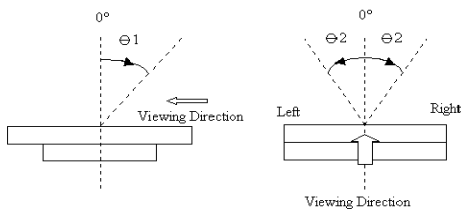

$$\text{Contrast Ratio} = \frac{TH}{TL}$$

Date : Feb. 26, 2007

TECHNICAL SPECIFICATION

HYES

LCM

HS1501L

Page 11 of 20

[Note 5] Definition of measurement of Color Chromaticity and Brightness

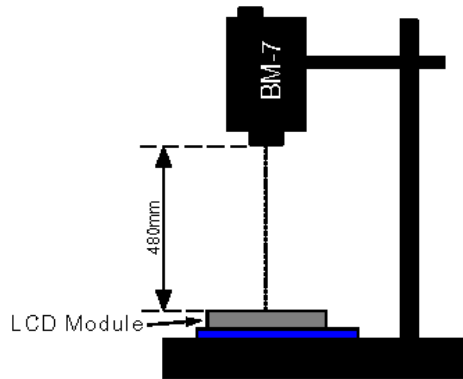

[Note 6] Definition of Brightness Uniformity

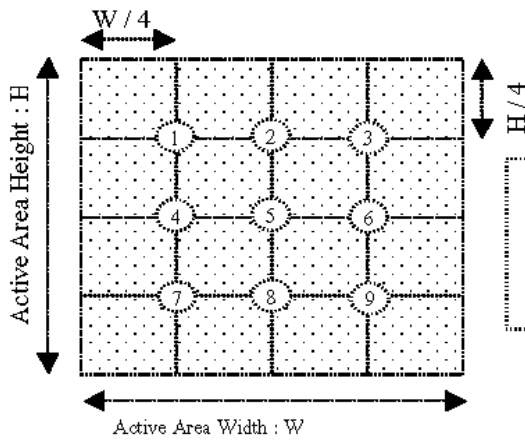

$$\text{Brightness Uniformity} = \frac{\text{Minimum Brightness of Point 1~9}}{\text{Maximum Brightness of Point 1~9}}$$

[Note 7] Definition of Measurement of Reflectance

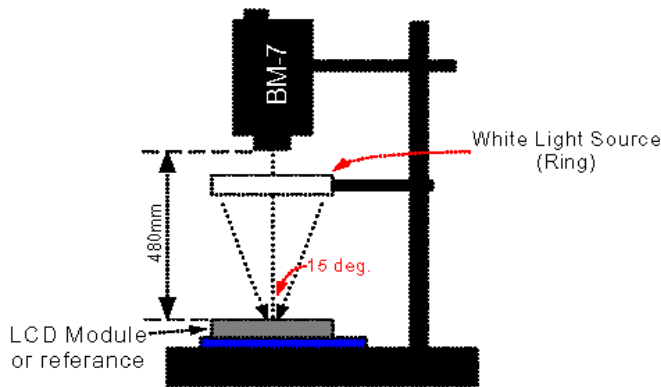

4. RELIABILITY :

Item No	Items	Condition	Remark
1	High temperature operating	70 °C , 200 hours	Finish product (With polarizer)
2	Low temperature operating	-20 °C , 200 hours	Finish product (With polarizer)
3	High temperature storage	80 °C , 200 hours	Finish product (With polarizer)
4	Low temperature storage	-30 °C , 200 hours	Finish product (With polarizer)
5	High temperature & humidity storage	60°C, 90%RH, 100 hours	Finish product (With polarizer)
6	Thermal Shock storage	-30°C , 30min.<=> 80°C , 30min. 10 Cycles	Finish product (With polarizer)
7	Vibration test	10 => 55 =>10 => 55 => 10 Hz , within 1 minute Amplitude : 1.5mm. 15 minutes for each Direction (X,Y,Z)	Finish product (With polarizer)
8	Drop test	Packed, 100CM free fall, 6 sides, 1 corner, 3edges	Finish product (With polarizer)
9	Life time	50,000 hours 25°C , 70%RH below , specification condition driving	Finish product (With polarizer)

- * One single product test for only one item.
- * Judgment after test : keep in room temperature for more than 2 hours.
 - Current consumption < 2 times of initial value
 - Contrast > 1/2 initial value
 - Function : work normally

Date : Feb. 26, 2007

TECHNICAL SPECIFICATION

HYES

LCM

HS1501L

Page 13 of 20

5. PRODUCT HANDING AND APPLICATION

PRECAUTION FOR HANDLING LCM

- The LCD module contains a C-MOS LSI. To avoid damage tom the LSI from static electricity generated while working,Ground your body, work/assembly areas and assembly equipment to protect the module against STATIC ELECTRICITY.
- Do not input any signal before power is turned on.
- Do not take LCM from it's packaging bag unit it is assembled.
- Peel off take LCM protective film slowly since static electricity may be generated.
- Pay attention to the humidity of the work shop, 50~60%RH is satisfactory.
- Use a non-leak iron for soldering LCM.
- Do not touch the display surface or connection terminals area with bare hands.Smudges on the display surface reduce the insulation between terminals.
- Cautions for soldering to LCM:
Condition for soldering I/O terminals:
Temperature at iron tip :280°C±10°C.
Soldering time : 3~4sec./ terminals.
Type of solder : Eutectic solder(rosin flux filled).

PRECAUTION IN USE OF LCD

- Do not contact or scratch the front surface and the contact pads of ac LCD panel with hard materials such as metal or glass or with one's nail.
- To clean the surface , wipe it gently with soft cloth dampened alcohol.
- Do not attempt to wiped off the contact pads.
- Keep LCD panels away from direct sunlight , also avoid them in high-temperature & high humidity environment for a long period.
- Do not drive LCD panels by DC voltage.
- Do not expose LCD panels to organic solvent.
- Liquid in LCD is hazardous substance , any contacts with liquid crystal materials , wash it off immediately with soap and water.
- The polarizer is easily damaged and should be handle with special care. Don't press or rub it with hard objects.

PRECAUTION FOR STORING LCM

- To avoid degradation of the device , do not store the module under the conditions of direct sunlight , high temperature or high humidity . Keep the module in bags designed to prevent static electricity charging under low temperature / normal humidity conditions(avoid high temperature / high humidity and low temperature below 0°C)

USING ON MEDICAL CARE , SAFETY OR HAZARDOUS APPLICATION OR SYSTEM

- An authorization from HYES is required for medical care, safety and hazardous product, application or system . HYES will not be responsible of any damage or loss which caused by this products without any authorization given by HYES .
- This products is not designed for military appliction.

Date : Feb. 26, 2007

TECHNICAL SPECIFICATION

HYES

LCM

HS1501L

Page 14 of 20

6. DATE CODE OF PRODUCTS

- Date code will be shown on each product :

- **Y MM DD - XXX**

Year Month Day - Production lots

- Example: 2 1 2 2 3 - 0 0 3 ==>Year 2002, Dec.,23rd , Batch no.03

7. PACKING

Instruction of lot number:

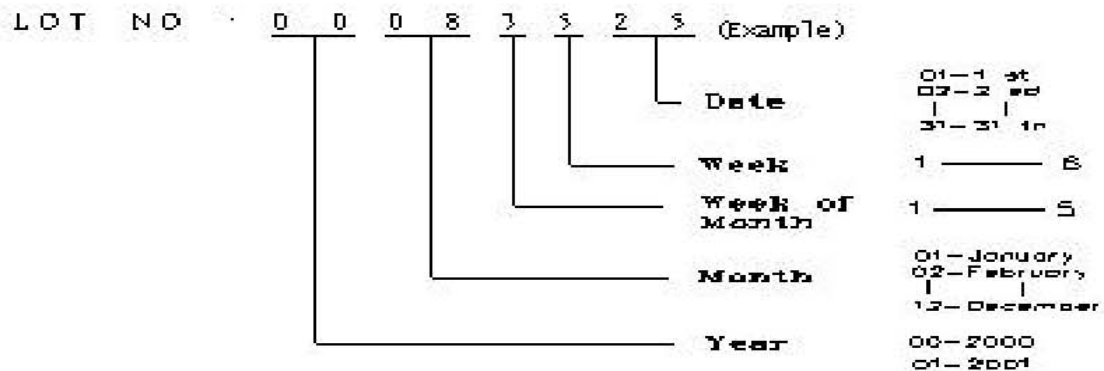

Label of carton:

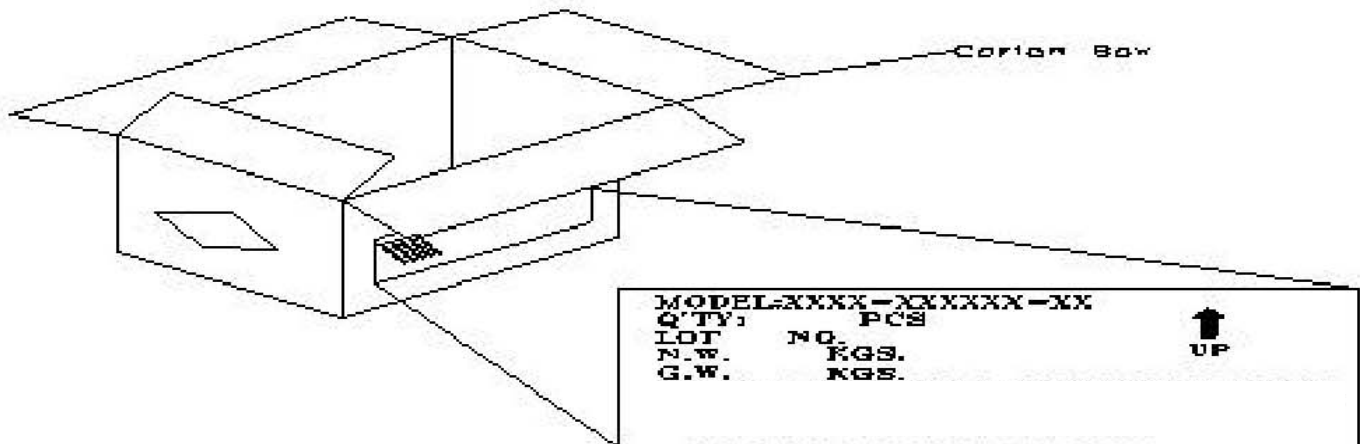

Packing tray must be stacked with alternated direction to each others.
To tacks packing trays in same direction will cause product damaged.

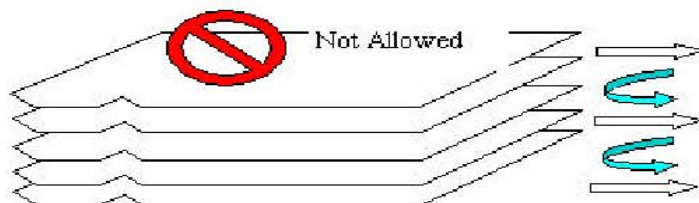
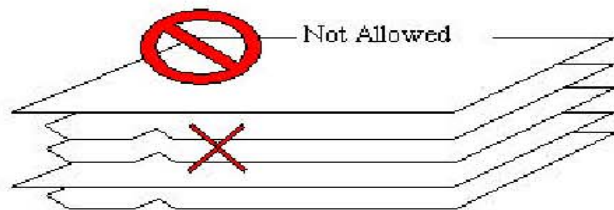

Date : Feb. 26, 2007

TECHNICAL SPECIFICATION

HYES

LCM

HS1501L

Page 16 of 20

8. INSPECTION STANDARD

8.1. QUALITY :

THE QUALITY OF GOODS SUPPLIED TO PURCHASER SHALL COME UP TO THE FOLLOWING STANDARD.

8.1.1. THE METHOD OF PRESERVING GOODS

AFTER DELIVERY OF GOODS FROM **HYES** TO PURCHASER. PURCHASER SHALL CONTROL THE LCM AT -10 °C ~ 40 °C ,AND IT MIGHT BE DESIRABLE TO KEEP AT THE NORMAL ROOM TEMPERATURE AND HUMIDITY UNTIL INCOMING INSPECTION OR THROWING INTO PROCESS LINE.

8.1.2. INCOMING INSPECTION

(A) THE METHOD OF INSPECTION

IF PURCHASER MAKE AN INCOMING INSPECTION , A SAMPLING PLAN SHALL BE APPLIED ON THE CONDITION THAT QUALITY OF ONE DELIVERY SHALL BE REGARDED AS ONE LOT.

(B) THE STANDARD OF QUALITY

ISO-2859-1 (or MIL-STD-105D) , LEVEL II SINGLE PLAN.

CLASS	AQL(%)
CRITICAL	0.4 %
MAJOR	0.65 %
MINOR	1.5 %
TOTAL	1.5 %

EVERY ITEM SHALL BE INSPECTED ACCORDING TO THE CLASS.

(C) MEASURE

IF AS THE RESULT OF ABOVE RECEIVING INSPECTION , A LOT OUT IS DISCOVERED. PURCHASER SHALL BE INFORM SELLER OF IT WITHIN SEVEN DAYS. BUT FIRST SHIPMENT WITHIN FOURTEEN DAYS.

8.1.3. WARRANTY POLICY

HYES WILL PROVIDE ONE-YEAR WARRANTY FOR THE PRODUCTS ONLY IF UNDER SPECIFICATION OPERATING CONDITIONS. **HYES** WILL REPLACE NEW PRODUCTS FOR THESE DEFECT PRODUCTS WHICH UNDER WARRANTY PERIOD AND BELONG TO THE RESPONSIBILITY OF **HYES**.

8.2. CHECKING CONDITION

8.2.1. CHECKING DIRECTION SHALL BE IN THE 45 DEGREE AREA TO FACE THE SAMPLE.

8.2.2. CHECKER SHALL SEE OVER 30 cm. WITH BARE EYES FAR FROM SAMPLE AND USING 2 PCS. OF 20W FLUORESCENT LAMP.

Date : Feb. 26, 2007

TECHNICAL SPECIFICATION

HYES

LCM

HS1501L

Page 17 of 20

8.3. INSPECTION PLAN :

CLASS	ITEM	JUDGEMENT	CLASS
PACKING & INDICATE	1. OUTSIDE AND INSIDE PACKAGE	"MODEL NO." , "LOT NO." AND "QUANTITY" SHOULD INDICATE ON THE PACKAGE.	Minor
	2. MODEL MIXED AND QUANTITY	OTHER MODEL MIXED.....REJECTED QUANTITY SHORT OR OVER.....REJECTED	Critical
	3. PRODUCT INDICATION	"MODEL NO." SHOULD INDICATE ON THE PRODUCT	Major
ASSEMBLY	4. DIMENSION, LCD GLASS SCRATCH AND SCRIBE DEFECT.	ACCORDING TO SPECIFICATION OR DRAWING.	Major
APPEARANCE	5. VIEWING AREA	POLARIZER EDGE OR LCD'S SEALING LINE IS VISABLE IN THE VIEWING AREAREJECTED	Minor
	6. BLEMISH , BLACK SPOT , WHITE SPOT IN THE LCD AND LCD GLASS CRACKS	ACCORDING TO STANDARD OF VISUAL INSPECTION (INSIDE VIEWING AREA)	Minor
	7. BLEMISH , BLACK SPOT WHITE SPOT AND SCRATCH ON THE POLARIZER	ACCORDING TO STANDARD OF VISUAL INSPECTION (INSIDE VIEWING AREA)	Minor
	8. BUBBLE IN POLARIZER	ACCORDING TO STANDARD OF VISUAL INSPECTION (INSIDE VIEWING AREA)	Minor
	9. LCD'S RAINBOW COLOR	STRONG DEVIATION COLOR (OR NEWTON RING) OF LCD.....REJECTED. OR ACCORDING TO LIMITED SAMPLE (IF NEEDED, AND INSIDE VIEWING AREA)	Minor
ELECTRICAL	10. ELECTRICAL AND OPTICAL CHARACTERISTICS (CONTRAST , VOP , CHROMATICITY ... ETC)	ACCORDING TO SPECIFICATION OR DRAWING . (INSIDE VIEWING AREA)	Critical
	11. MISSING PATTERN	MISSING DOT , LINE , CHARACTERREJECTED	Critical
	12. SHORT CIRCUIT , WRONG PATTERN DISPLAY	NON DISPLAY , WRONG PATTERN DISPLAY , CURRENT CONSUMPTION OUT OF SPECIFICATION..... REJECTED	Critical
	13. PIN HOLE , PATTERN DEFORMITY	ACCORDING TO STANDARD OF VISUAL INSPECTION	Minor

Date : Feb. 26, 2007

TECHNICAL SPECIFICATION

HYES

LCM

HS1501L

Page 18 of 20

8.4. STANDARD OF VISUAL INSPECTION

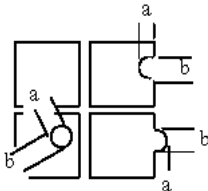
NO.	CLASS	ITEM	JUDGEMENT															
8.4.1	MINOR	· BLEMISH · BLACK SPOT · WHITE SPOT IN THE LCD.	(A) ROUND TYPE: unit : mm. <table border="1"> <thead> <tr> <th>DIAMETER (mm.)</th> <th>ACCEPTABLE Q'TY</th> </tr> </thead> <tbody> <tr> <td>$\Phi \leq 0.1$</td> <td>DISREGARD</td> </tr> <tr> <td>$0.1 < \Phi \leq 0.2$</td> <td>2</td> </tr> <tr> <td>$0.2 < \Phi \leq 0.25$</td> <td>1</td> </tr> <tr> <td>$0.25 < \Phi$</td> <td>0</td> </tr> </tbody> </table> NOTE: $\Phi = (\text{LENGTH} + \text{WIDTH})/2$	DIAMETER (mm.)	ACCEPTABLE Q'TY	$\Phi \leq 0.1$	DISREGARD	$0.1 < \Phi \leq 0.2$	2	$0.2 < \Phi \leq 0.25$	1	$0.25 < \Phi$	0					
		DIAMETER (mm.)	ACCEPTABLE Q'TY															
$\Phi \leq 0.1$	DISREGARD																	
$0.1 < \Phi \leq 0.2$	2																	
$0.2 < \Phi \leq 0.25$	1																	
$0.25 < \Phi$	0																	
		· BLEMISH · BLACK SPOT · WHITE SPOT AND SCRATCH ON THE POLARIZER	(B) LINER TYPE: unit : mm. <table border="1"> <thead> <tr> <th>LENGTH</th> <th>WIDTH</th> <th>ACCEPTABLE Q'TY</th> </tr> </thead> <tbody> <tr> <td>-----</td> <td>$W \leq 0.03$</td> <td>DISREGARD</td> </tr> <tr> <td>$L \leq 5.0$</td> <td>$0.03 < W \leq 0.05$</td> <td>3</td> </tr> <tr> <td>$L \leq 5.0$</td> <td>$0.05 < W \leq 0.07$</td> <td>1</td> </tr> <tr> <td>-----</td> <td>$0.07 < W$</td> <td>FOLLOW ROUND TYPE</td> </tr> </tbody> </table>	LENGTH	WIDTH	ACCEPTABLE Q'TY	-----	$W \leq 0.03$	DISREGARD	$L \leq 5.0$	$0.03 < W \leq 0.05$	3	$L \leq 5.0$	$0.05 < W \leq 0.07$	1	-----	$0.07 < W$	FOLLOW ROUND TYPE
LENGTH	WIDTH	ACCEPTABLE Q'TY																
-----	$W \leq 0.03$	DISREGARD																
$L \leq 5.0$	$0.03 < W \leq 0.05$	3																
$L \leq 5.0$	$0.05 < W \leq 0.07$	1																
-----	$0.07 < W$	FOLLOW ROUND TYPE																
8.4.2	MINOR	BUBBLE IN POLARIZER	unit : mm. <table border="1"> <thead> <tr> <th>DIAMETER</th> <th>ACCEPTABLE Q'TY</th> </tr> </thead> <tbody> <tr> <td>$\Phi \leq 0.15$</td> <td>DISREGARD</td> </tr> <tr> <td>$0.15 < \Phi \leq 0.5$</td> <td>2</td> </tr> <tr> <td>$0.5 < \Phi$</td> <td>0</td> </tr> </tbody> </table>	DIAMETER	ACCEPTABLE Q'TY	$\Phi \leq 0.15$	DISREGARD	$0.15 < \Phi \leq 0.5$	2	$0.5 < \Phi$	0							
DIAMETER	ACCEPTABLE Q'TY																	
$\Phi \leq 0.15$	DISREGARD																	
$0.15 < \Phi \leq 0.5$	2																	
$0.5 < \Phi$	0																	
8.4.3	MINOR	PIN HOLE · PATTERN DEFORMITY	<div style="display: flex; align-items: center;">  <table border="1" style="margin-left: 20px;"> <thead> <tr> <th colspan="2">DIAMETER</th> <th>ACC. Q'TY</th> </tr> </thead> <tbody> <tr> <td>$\Phi \leq 0.1$</td> <td></td> <td>DISREGARD</td> </tr> <tr> <td>$0.1 < \Phi \leq 0.25$</td> <td></td> <td>3</td> </tr> <tr> <td>$0.25 < \Phi$</td> <td></td> <td>0</td> </tr> </tbody> </table> </div> <p style="text-align: center;">$\Phi = (a+b)/2$</p>	DIAMETER		ACC. Q'TY	$\Phi \leq 0.1$		DISREGARD	$0.1 < \Phi \leq 0.25$		3	$0.25 < \Phi$		0			
DIAMETER		ACC. Q'TY																
$\Phi \leq 0.1$		DISREGARD																
$0.1 < \Phi \leq 0.25$		3																
$0.25 < \Phi$		0																

Date : Feb. 26, 2007

TECHNICAL SPECIFICATION

HYES

LCM

HS1501L

Page 19 of 20

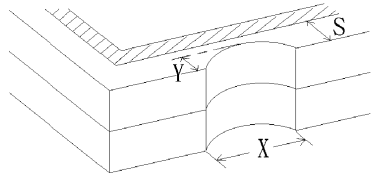
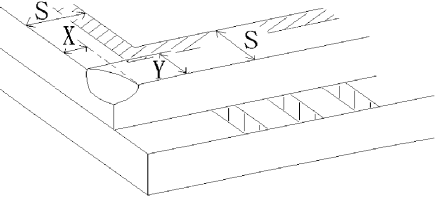
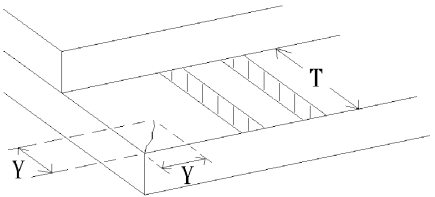
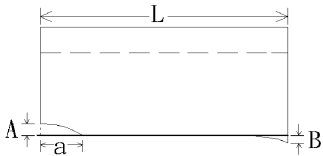
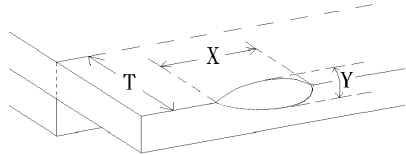
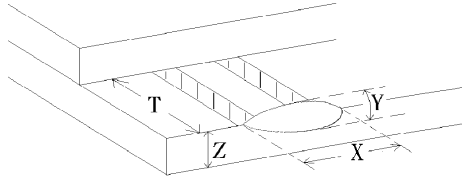
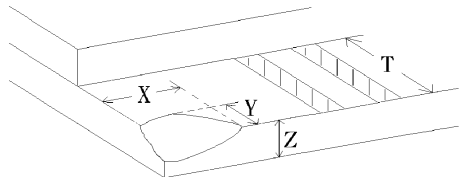
NO.	CLASS	ITEM	JUDGEMENT
8.4.4	MINOR	CHIPPING	 $Y > S$ REJ.
8.4.5	MINOR	CHIPPING	 $X \text{ or } Y > S$ REJ.
8.4.6	MAJOR	GLASS CRACK	 $Y > (1/2) T$ REJ.
8.4.7	MAJOR	SCRIBE DEFECT	 <ol style="list-style-type: none"> $a > L/3$, $A > 1.5\text{mm}$. REJ. B : ACCORDING TO DIMENSION
8.4.8	MINOR	CHIPPING (ON THE TERMINAL AREA)	 $\Phi = (x+y)/2 > 2.5 \text{ mm}$ REJ.
8.4.9	MINOR	CHIPPING (ON THE TERMINAL SURFACE)	 $Y > (1/3) T$ REJ.
8.4.10	MINOR	CHIPPING	 $Y > T$ REJ.

Date : Feb. 26, 2007

TECHNICAL SPECIFICATION

HYES

LCM

HS1501L

Page 20 of 20