

# APPROVAL

PART NO.	DESCRIPTION	REMARKS
HT2501ULH	LCD MODULE (320 x RGB x 240)	* ROHS compliant * Sunlight Readable

CUSTOMER APPLICATION P/N	
APPROVED BY	
DATE	

PLEASE KINDLY FIND AND APPROVE THE SPECIFICATIONS INSERTED  
HEREIN AND RETURN ONE COPY HERE OF WITH YOUR SIGNATURE OF APPROVAL.

PERPARED BY	CHECKED BY	CONFIRMED BY



**HYES Optoelectronics, Inc.**

2000 Wyatt Drive Suite 6  
Santa Clara, CA 95054 USA

## CONTENTS:

No.	Item
1	<b>BASIC SPECIFICATION</b> 1.1 Mechanical Specification 1.2 Display Specification 1.3 Outline Dimension 1.4 Block Diagram 1.5 Interface Pin
2	<b>ELECTRICAL CHARACTERISTICS</b> 2.1 Absolute Maximum Ratings 2.2 DC Characteristics 2.2.1 Back-light 2.3 AC Characteristics 2.4 Interface Timing Chart
3	<b>OPTICAL CHARACTERISTICS</b> 3.1 Condition 3.2 Definition of Optical Characteristics
4	<b>RELIABILITY</b>
5	<b>PRODUCT HANDING AND APPLICATION</b>
6	<b>DATECODE</b>
7	<b>PACKING &amp; LOTNO</b>
8	<b>INSPECTION STANDARD</b>

Date : Nov. 14, 2008

TECHNICAL SPECIFICATION

**HYES**

LCM

HT2501ULH

Page 2 of 25

## 1. BASIC SPECIFICATION

### 1.1 Mechanical specifications

Items	Nominal Dimension	Unit
Active screen size	2.5 diagonal	-
Dot Matrix	320*RGB*240	dots
Module Size (W x H x T)	58.4 X 49.7 X 3.5	mm.
Active Area (W x H)	50.88 x 38.16	mm.
Pixel Size (W x H)	0.159 x 0.159	mm.
Interface	Parallel 18-bit RGB CCIR656&CCIR601	-
Driving IC Package	COG	-
Module weight	15	g

### 1.2 Display specification

Display	Descriptions	Note
LCD Type	a-Si TFT	-
LCD Mode	TN/Normal white	-
Polarizer Mode	Transmissive	-
Polarizer Surface	Normal	
Pixel arrangement	RGB-Delta	
Backlight Type	LED	
Viewing Direction	12 O'clock Direction	-

\* Color tone is slightly changed by temperature and driving voltage.

### 1.3 Outline dimension

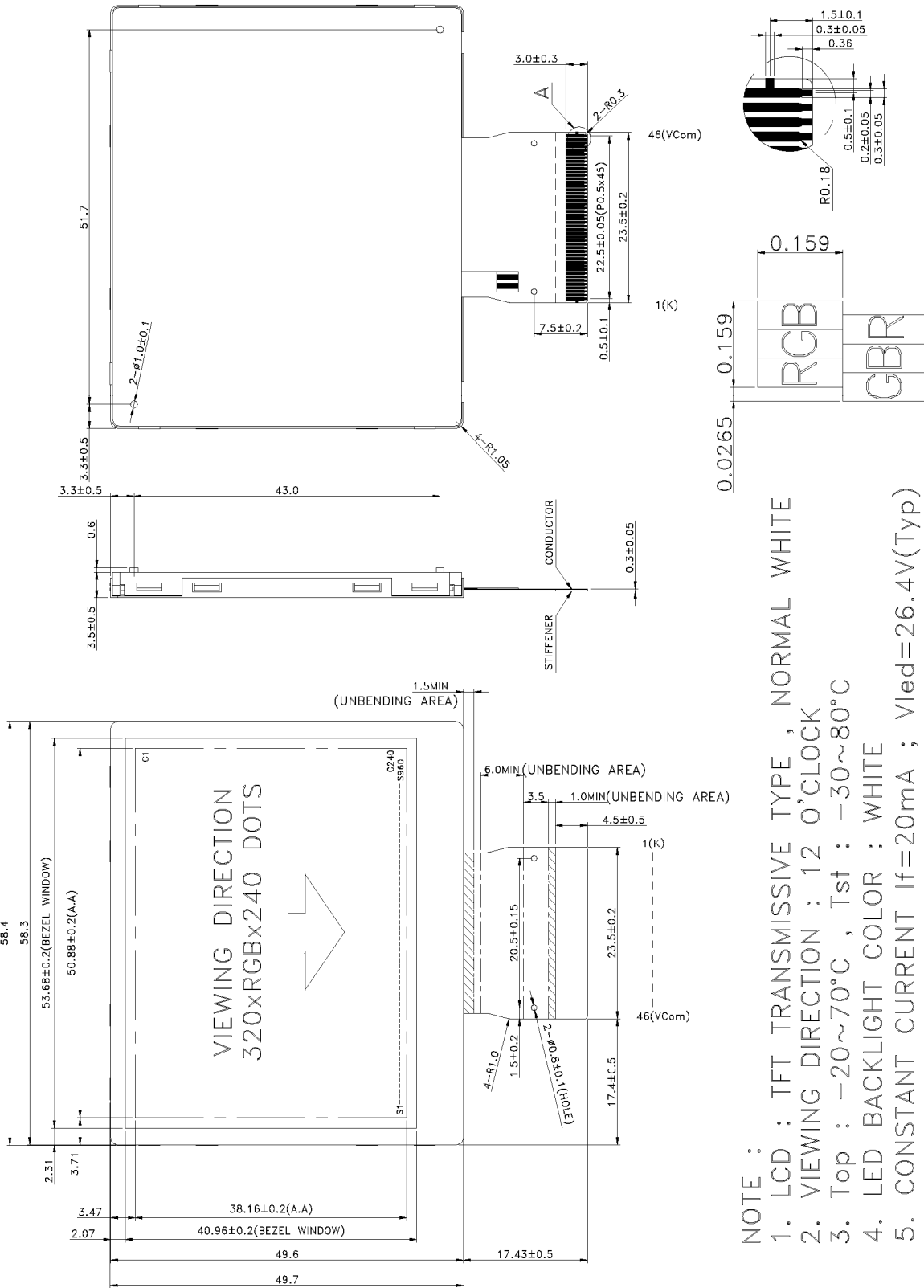

- NOTE :
1. LCD : TFT TRANSMISSIVE TYPE , NORMAL WHITE
  2. VIEWING DIRECTION : 12 O'CLOCK
  3. Top : -20~70°C , Tst : -30~80°C
  4. LED BACKLIGHT COLOR : WHITE
  5. CONSTANT CURRENT If=20mA ; Vled=26.4V(Typ)
  6. RoHS-COMPLIANT
  7. Brightness : 500 cd/m<sup>2</sup> (MIN)
  8. TOLERANCE FOR NOT ASSIGNED : ±0.3mm
  9. THE MINIMUM BENDABLE RADIUS(INNER) OF THE FPC IS 0.5 MM

PIXEL SIZE DETAIL "A"

Date : Nov. 14, 2008

TECHNICAL SPECIFICATION

**HYES**

LCM

HT2501ULH

Page 4 of 25

1.4 Block diagram:

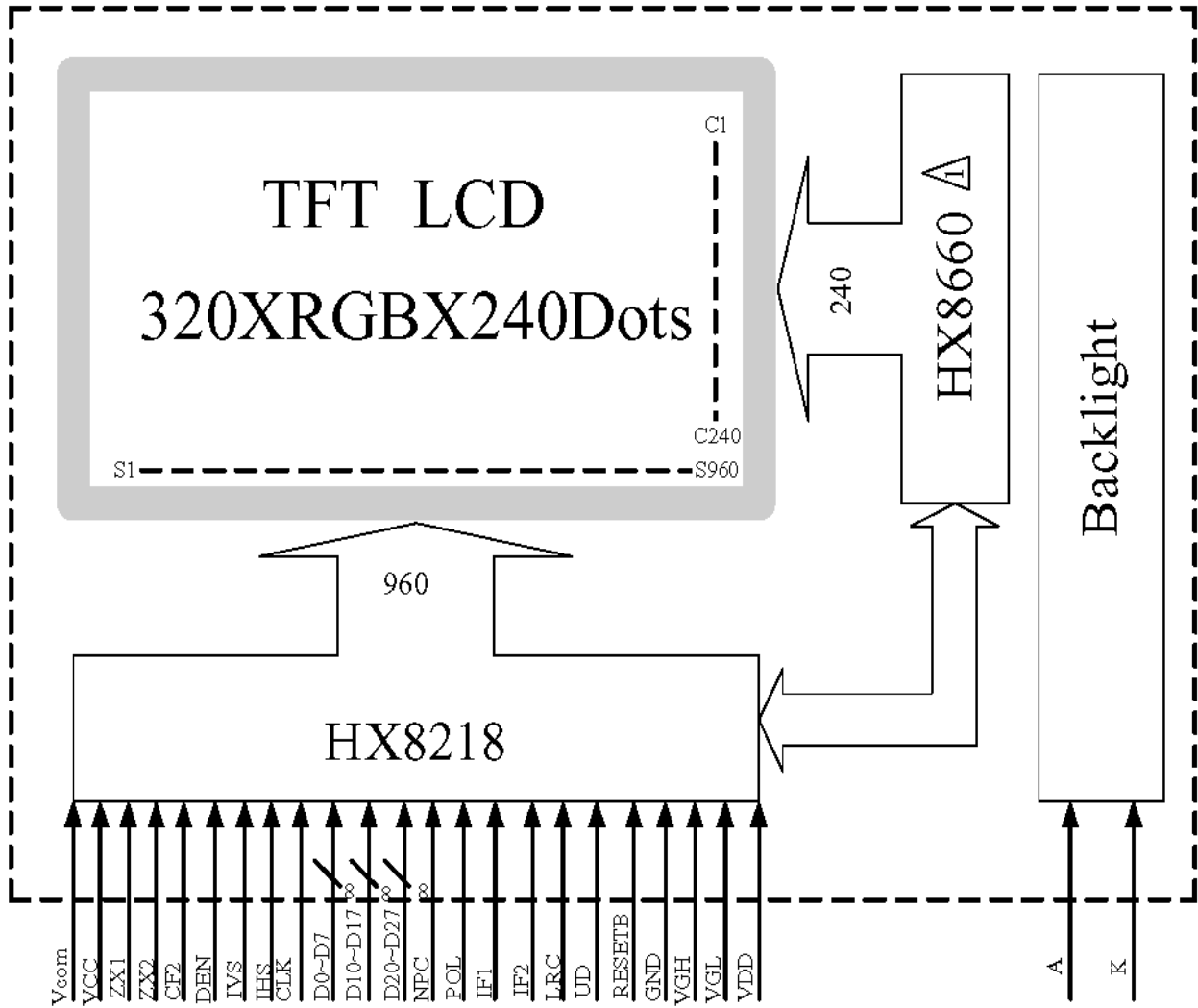

### 1.5 Interface pin :

Pin No.	Pin Symbol	I/O	Description								
1	K	P	Power supply for LED-								
2	A	P	Power supply for LED+								
3	VDD	P	Analog power. 4.5V to 5.5V.								
4	VGL	P	Power supply for LCM drive output Low								
5	VGH	P	Power supply for LCM drive output High								
6	GND	P	Ground								
7	RESETB	I	Hardware global reset. Low active. Normally pull high.								
8	UD	I	Up/down scan setting. When UD=H, reverse scan. When UD=L, normal scan.								
9	LRC	I	The shift direction of device internal shift register is controlled by this pin as shown below: LRC=H: STH→OUT1- - - OUT960→STHO LRC=L: STH→OUT960- - -OUT1→STHO								
10~11	IF2~IF1	I	<table border="1"> <thead> <tr> <th>IF2,IF1</th> <th>Input data format</th> </tr> </thead> <tbody> <tr> <td>L,H</td> <td>Parallel RGB</td> </tr> <tr> <td>H,L</td> <td>CCIR601</td> </tr> <tr> <td>H,H</td> <td>CCIR656</td> </tr> </tbody> </table>	IF2,IF1	Input data format	L,H	Parallel RGB	H,L	CCIR601	H,H	CCIR656
IF2,IF1	Input data format										
L,H	Parallel RGB										
H,L	CCIR601										
H,H	CCIR656										
12	POL	O	Polarity select for the line inversion control signal. When POL=L, output voltage is negative polarity. When POL=H, output voltage is positive polarity.								
13	NPC	O	NTSC or PAL mode auto detection result. When NPC=H, NTSC mode is selected. When NPC=L, PAL mode is selected.								
14~37	D27~D20 D17~D10 D7~D0	I	Digital data input. DX0 is LSB and DX7 is MSB. 1. If parallel RGB input mode is used, D0X, D1X, and D2X indicate R, G, and B data in turn. 2. If CCIR601/656 input mode is selected, only D07~D00 are used, and others short to GND..								

Date : Nov. 14, 2008

TECHNICAL SPECIFICATION

**HYES**

LCM

HT2501ULH

Page 6 of 25

### 1.5 Interface pin :

Pin No.	Pin Symbol	I/O	Description
38	CLK	I	Clock signal. Latching data at the rising edge.
39	IHS	I	Horizontal sync input in digital RGB mode.
40	IVS	I	Vertical sync input in digital RGB mode.
41	DEN	I	Input data enable control
42	CF2	I	Define the used delta type color filter.
43~44	ZX2~ZX1	I	Zoom in/out modes setting pin. Zoom function is only active in CCIR601/656 input mode
45	VCC	P	Digital power. 3V to 3.6V.
46	Vcom	I	TFT driver signal. Connect to POL through OP.

## 2. ELECTRICAL CHARACTERISTICS

### 2.1 Absolute Maximum Ratings

Items	Symbol	Min.	Max.	Unit
Power supply voltage	VCC	-0.3	5.5	V
Operate temperature range	T <sub>OP</sub>	-20	70	°C
Storage temperature range	T <sub>ST</sub>	-30	80	°C

### 2.2 DC Characteristics

T<sub>a</sub>=25°C

Items	Symbol	Min.	Typ.	Max.	Unit	Condition
Power supply voltage	V <sub>DD</sub>	4.5	5.0	5.5	V	
Power supply voltage	V <sub>CC</sub>	3.0	3.3	3.6	V	
Power supply voltage	V <sub>GH</sub>	--	15	--	V	
Power supply voltage	V <sub>GL</sub>	--	-10	--	V	
Input Voltage	V <sub>L</sub>	0	--	0.3 V <sub>CC</sub>	V	L level
	V <sub>H</sub>	0.7 V <sub>CC</sub>	--	V <sub>CC</sub>	V	H level
Current for Driver	I <sub>CC</sub>	--	--	10.0	mA	V <sub>CC</sub> =3.3V

#### 2-2.1 Back-light Characteristics

PARAMETER	SYMBOL	MIN	TYP	MAX	Unit	Test Condition	NOTE
Supply Current	I <sub>f</sub>	-	20	-	mA	T <sub>a</sub> =25°C	-
Supply Voltage	V <sub>F</sub>	-	26.4	--	V	T <sub>a</sub> =25°C	-
Brightness	Br	500	--	--	cd/m <sup>2</sup>	T <sub>a</sub> =25°C I <sub>f</sub> =20mA	8
Half-Life Time	L <sub>f</sub>	-	10000	-	hrs	T <sub>a</sub> =25°C±2°C 60±10% RH	9

Note 8 : Back-light only.

Note 9 : The “ Half-Life Time ”is defined as the module brightness decrease to 50% original brightness.

Date : Nov. 14, 2008

TECHNICAL SPECIFICATION

**HYES**

LCM

HT2501ULH

Page 8 of 25



## 2.3 AC Characteristics

### Digital Parallel RGB interface (960x240 resolution)

PARAMETER		Symbol	Min.	Typ.	Max.	Unit
CLK period		$T_{OSC}$	-	156	-	ns
Data setup time		$T_{SU}$	12	-	-	ns
Data hold time		$T_{HD}$	12	-	-	ns
IHS period		$T_H$	-	408	-	$T_{OSC}$
IHS pulse width		$T_{HS}$	5	30	-	$T_{OSC}$
IHS setup time		$T_{Cr}$	12	-	-	ns
IHS hold time		$T_{Cf}$	12	-	-	ns
IVS pulse width		$T_{VS}$	1	3	5	$T_H$
IVS setup time		$T_{Vr}$	12	-	-	ns
IVS hold time		$T_{Vf}$	12	-	-	$\mu s$
IVS-DEN time	NTSC	$T_{VSE}$	-	18	-	$T_H$
	PAL	$T_{VSE}$	-	26	-	$T_H$
IHS-DEN time		$T_{HE}$	36	68	88	$T_{OSC}$
DEN pulse width		$T_{EP}$	-	320	-	$T_{OSC}$
DEN-STH time		$T_{DES}$	-	1	-	$T_{OSC}$
IVS period	NTSC	-	-	262.5	-	$T_H$
	PAL	-	-	312.5	-	$T_H$

Note: When SYNC mode is used, 1st data start from 68th CLK after IHS falling.

### CCIR601/656 Interface

PARAMETER	Symbol	Min.	Typ.	Max.	Unit
CLK period	$T_{OSC}$	-	37	-	ns
Data setup time	$T_{SU}$	12	-	-	ns
Data hold time	$T_{HD}$	12	-	-	ns
IVS falling to IHS rising time for odd field	$T_{HVO}$	1	-	-	$T_{OSC}$
IVS falling to IHS falling time for even field	$T_{HVE}$	1	-	-	$T_{OSC}$

Date : Nov. 14, 2008

TECHNICAL SPECIFICATION

**HYES**

LCM

HT2501ULH

Page 9 of 25

## 2.3 AC Characteristics

### Hardware reset timing

PARAMETER	Symbol	Min.	Typ.	Max.	Unit
RESETB low pulse width	$T_{RSB}$	10	-	-	$\mu s$
STB to Vsync Setup Time	$T_{STB}$	20	-	-	ns

### Output signal characteristics for digital input signal

PARAMETER	Symbol	Min.	Typ.	Max.	Unit	
Rising time	$T_r$	-	-	10	ns	
Falling time	$T_f$	-	-	10	ns	
Internal STH setup time	$T_{SUS}$	12	-	-	ns	
Internal STH hold time	$T_{HDS}$	12	-	-	ns	
Internal data setup time	$T_{SUD}$	60	-	-	ns	
Internal data hold time	$T_{HDD}$	40	-	-	ns	
OEH pulse width	$T_{OEH}$	-	1248	-	ns	
OEV pulse width	$T_{OEV}$	-	4992	-	ns	
CKV pulse width	$T_{CKV}$	-	3744	-	ns	
IHS-OEH time	$T_1$	-	4368	-	ns	
IHS-CKV time	$T_2$	-	2496	-	ns	
IHS-OEV time	$T_3$	-	624	-	ns	
IHS-POL time	$T_4$	-	4368	-	ns	
STV setup time	$T_{SUV}$	-	1872	-	ns	
STV pulse width	$T_{STV}$	-	1	-	$T_H$	
IVS-STV time	NTSC	$T_{VS1}$	-	19	-	$T_H$
	PAL	$T_{VS1}$	-	27	-	$T_H$
OEH-STV time	$T_{OES}$	-	2	-	$T_H$	
Output settling time	$T_{ST}$	-	12	20	$\mu s$	

## 2.4 Interface Timing Chart

### ● Digital Parallel RGB

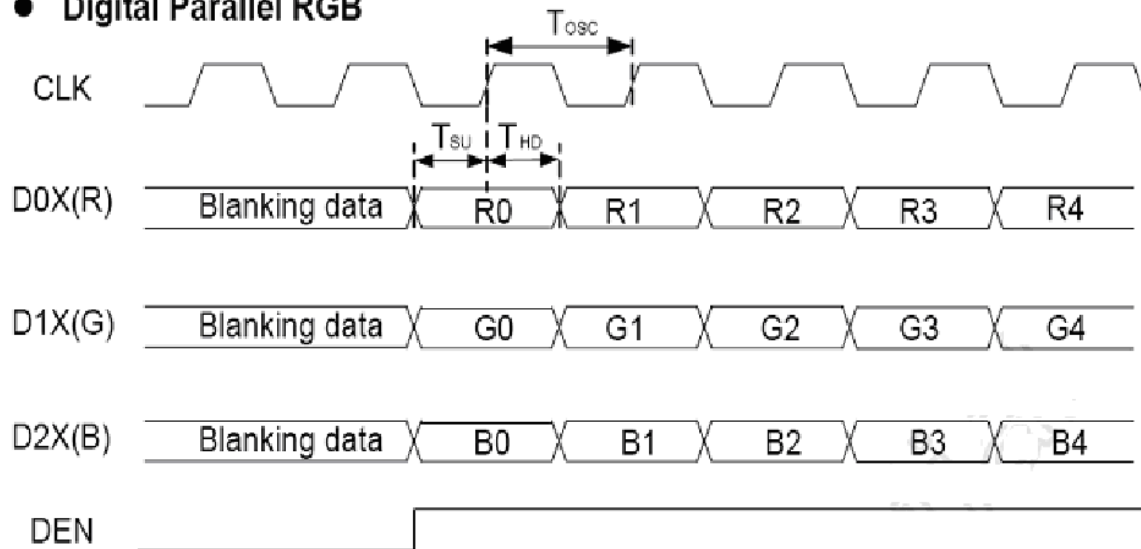

### ● CCIR656

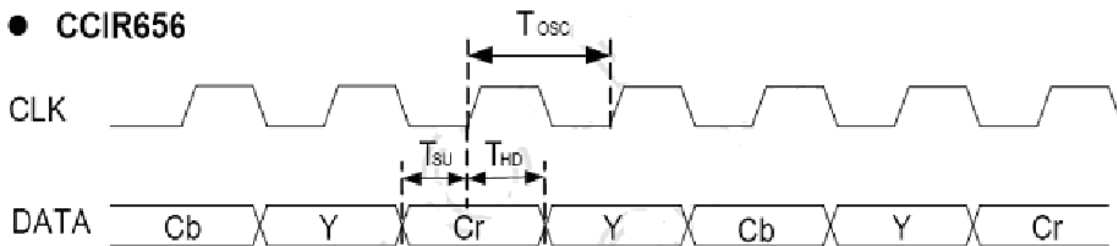

### ● CCIR601 (HS\_POL=L in Register R2)

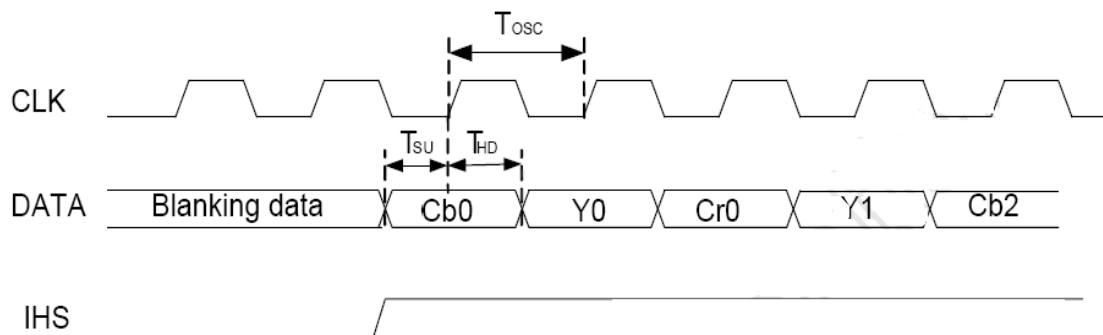

Digital RGB timing waveform  
DE Only Mode

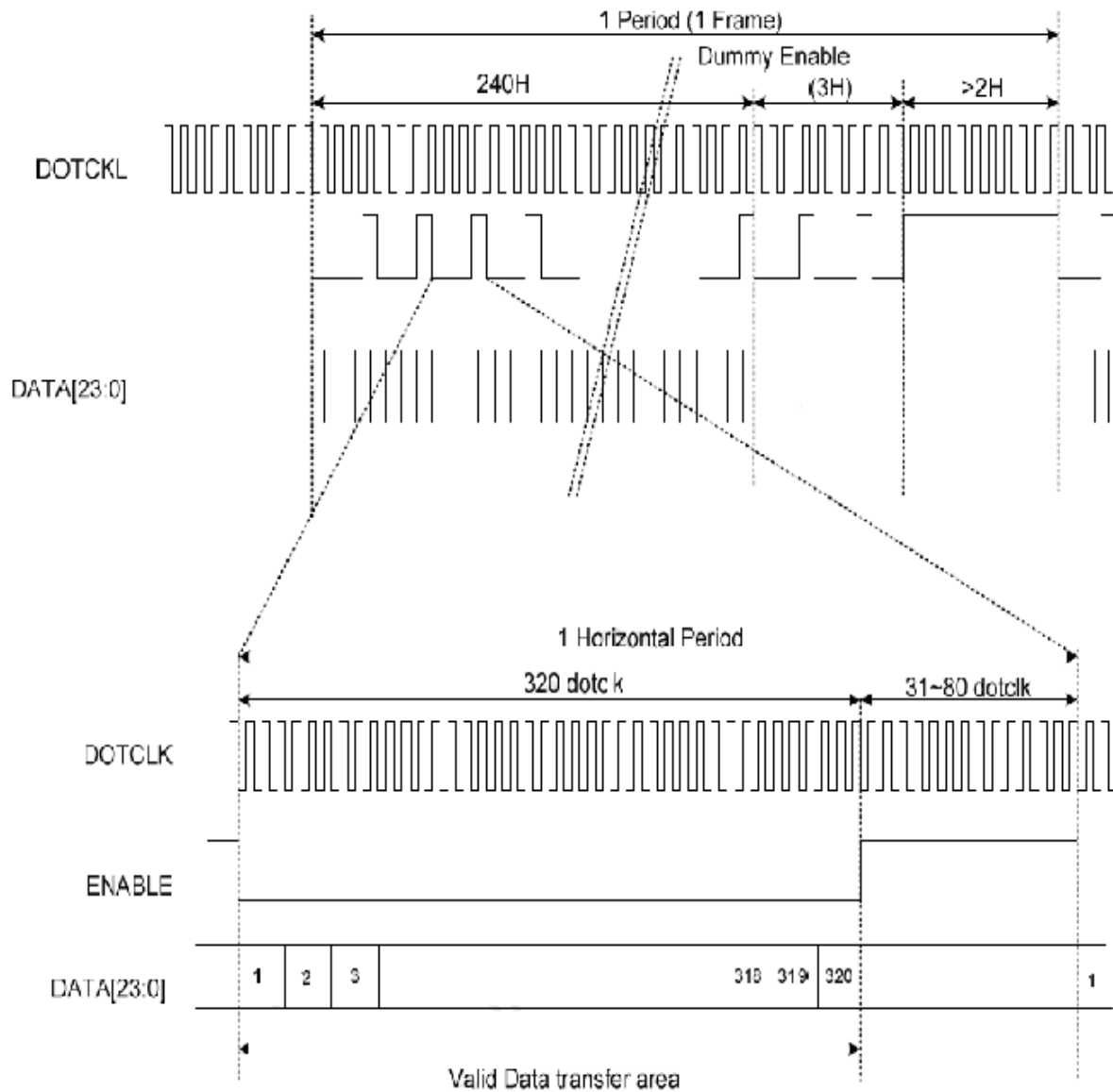

### IHS and horizontal control timing waveforms

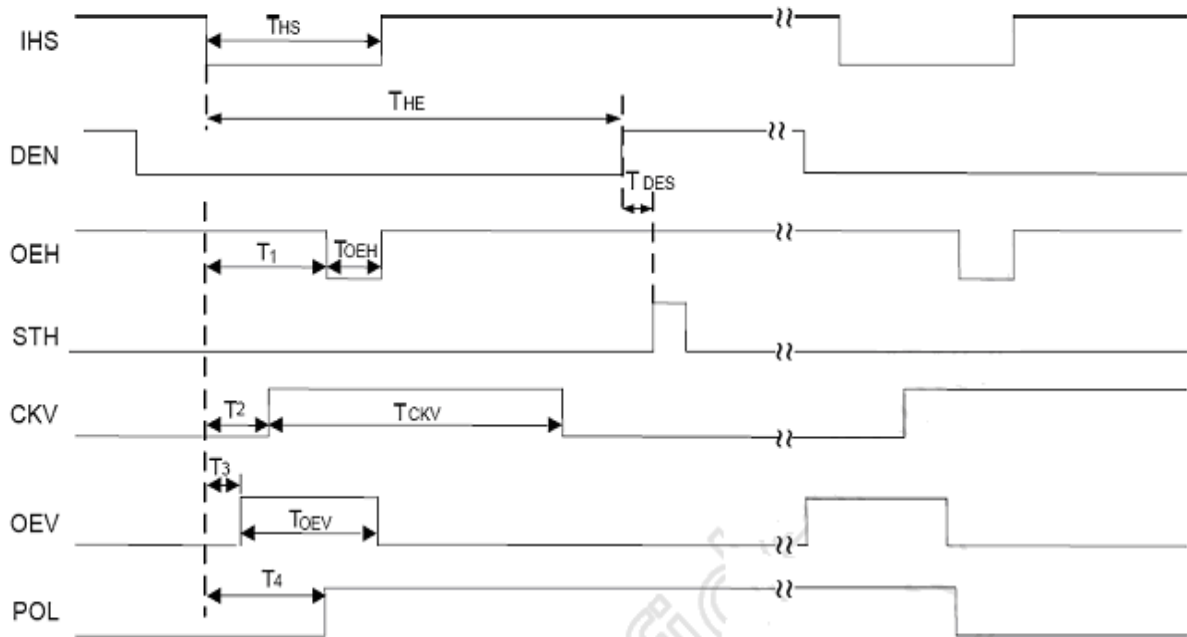

### IHS and vertical shift clock timing waveforms

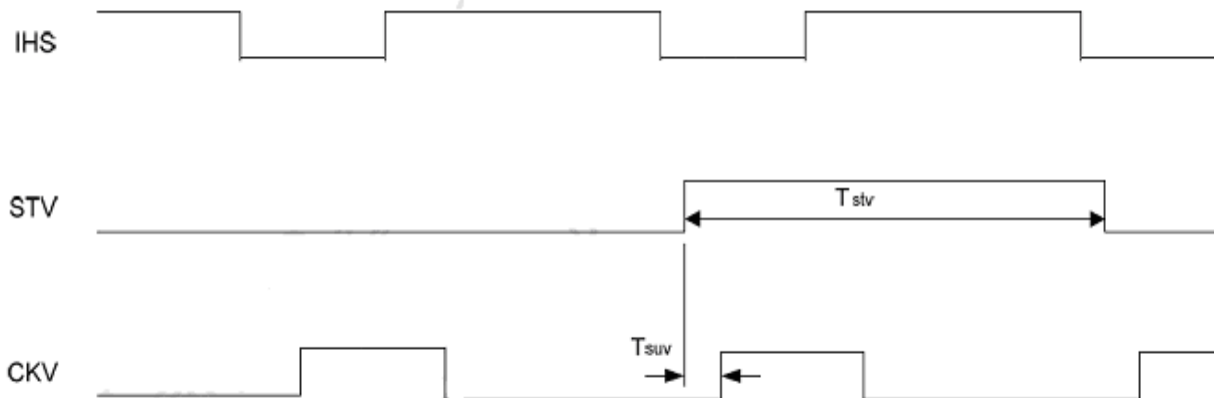

### 3. OPTICAL CHARACTERISTICS

#### 3.1 Characteristics

##### Electrical and Optical Characteristics

No.	Item	symbol / temp.	Min.	Typ.	Max.	Unit	Note		
1	Response Time	Tr	25 °C	-	15	30	ms	2	
		Tf	25 °C	-	35	50			
2	Viewing Angle	Hor.	$\Theta_{x+}$	Center CR>=10	-	60	-	degree	3
			$\Theta_{x-}$		-	60	-		
		Ver.	$\Theta_{Y+}$		-	45	-		
			$\Theta_{Y-}$		-	60	-		
3	Contrast Ratio	Cr	25 °C	150	200	-	-	4	
4	Red x-code	Rx	25 °C	TBD	TBD	TBD	-	5	
	Red y-code	Ry		TBD	TBD	TBD			
	Green x-code	Gx		TBD	TBD	TBD			
	Green y-code	Gy		TBD	TBD	TBD			
	Blue x-code	Bx		TBD	TBD	TBD			
	Blue y-code	By		TBD	TBD	TBD			
	White x-code	Wx		TBD	TBD	TBD			
	White y-code	Wy		TBD	TBD	TBD			
	Brightness	Y		<b>500</b>	-	-	cd/m <sup>2</sup>		
5	Brightness Uniformity		25 °C	<b>80</b>	-	-	%	6	

### 3.2 Definition of optical characteristics

#### Measurement condition :

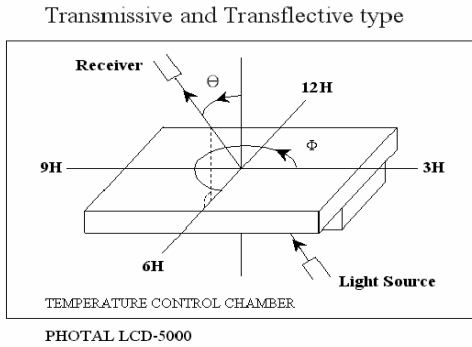

#### [Note 1] Definition of LCD Driving Vop and Waveform :

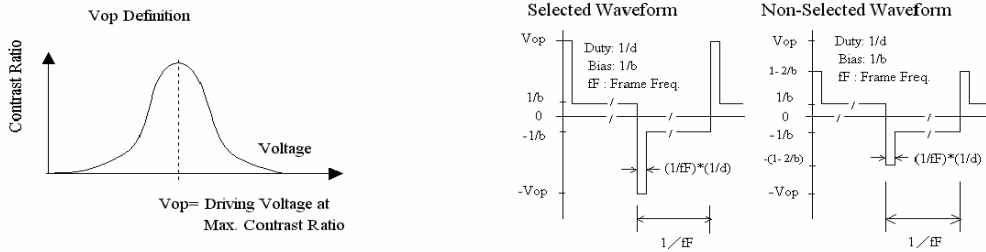

#### [Note 2] Definition of Response Time

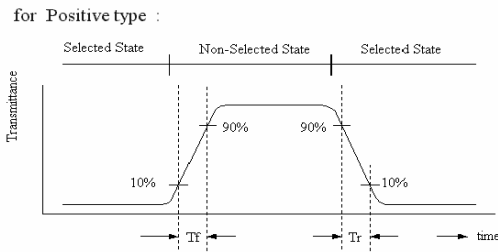

#### [Note 3] Definition of Viewing Angle :

#### [Note 4] Definition of Contrast Ratio :

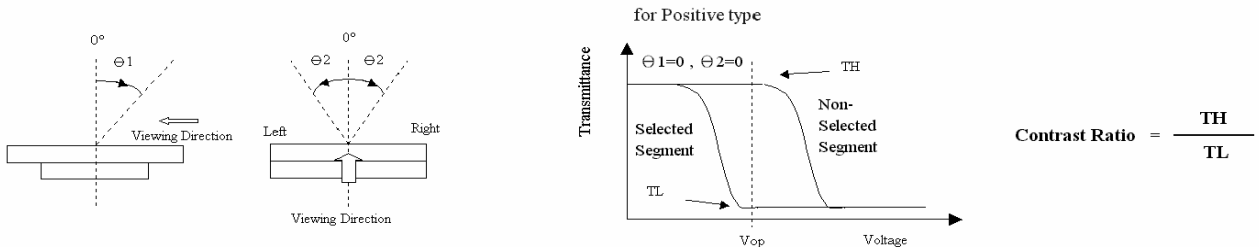

**[Note 5] Definition of measurement of Color Chromaticity and Brightness**

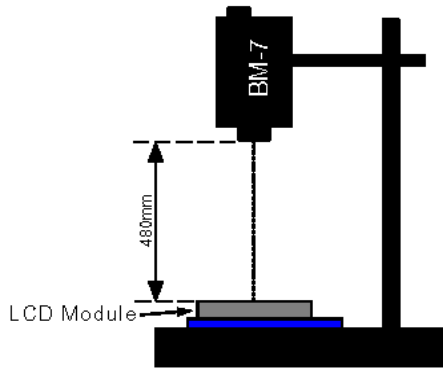

**[Note 6] Definition of Brightness Uniformity**

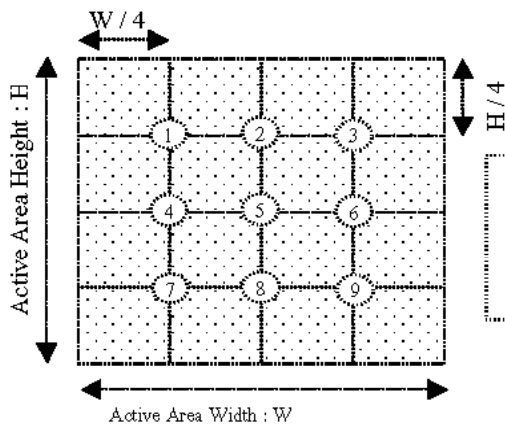

$$\text{Brightness Uniformity} = \frac{\text{Minimum Brightness of Point 1~9}}{\text{Maximum Brightness of Point 1~9}}$$

**[Note 7] Definition of Measurement of Reflectance**

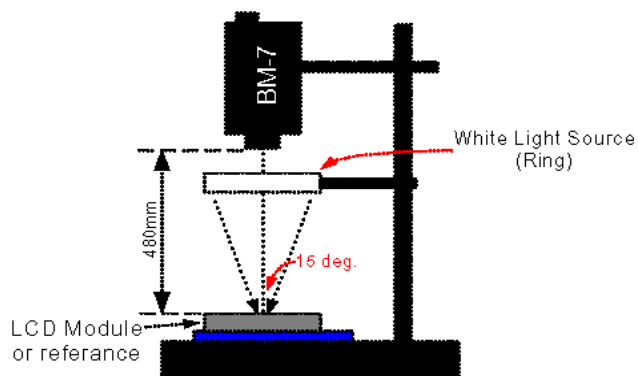



#### 4. RELIABILITY :

Item No	Items	Condition	Remark
1	High temperature operating	70 °C , 200 hours	Finish product (With polarizer)
2	Low temperature operating	-20 °C , 200 hours	Finish product (With polarizer)
3	High temperature storage	80 °C , 200 hours	Finish product (With polarizer)
4	Low temperature storage	-30 °C , 200 hours	Finish product (With polarizer)
5	High temperature & humidity storage	60°C, 90%RH, 100 hours	Finish product (With polarizer)
6	Thermal Shock storage	-30°C, 30min.<=> 80°C, 30min. 10 Cycles	Finish product (With polarizer)
7	Vibration test	10 => 55 =>10 => 55 => 10 Hz , within 1 minute Amplitude : 1.5mm. 15 minutes for each Direction ( X,Y,Z )	Finish product (With polarizer)
8	Drop test	Packed, 100CM free fall, 6 sides, 1 corner, 3edges	Finish product (With polarizer)
9	Life time	50,000 hours 25°C , 70%RH below , specification condition driving	Finish product (With polarizer)

- \* One single product test for only one item.
- \* Judgment after test : keep in room temperature for more than 2 hours.
  - Current consumption < 2 times of initial value
  - Contrast > 1/2 initial value
  - Function : work normally

Date : Nov. 14, 2008

TECHNICAL SPECIFICATION

**HYES**

LCM

HT2501ULH

Page 17 of 25

## 5. PRODUCT HANDLING AND APPLICATION

### PRECAUTION FOR HANDLING LCM

- The LCD module contains a C-MOS LSI. People who operate the LCM should wear ESD protection equipment to prevent ESD hurt on products.
- Do not input any signal before power is turned on.
- Do not take LCM from its packaging bag until it is assembled.
- Peel off the LCM protective film slowly since static electricity may be generated.
- Pay attention to the humidity of the work shop, 50~60%RH is satisfactory.
- Use a non-leak iron for soldering LCM.
- Do not touch the display surface or connection terminals area with bare hands. Smudges on the display surface reduce the insulation between terminals.
- Cautions for soldering to LCM:  
Condition for soldering I/O terminals:  
Temperature at iron tip :280°C±10°C.  
Soldering time : 3~4sec./ terminals.  
Type of solder : Eutectic solder(rosin flux filled).

### PRECAUTION IN USE OF LCD

- Do not contact or scratch the front surface and the contact pads of a LCD panel with hard materials such as metal or glass or with one's nail.
- To clean the surface , wipe it gently with soft cloth dampened by alcohol.
- Do not attempt to wipe off the contact pads.
- Keep LCD panels away from direct sunlight , also avoid them in high-temperature & high humidity environment for a long period.
- Do not drive LCD panels by DC voltage.
- Do not expose LCD panels to organic solvent.
- Liquid in LCD is hazardous substance. In case a contact with liquid crystal material is occurred, be sure to immediately wash such material away by soap and water.
- The polarizer is easily damaged and should be handle with special care. Don't press or rub it with hard objects.

### PRECAUTION FOR STORING LCM

- To avoid degradation of the device , do not store the module under the conditions of direct sunlight , high temperature or high humidity . Keep the module in bags designed to prevent static electricity charging under low temperature / normal humidity conditions(avoid high temperature / high humidity and low temperature below 0°C)

### USING ON MEDICAL CARE , SAFETY OR HAZARDOUS APPLICATION OR SYSTEM

- For the application in medical care, safety and hazardous products or systems, an authorization from **HYES** is required. **HYES** will not responsible for any damage or loss which caused by the products without any authorization given by **HYES**.
- This product is not allowed to be designed and used for military application and/or purpose.
- The delivery of this product to the countries and/or regions where the embargoes are imposed by U.N. is prohibited.
- The application and delivery of this product must comply with Strategic High-Tech Commodities (SHTC) export control and the sales to the embargoed and/or sanctioned countries or regions are strictly prohibited.

Date : Nov. 14, 2008

TECHNICAL SPECIFICATION

**HYES**

LCM

HT2501ULH

Page 18 of 25

## 6. DATE CODE OF PRODUCTS

- Date code will be shown on each product :

- **Y MM DD - XXX**

Year Month Day - Production lots

- Example: 2 1 2 2 3 - 0 0 3 ==> Year 2002, Dec.,23rd , Batch no.03

# 7. PACKING

Instruction of lot number:

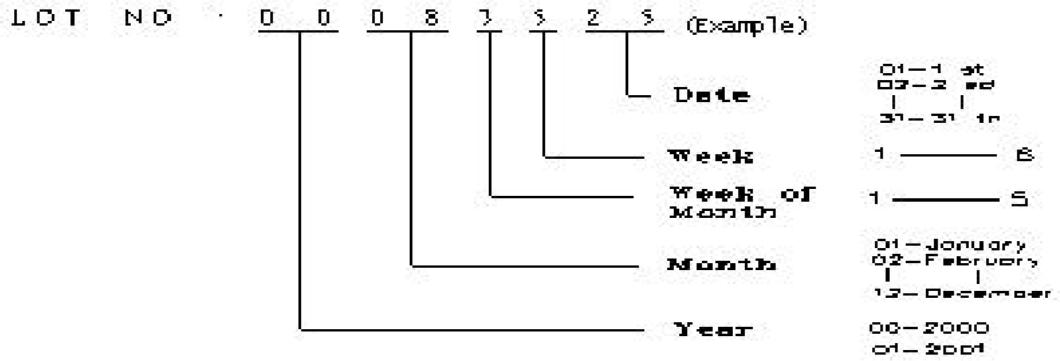

Label of carton:

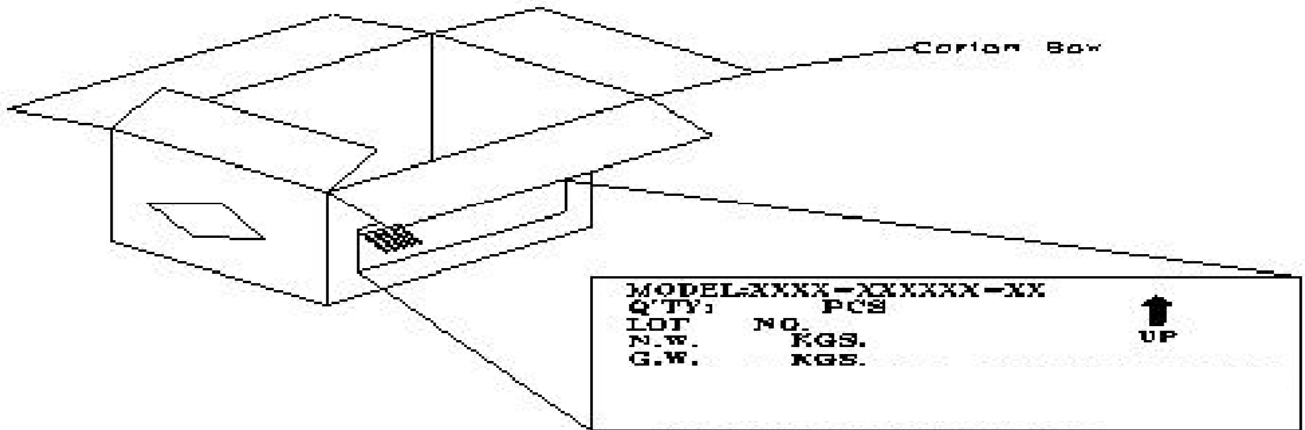

Packing tray must be stacked with alternated direction to each others.  
To tacks packing trays in same direction will cause product damaged.

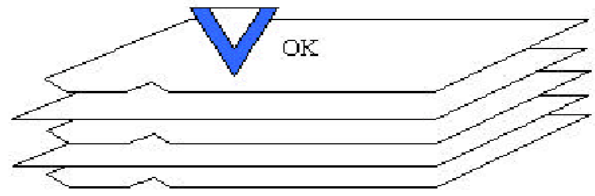
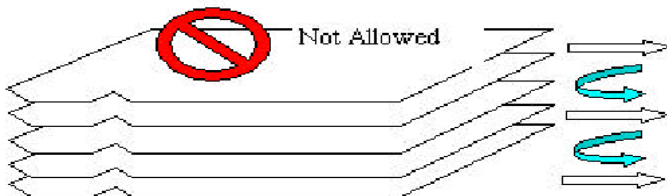
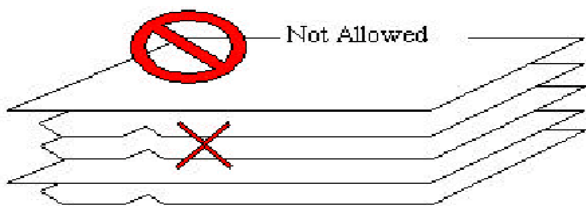

Date : Nov. 14, 2008

TECHNICAL SPECIFICATION

**HYES**

LCM

HT2501ULH

Page 20 of 25

**NOTE:**

- T.B.D** pcs / Tray
- T.B.D** Tray / Box
- T.B.D** Box / Carton
- T.B.D** pcs / Carton

- (1) Be warned ,the direction of the tray has to turn it by 180 degree before stack it up. Otherwise, it will be packager's responsibility!!
- (2) Safe Stack : 5 cartons only

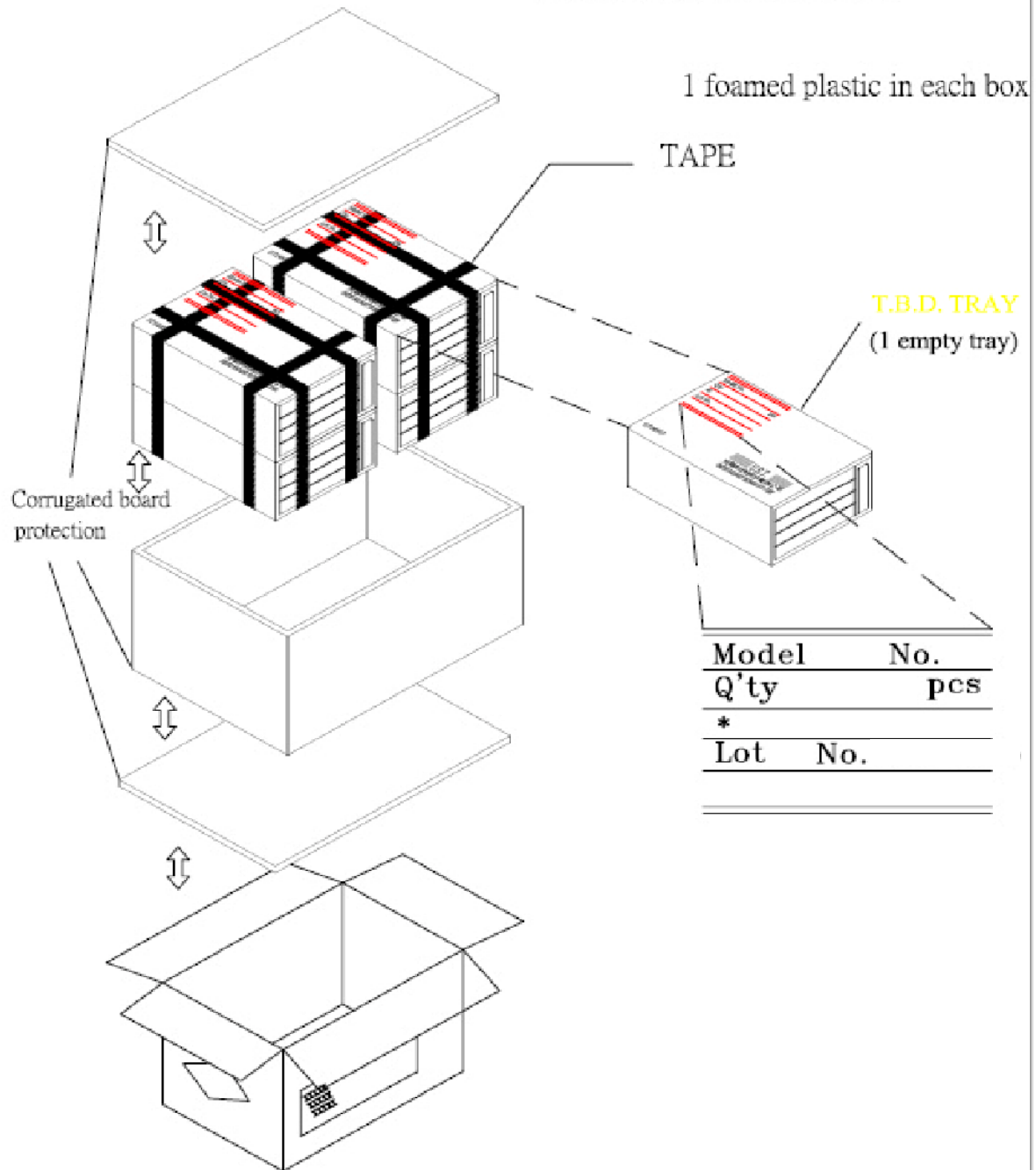

Date : Nov. 14, 2008

TECHNICAL SPECIFICATION

**HYES**

LCM

HT2501ULH

Page 21 of 25

## 8. INSPECTION STANDARD

### 8.1. QUALITY :

THE QUALITY OF GOODS SUPPLIED TO PURCHASER SHALL COME UP TO THE FOLLOWING STANDARD.

#### 8.1.1. THE METHOD OF PRESERVING GOODS

AFTER DELIVERY OF GOODS FROM **HYES** TO PURCHASER. PURCHASER SHALL CONTROL THE LCM AT -10 °C ~ 40 °C ,AND IT MIGHT BE DESIRABLE TO KEEP AT THE NORMAL ROOM TEMPERATURE AND HUMIDITY UNTIL INCOMING INSPECTION OR THROWING INTO PROCESS LINE.

#### 8.1.2. INCOMING INSPECTION

##### (A) THE METHOD OF INSPECTION

IF PURCHASER MAKE AN INCOMING INSPECTION , A SAMPLING PLAN SHALL BE APPLIED ON THE CONDITION THAT QUALITY OF ONE DELIVERY SHALL BE REGARDED AS ONE LOT.

##### (B) THE STANDARD OF QUALITY

ISO-2859-1 ( or MIL-STD-105D ), LEVEL II SINGLE PLAN.

CLASS	AQL(%)
CRITICAL	0.4 %
MAJOR	0.65 %
MINOR	1.5 %
TOTAL	1.5 %

EVERY ITEM SHALL BE INSPECTED ACCORDING TO THE CLASS.

##### (C) MEASURE

IF AS THE RESULT OF ABOVE RECEIVING INSPECTION , A LOT OUT IS DISCOVERED.

PURCHASER SHALL BE INFORM SELLER OF IT WITHIN SEVEN DAYS. BUT FIRST SHIPMENT WITHIN FOURTEEN DAYS.

#### 8.1.3. WARRANTY POLICY

**HYES** WILL PROVIDE ONE-YEAR WARRANTY FOR THE PRODUCTS ONLY IF UNDER SPECIFICATION OPERATING CONDITIONS. **HYES** WILL REPLACE NEW PRODUCTS FOR THESE DEFECT PRODUCTS WHICH UNDER WARRANTY PERIOD AND BELONG TO THE RESPONSIBILITY OF **HYES**.

## 8.2. CHECKING CONDITION

8.2.1. CHECKING DIRECTION SHALL BE IN THE 45 DEGREE AREA TO FACE THE SAMPLE.

8.2.2. CHECKER SHALL SEE OVER 30 cm. WITH BARE EYES FAR FROM SAMPLE AND USING 2 PCS. OF 20W FLUORESCENT LAMP.

Date : Nov. 14, 2008

TECHNICAL SPECIFICATION

**HYES**

LCM

HT2501ULH

Page 22 of 25

**8.3. INSPECTION PLAN :**

CLASS	ITEM	JUDGEMENT	CLASS
PACKING & INDICATE	1. OUTSIDE AND INSIDE PACKAGE	"MODEL NO.", "LOT NO." AND "QUANTITY" SHOULD INDICATE ON THE PACKAGE.	Minor
	2. MODEL MIXED AND QUANTITY	OTHER MODEL MIXED.....REJECTED QUANTITY SHORT OR OVER.....REJECTED	Critical
	3. PRODUCT INDICATION	"MODEL NO." SHOULD INDICATE ON THE PRODUCT	Major
ASSEMBLY	4. DIMENSION, LCD GLASS SCRATCH AND SCRIBE DEFECT.	ACCORDING TO SPECIFICATION OR DRAWING.	Major
APPEARANCE	5. VIEWING AREA	POLARIZER EDGE OR LCD'S SEALING LINE IS VISABLE IN THE VIEWING AREA .....REJECTED	Minor
	6. BLEMISH - BLACK SPOT - WHITE SPOT IN THE LCD AND LCD GLASS CRACKS	ACCORDING TO STANDARD OF VISUAL INSPECTION ( INSIDE VIEWING AREA )	Minor
	7. BLEMISH - BLACK SPOT WHITE SPOT AND SCRTCH ON THE POLARIZER	ACCORDING TO STANDARD OF VISUAL INSPECTION ( INSIDE VIEWING AREA )	Minor
	8. BUBBLE IN POLARIZER	ACCORDING TO STANDARD OF VISUAL INSPECTION ( INSIDE VIEWING AREA )	Minor
	9. LCD'S RAINBOW COLOR	STRONG DEVIATION COLOR ( OR NEWTON RING) OF LCD.....REJECTED. OR ACCORDING TO LIMITED SAMPLE ( IF NEEDED, AND INSIDE VIEWING AREA )	Minor
ELECTRICAL	10. ELECTRICAL AND OPTICAL CHARACTERISTICS ( CONTRAST - VOP - CHROMATICITY ... ETC )	ACCORDING TO SPECIFICATION OR DRAWING . ( INSIDE VIEWING AREA )	Critical
	11. MISSING PATTERN	MISSING DOT - LINE - CHARACTER .....REJECTED	Critical
	12. SHORT CIRCUIT - WRONG PATTERN DISPLAY	NON DISPLAY - WRONG PATTERN DISPLAY - CURRENT CONSUMPTION OUT OF SPECIFICATION..... REJECTED	Critical
	13. PIN HOLE - PATTERN DEFORMITY	ACCORDING TO STANDARD OF VISUAL INSPECTION	Minor

Date : Nov. 14, 2008

TECHNICAL SPECIFICATION

**HYES**

LCM

HT2501ULH

Page 23 of 25

### 8.4. STANDARD OF VISUAL INSPECTION

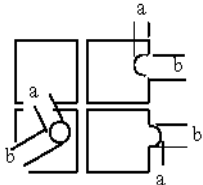
NO.	CLASS	ITEM	JUDGEMENT																									
8.4.1	MINOR	· BLEMISH · BLACK SPOT · WHITE SPOT IN THE LCD.  · BLEMISH · BLACK SPOT · WHITE SPOT AND SCRATCH ON THE POLARIZER	(A) ROUND TYPE: <span style="float: right;">unit : mm.</span> <table border="1"> <thead> <tr> <th>DIAMETER (mm.)</th> <th>ACCEPTABLE Q'TY</th> </tr> </thead> <tbody> <tr> <td><math>\Phi \leq 0.1</math></td> <td>DISREGARD</td> </tr> <tr> <td><math>0.1 &lt; \Phi \leq 0.2</math></td> <td>2</td> </tr> <tr> <td><math>0.2 &lt; \Phi \leq 0.25</math></td> <td>1</td> </tr> <tr> <td><math>0.25 &lt; \Phi</math></td> <td>0</td> </tr> </tbody> </table> NOTE: $\Phi = (\text{LENGTH} + \text{WIDTH}) / 2$ (B) LINER TYPE: <span style="float: right;">unit : mm.</span> <table border="1"> <thead> <tr> <th>LENGTH</th> <th>WIDTH</th> <th>ACCEPTABLE Q'TY</th> </tr> </thead> <tbody> <tr> <td>-----</td> <td><math>W \leq 0.03</math></td> <td>DISREGARD</td> </tr> <tr> <td><math>L \leq 5.0</math></td> <td><math>0.03 &lt; W \leq 0.05</math></td> <td>3</td> </tr> <tr> <td><math>L \leq 5.0</math></td> <td><math>0.05 &lt; W \leq 0.07</math></td> <td>1</td> </tr> <tr> <td>-----</td> <td><math>0.07 &lt; W</math></td> <td>FOLLOW ROUND TYPE</td> </tr> </tbody> </table>	DIAMETER (mm.)	ACCEPTABLE Q'TY	$\Phi \leq 0.1$	DISREGARD	$0.1 < \Phi \leq 0.2$	2	$0.2 < \Phi \leq 0.25$	1	$0.25 < \Phi$	0	LENGTH	WIDTH	ACCEPTABLE Q'TY	-----	$W \leq 0.03$	DISREGARD	$L \leq 5.0$	$0.03 < W \leq 0.05$	3	$L \leq 5.0$	$0.05 < W \leq 0.07$	1	-----	$0.07 < W$	FOLLOW ROUND TYPE
DIAMETER (mm.)	ACCEPTABLE Q'TY																											
$\Phi \leq 0.1$	DISREGARD																											
$0.1 < \Phi \leq 0.2$	2																											
$0.2 < \Phi \leq 0.25$	1																											
$0.25 < \Phi$	0																											
LENGTH	WIDTH	ACCEPTABLE Q'TY																										
-----	$W \leq 0.03$	DISREGARD																										
$L \leq 5.0$	$0.03 < W \leq 0.05$	3																										
$L \leq 5.0$	$0.05 < W \leq 0.07$	1																										
-----	$0.07 < W$	FOLLOW ROUND TYPE																										
8.4.2	MINOR	BUBBLE IN POLARIZER	<span style="float: right;">unit : mm.</span> <table border="1"> <thead> <tr> <th>DIAMETER</th> <th>ACCEPTABLE Q'TY</th> </tr> </thead> <tbody> <tr> <td><math>\Phi \leq 0.15</math></td> <td>DISREGARD</td> </tr> <tr> <td><math>0.15 &lt; \Phi \leq 0.5</math></td> <td>2</td> </tr> <tr> <td><math>0.5 &lt; \Phi</math></td> <td>0</td> </tr> </tbody> </table>	DIAMETER	ACCEPTABLE Q'TY	$\Phi \leq 0.15$	DISREGARD	$0.15 < \Phi \leq 0.5$	2	$0.5 < \Phi$	0																	
DIAMETER	ACCEPTABLE Q'TY																											
$\Phi \leq 0.15$	DISREGARD																											
$0.15 < \Phi \leq 0.5$	2																											
$0.5 < \Phi$	0																											
8.4.3	MINOR	PIN HOLE · PATTERN DEFORMITY	<span style="float: right;">unit : mm.</span>  <table border="1"> <thead> <tr> <th>DIAMETER</th> <th>ACC. Q'TY</th> </tr> </thead> <tbody> <tr> <td><math>\Phi \leq 0.1</math></td> <td>DISREGARD</td> </tr> <tr> <td><math>0.1 &lt; \Phi \leq 0.25</math></td> <td>3</td> </tr> <tr> <td><math>0.25 &lt; \Phi</math></td> <td>0</td> </tr> </tbody> </table> <p><math>\Phi = (a+b)/2</math></p>	DIAMETER	ACC. Q'TY	$\Phi \leq 0.1$	DISREGARD	$0.1 < \Phi \leq 0.25$	3	$0.25 < \Phi$	0																	
DIAMETER	ACC. Q'TY																											
$\Phi \leq 0.1$	DISREGARD																											
$0.1 < \Phi \leq 0.25$	3																											
$0.25 < \Phi$	0																											

Date : Nov. 14, 2008

TECHNICAL SPECIFICATION

**HYES**

LCM

HT2501ULH

Page 24 of 25

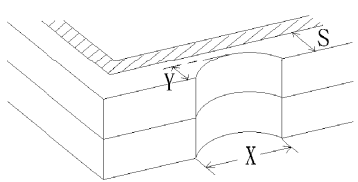
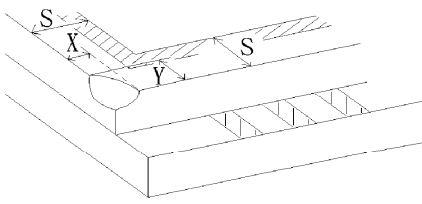
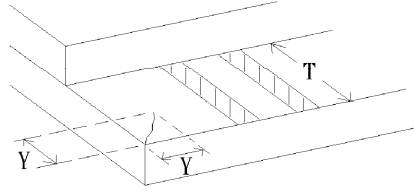
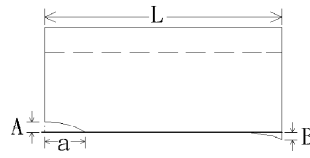
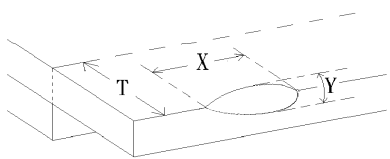
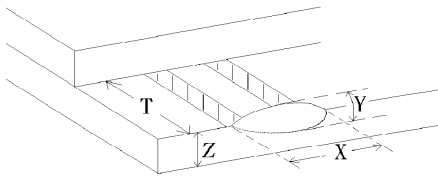
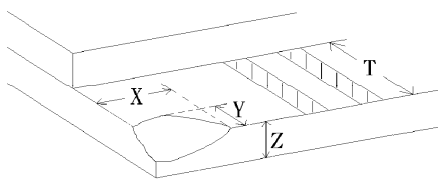

NO.	CLASS	ITEM	JUDGEMENT
8.4.4	MINOR	CHIPPING	 $Y > S$ <b>REJ.</b>
8.4.5	MINOR	CHIPPING	 $X \text{ or } Y > S$ <b>REJ.</b>
8.4.6	MAJOR	GLASS CRACK	 $Y > (1/2) T$ <b>REJ.</b>
8.4.7	MAJOR	SCRIBE DEFECT	 <ol style="list-style-type: none"> <li><math>a &gt; L/3</math>, <math>A &gt; 1.5\text{mm}</math>. <b>REJ.</b></li> <li>B : ACCORDING TO DIMENSION</li> </ol>
8.4.8	MINOR	CHIPPING ( ON THE TERMINAL AREA )	 $\Phi = (x+y)/2 > 2.5 \text{ mm}$ <b>REJ.</b>
8.4.9	MINOR	CHIPPING ( ON THE TERMINAL SURFACE )	 $Y > (1/3) T$ <b>REJ.</b>
8.4.10	MINOR	CHIPPING	 $Y > T$ <b>REJ.</b>

Date : Nov. 14, 2008

TECHNICAL SPECIFICATION

**HYES**

LCM

HT2501ULH

Page 25 of 25