

APPROVAL

PART NO.	DESCRIPTION	REMARKS
HT2801UL	LCD MODULE (240 x RGB x 320)	* This is ROHS compliant

CUSTOMER APPLICATION P/N	
APPROVED BY	
DATE	

PLEASE KINDLY FIND AND APPROVE THE SPECIFICATIONS INSERTED
HEREIN AND RETURN ONE COPY HERE OF WITH YOUR SIGNATURE OF APPROVAL.

PERPARED BY	CHECKED BY	CONFIRMED BY



HYES Optoelectronics, Inc.

2000 Wyatt Drive Suite 6
Santa Clara, CA 95054 USA

CONTENTS:

No.	Item
1	BASIC SPECIFICATION 1.1 Mechanical Specification 1.2 Display Specification 1.3 Outline Dimension 1.4 Block Diagram 1.5 Interface Pin
2	ELECTRICAL CHARACTERISTICS 2.1 Absolute Maximum Ratings 2.2 DC Characteristics 2.2.1 Back-light 2.3 AC Characteristics
3	OPTICAL CHARACTERISTICS 3.1 Condition 3.2 Definition of Optical Characteristics
4	RELIABILITY
5	PRODUCT HANDLING AND APPLICATION
6	DATECODE
7	PACKING & LOTNO
8	INSPECTION STANDARD

Date : Jan. 23, 2008

TECHNICAL SPECIFICATION

The logo for HYES, consisting of the word "HYES" in white capital letters on a dark orange rectangular background.

LCM

HT2801UL

Page 2 of 25

1. BASIC SPECIFICATION

1.1 Mechanical specifications

Items	Nominal Dimension	Unit
Active screen size	2.8" diagonal	-
Dot Matrix	240*RGB*320	dots
Module Size (W x H x T)	50 x 98.2 x 3.8	mm.
Active Area (W x H)	43.2 x 57.6	mm.
Dot Pitch (W x H)	0.18 x 0.18	mm.
Color depth	262K	Color
Interface	8/9/16/18-bit MPU parallel	-
Driving IC Package	COG	-

1.2 Display specification

Display	Descriptions	Note
LCD Type	a-Si TFT	
LCD Mode	TN/Normal white	
Polarizer Mode	Transmissive	
Polarizer Surface	Normal	
Pixel arrangement	RGB-stripe	
Backlight Type	LED	
Viewing Direction	12 O'clock Direction	

* Color tone is slightly changed by temperature and driving voltage.

1.3 Outline dimension

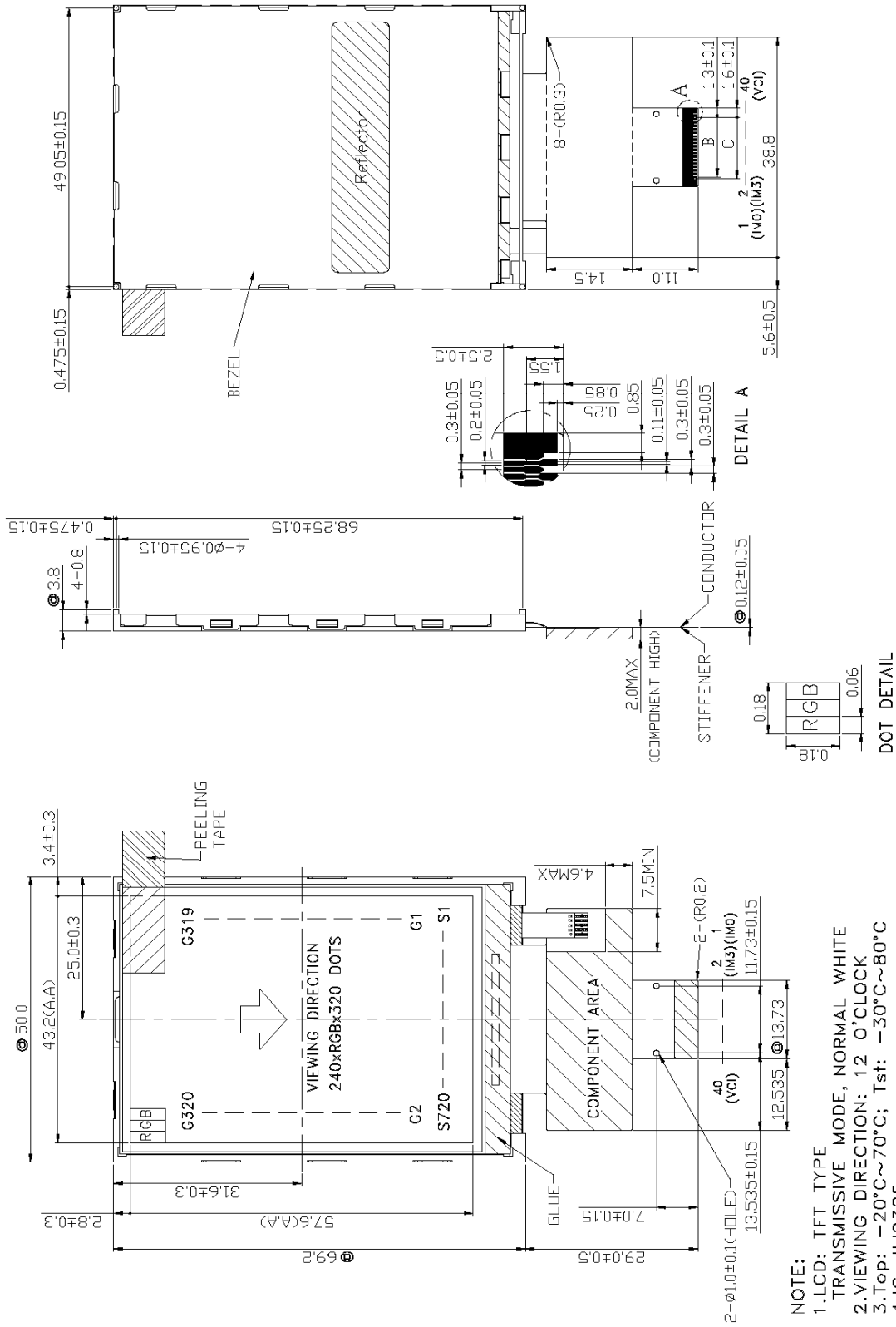

- NOTE:
- 1.LCD: TFT TYPE
TRANSMISSIVE MODE, NORMAL WHITE
 - 2.VIEWING DIRECTION: 12 O'CLOCK
 - 3.Top: -20°C~70°C; Tst: -30°C~80°C
 - 4.IC: ILI9325
 - 5.TOLERANCE FOR NOT ASSIGNED: ±0.2mm
 - 6.LED: WHITE 4 PCS ,Vied = 3.5V(TYP) , IF= 80.0 mA(CONSTANT CURRENT)
 - 7."@" : KEY DIMENSION
 - 8.THE MINIMUM BENDING RADIUS(INNER) OF THE FPC IS 0.5mm
 - 9.B:10.8±0.1(P0.6X18) ; C:10.8±0.1(P0.6X18)

Date : Jan. 23, 2008

TECHNICAL SPECIFICATION



LCM

HT2801UL

Page 4 of 25

1.4 Block diagram:

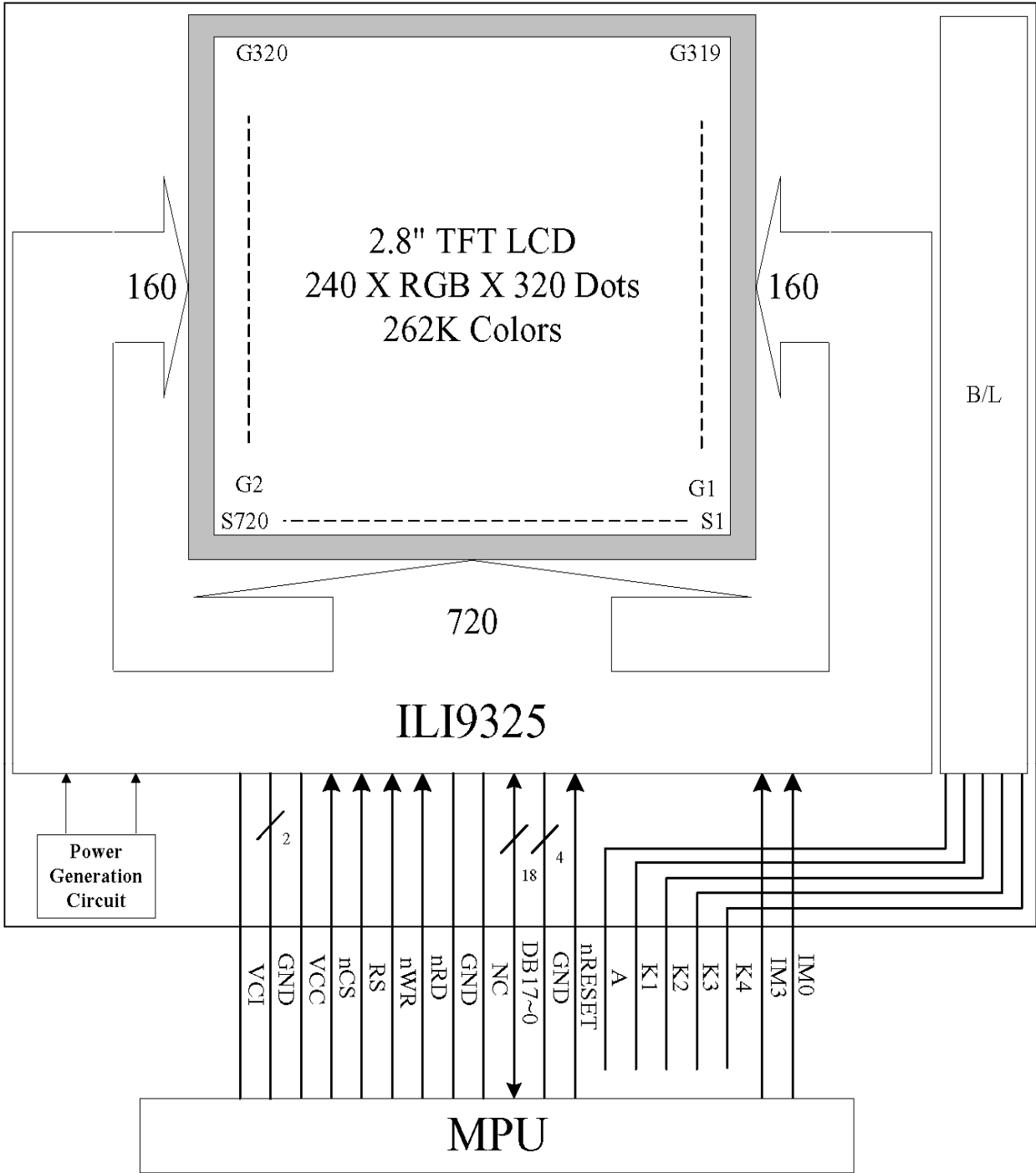

1.5 Interface pin :

Pin No.	Pin Symbol	I/O	Description																	
1	IM0	I	Select the MPU system interface mode																	
			<table border="1"> <thead> <tr> <th>IM3</th> <th>IM0</th> <th>MPU-Interface Mode</th> <th>DB Pin in use</th> </tr> </thead> <tbody> <tr> <td>0</td> <td>0</td> <td>i80-system 16-bit interface</td> <td>DB[17:10], DB[8:1]</td> </tr> <tr> <td>0</td> <td>1</td> <td>i80-system 8-bit interface</td> <td>DB[17:10]</td> </tr> <tr> <td>1</td> <td>0</td> <td>i80-system 18-bit interface</td> <td>DB[17:0]</td> </tr> <tr> <td>1</td> <td>1</td> <td>i80-system 9-bit interface</td> <td>DB[17:9]</td> </tr> </tbody> </table>	IM3	IM0	MPU-Interface Mode	DB Pin in use	0	0	i80-system 16-bit interface	DB[17:10], DB[8:1]	0	1	i80-system 8-bit interface	DB[17:10]	1	0	i80-system 18-bit interface	DB[17:0]	1
IM3	IM0	MPU-Interface Mode	DB Pin in use																	
0	0	i80-system 16-bit interface	DB[17:10], DB[8:1]																	
0	1	i80-system 8-bit interface	DB[17:10]																	
1	0	i80-system 18-bit interface	DB[17:0]																	
1	1	i80-system 9-bit interface	DB[17:9]																	
2	IM3	I	0 0 i80-system 16-bit interface DB[17:10], DB[8:1]																	
			0 1 i80-system 8-bit interface DB[17:10]																	
			1 0 i80-system 18-bit interface DB[17:0]																	
			1 1 i80-system 9-bit interface DB[17:9]																	
3	K4	P	Cathode4 input for LED backlight.																	
4	K3	P	Cathode3 input for LED backlight.																	
5	K2	P	Cathode2 input for LED backlight.																	
6	K1	P	Cathode1 input for LED backlight.																	
7	A	P	Anode input for LED backlight.																	
8	nRESET	I	A reset pin. Initializes the ILI9325 with a low input. Be sure to execute a power-on reset after supplying power.																	
9~12	GND	P	Power Supply for Ground(0V).																	
13~30	DB17~0	I/O	An 18-bit parallel bi-directional data bus for MPU system interface mode 8-bit I/F: DB[17:10] is used. 9-bit I/F: DB[17:9] is used. 16-bit I/F: DB[17:10] and DB[8:1] is used. 18-bit I/F: DB[17:0] is used. Unused pins must be fixed to GND level.																	
31	NC	-	No connection.																	
32	GND	P	Power Supply for Ground(0V).																	
33	nRD	I	A read strobe signal and enables an operation to read out data when the signal is low.																	
34	nWR	I	A write strobe signal and enables an operation to write data when the signal is low.																	
35	RS	I	A register select signal. Low: select an index or status register. High: select a control register.																	
36	nCS	I	A chip select signal. Low: the ILI9325 is selected and accessible. High: the ILI9325 is not selected and not accessible.																	
37	VCC	P	A supply voltage to the internal logic: VCC = (+2.8V).																	
38~39	GND	P	Power Supply for Ground(0V).																	
40	VCI	P	A supply voltage to the analog circuit. VCI = (+2.8V).																	

Date : Jan. 23, 2008

TECHNICAL SPECIFICATION

HYES

LCM

HT2801UL

Page 6 of 25

2. ELECTRICAL CHARACTERISTICS

2.1 Absolute Maximum Ratings

Items	Symbol	Min.	Max.	Unit
Supply voltage for logics	VCC	-0.3	+4.6	V
Supply voltage for analog	VCI	-0.3	+4.6	V
Input voltage	V _i	-0.3	VCC+0.3	V
Operating temperature range	T _{OP}	-20	+70	°C
Storage temperature range	T _{ST}	-30	+80	°C

2.2 DC Characteristics

Items	Symbol	Min.	Typ.	Max.	Unit	Condition
Supply voltage (Logic)	VCC	2.4	2.8	3.3	V	NOTE
Supply voltage (analog)	VCI	1.65	2.8	3.3	V	NOTE
Input high level voltage	V _{IH}	0.8VCC	-	VCC	V	-
Input low level voltage	V _{IL}	-0.3	-	0.2VCC	V	-
Power supply current	I _{CC} +I _{CI}	-	-	14	mA	NOTE

NOTE :

Measuring Condition :

Standard Value MAX.

T_a = 25°C

VCC-VSS = +2.8V

VCI-VSS = +2.8V

Fosc ≐ 512KHz

Display Patten = Checkered pattern

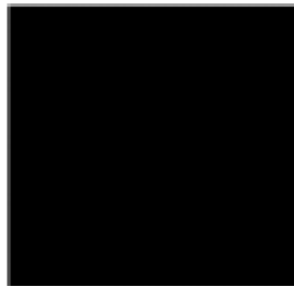

0 gray black pattern

2-2.1 Back-light Characteristics

PARAMETER	SYMBOL	MIN	TYP	MAX	Unit	Test Condition	NOTE
Supply Current	I _f	-	80	-	mA	T _a =25°C	-
Supply Voltage	V _s	-	3.3	-	V	T _a =25°C	-
Brightness	Br	2400	-	-	cd/m ²	T _a =25°C I _f =80mA	-
Half-Life Time	L _f	-	10000	-	hrs	T _a =25°C	1

Note 1 : The " Half-Life Time "is defined as the module brightness decrease to 50% original brightness.

Date : Jan. 23, 2008

TECHNICAL SPECIFICATION

HYES

LCM

HT2801UL

Page 8 of 25

2-3 Command Sequence

LCD_Initial_ILI-9325:

Start Initial Sequence:

COMMAND	CODE	DESCRIPTION
--	LCD_RESET=1 delay 1ms LCD_RESET=0 delay 10ms LCD_RESET=1 delay 50ms	
Driver Output Control	0001H 0100H	set SS and SM bit
LCD Driving Wave Control	0002H 0700H	set 1 line inversion
Entry Mode	0003H 1030H	set GRAM write direction and BGR=1.
Resizing Control Register	0004H 0000H	Resize register
Display Control 2	0008H 0207H	set the back porch and front porch
Display Control 3	0009H 0000H	set non-display area refresh cycle ISC[3:0]
Display Control 4	000AH 0000H	FMARK function
RGB Display Interface Control 1	000CH 0000H	RGB interface setting
Frame Marker Position	000DH 0000H	Frame marker Position
RGB Display Interface Control 2	000FH 0000H	RGB interface polarity

Date : Jan. 23, 2008

TECHNICAL SPECIFICATION

HYES

LCM

HT2801UL

Page 9 of 25

Power On sequence:

COMMAND	CODE	DESCRIPTION
Power Control 1	0010H 0000H	SAP, BT[3:0], AP, DSTB, SLP, STB
Power Control 2	0011H 0007H	DC1[2:0], DC0[2:0], VC[2:0]
Power Control 3	0012H 0000H	VREG1OUT voltage
Power Control 4	0013H 0000H delay 200ms	VDV[4:0] for VCOM amplitude
Power Control 1	0010H 1490H	SAP, BT[3:0], AP, DSTB, SLP, STB
Power Control 2	0011H 0227H delay 50ms	DC1[2:0], DC0[2:0], VC[2:0]
Power Control 3	0012H 001DH delay 50ms	External reference voltage= Vci;
Power Control 4	0013H 0800H	VDV[4:0] for VCOM amplitude
Power Control 7	0029H 0014H	VCM[5:0] for VCOMH
Frame Rate and Color Control	002BH 000DH delay 50ms	Set Frame Rate
GRAM Horizontal/Vertical Address Set	0020H 0000H	GRAM horizontal Address
GRAM Horizontal/Vertical Address Set	0021H 0000H	GRAM Vertical Address

Date : Jan. 23, 2008

TECHNICAL SPECIFICATION

HYES

LCM

HT2801UL

Page 10 of 25

Adjust the Gamma Curve:

COMMAND	CODE	DESCRIPTION
Gamma Control 1	0030H 0007H	
Gamma Control 2	0031H 0707H	
Gamma Control 3	0032H 0006H	
Gamma Control 4	0035H 0704H	
Gamma Control 5	0036H 1F04H	
Gamma Control 6	0037H 0004H	
Gamma Control 7	0038H 0000H	
Gamma Control 8	0039H 0706H	
Gamma Control 9	003CH 0701H	
Gamma Control 10	003DH 000FH	

Set GRAM area:

COMMAND	CODE	DESCRIPTION
Horizontal Address Start Position	0050H 0000H	Horizontal GRAM Start Address
Horizontal Address End Position	0051H 00EFH	Horizontal GRAM End Address
Vertical Address Start Position	0052H 0000H	Vertical GRAM Start Address
Vertical Address End Position	0053H 013FH	Vertical GRAM Start Address

Date : Jan. 23, 2008

TECHNICAL SPECIFICATION

HYES

LCM

HT2801UL

Page 11 of 25

COMMAND	CODE	DESCRIPTION
Driver Output Control 2	0060H A700H	Gate Scan Line
Base Image Display Control	0061H 0001H	NDL,VLE, REV
Vertical Scroll Control	006AH 0000H	set scrolling line

Partial Display Control:

COMMAND	CODE	DESCRIPTION
Partial Image 1 Display Position	0080H 0000H	
Partial Image 1 Area (Start Line)	0081H 0000H	
Partial Image 1 Area (End Line)	0082H 0000H	
Partial Image 2 Display Position	0083H 0000H	
Partial Image 2 Area (Start Line)	0084H 0000H	
Partial Image 2 Area (End Line)	0085H 0000H	

Panel Control:

Panel Interface Control 1	0090H 0010H	
Panel Interface Control 2	0092H 0600H	
Panel Interface Control 3	0093H 0003H	
Panel Interface Control 4	0095H 0110H	
Panel Interface Control 5	0097H 0000H	
Panel Interface Control 6	0098H 0000H	
Display Control 1	0007H 0133H	262K color and display ON

Date : Jan. 23, 2008

TECHNICAL SPECIFICATION

HYES

LCM

HT2801UL

Page 12 of 25

2.4 AC Characteristics

2.4-1 I80-System Interface Timing Characteristics

Item	Symbol	Unit	Min.	Typ.	Max.	Test Condition
Bus cycle time	Write	t_{BCW}	ns	100	-	-
	Read	t_{BCR}	ns	300	-	-
Write low-level pulse width	PW_{LW}	ns	50	-	500	-
Write high-level pulse width	PW_{HW}	ns	50	-	-	-
Read low-level pulse width	PW_{LR}	ns	150	-	-	-
Read high-level pulse width	PW_{HR}	ns	150	-	-	-
Write / Read rise / fall time	t_{WR}/t_{WR}	ns	-	-	25	-
Setup time	Write (RS to nCS, E/nWR)	t_{AS}	ns	10	-	-
	Read (R3 to nCS, RW/nRD)			5	-	-
Address hold time	t_{AH}	ns	5	-	-	-
Write data set up time	t_{DSW}	ns	10	-	-	-
Write data hold time	t_H	ns	15	-	-	-
Read data delay time	t_{DDR}	ns	-	-	100	-
Read data hold time	t_{DHR}	ns	5	-	-	-

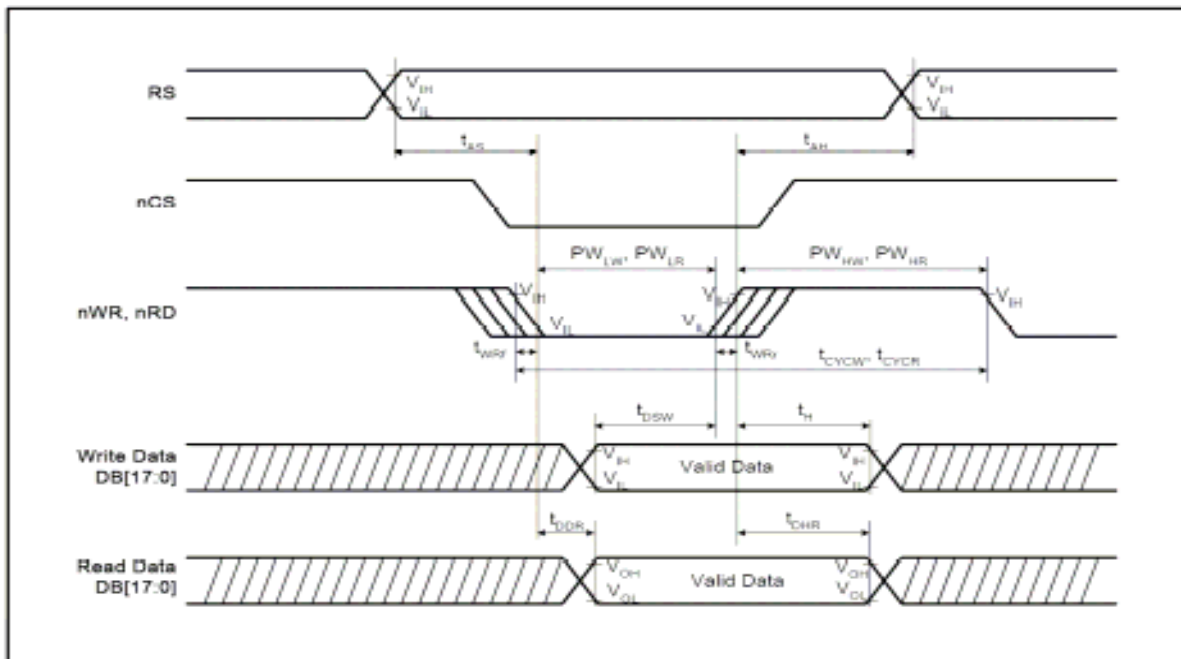

2.4-2 Reset Timing Characteristics

Item	Symbol	Unit	Min.	Typ.	Max.
Reset low-level width	t_{RES}	ms	1	-	-
Reset rise time	t_{RES}	μ s	-	-	10

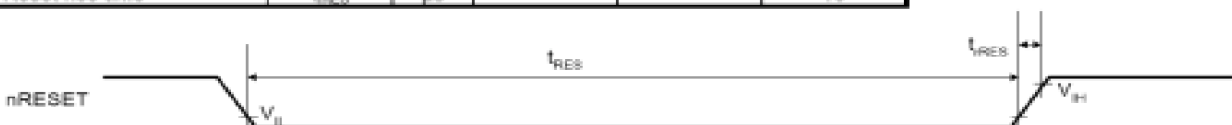

Date : Jan. 23, 2008

TECHNICAL SPECIFICATION

HYES

LCM

HT2801UL

Page 13 of 25

3. OPTICAL CHARACTERISTICS

3.1 Characteristics

Electrical and Optical Characteristics

No.	Item	symbol / temp.	Min.	Typ.	Max.	Unit	Note	
1	Response Time	Tr	25 °C	NA	15	ms	2	
		Tf	25 °C	NA	35			50
2	Viewing Angle	Front-Rear $\Theta 1$	Φ $\approx 270^\circ$	-35	-	45		
		Left-Right $\Theta 2$		-60	-	60		
3	Contrast Ratio	Cr	25 °C	150	250	-	4	
4	Red x-code	Rx	25 °C	0.57	0.62	0.67	-	5
	Red y-code	Ry		0.29	0.34	0.39		
	Green x-code	Gx		0.29	0.34	0.39		
	Green y-code	Gy		0.53	0.58	0.63		
	Blue x-code	Bx		0.09	0.14	0.19		
	Blue y-code	By		0.03	0.08	0.13		
	White x-code	Wx		0.24	0.29	0.34		
	White y-code	Wy		0.25	0.30	0.35		
	Brightness	Y		150	200	-		
5	Brightness Uniformity		25 °C	80	-	-	%	6

3.2 Definition of optical characteristics

Measurement condition :

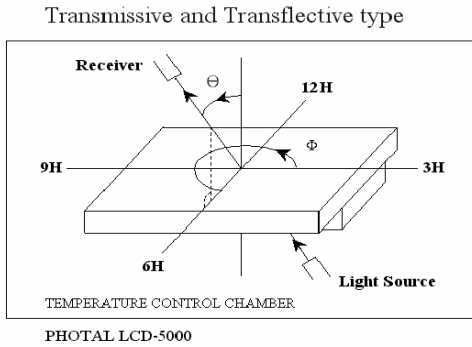

[Note 1] Definition of LCD Driving Vop and Waveform :

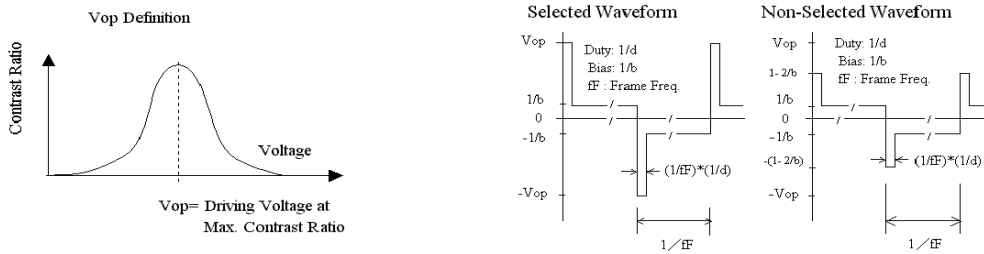

[Note 2] Definition of Response Time

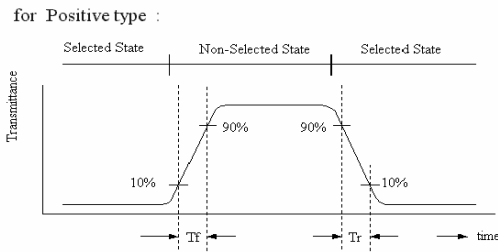

[Note 3] Definition of Viewing Angle :

[Note 4] Definition of Contrast Ratio :

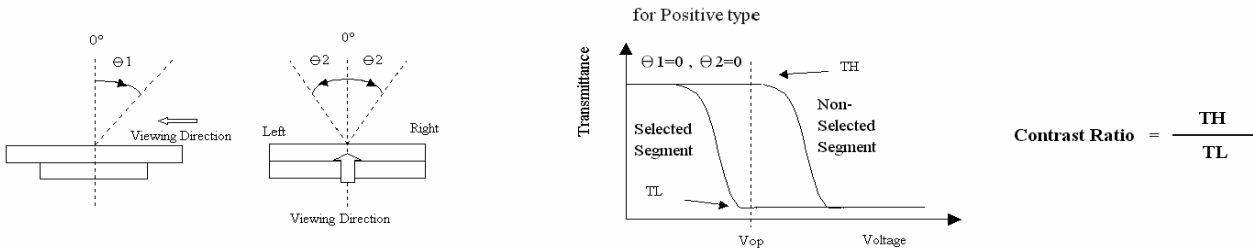

Date : Jan. 23, 2008

TECHNICAL SPECIFICATION

HYES

LCM

HT2801UL

Page 15 of 25

[Note 5] Definition of measurement of Color Chromaticity and Brightness

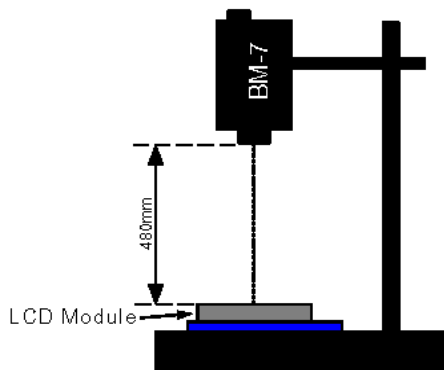

[Note 6] Definition of Brightness Uniformity

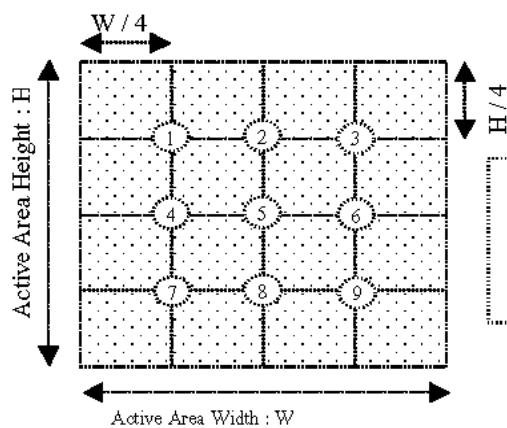

$$\text{Brightness Uniformity} = \frac{\text{Minimum Brightness of Point 1~9}}{\text{Maximum Brightness of Point 1~9}}$$

[Note 7] Definition of Measurement of Reflectance

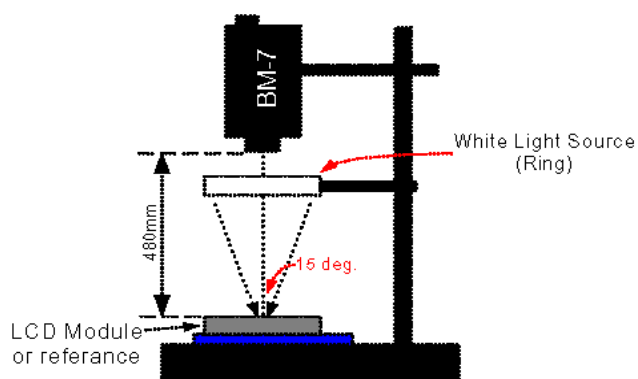

4. RELIABILITY :

Item No	Items	Condition
1	High temperature operating	70 °C , 200 hours
2	Low temperature operating	-20 °C , 200 hours
3	High temperature storage	80 °C , 200 hours
4	Low temperature storage	-30 °C , 200 hours
5	High temperature & humidity storage	60°C, 90%RH, 100 hours
6	Thermal Shock storage	-30°C, 30min.<=> 80°C, 30min. 10 Cycles
7	Vibration test	10 => 55 =>10 => 55 => 10 Hz , within 1 minute Amplitude : 1.5mm. 15 minutes for each Direction (X,Y,Z)
8	Drop test	Packed, 100CM free fall, 6 sides, 1 corner, 3edges
9	Life time	50,000 hours 25°C , 70%RH below , specification condition driving

* One single product test for only one item.

* Judgment after test : keep in room temperature for more than 2 hours.

- Current consumption < 2 times of initial value
- Contrast > 1/2 initial value
- Function : work normally

5. PRODUCT HANDING AND APPLICATION

PRECAUTION FOR HANDLING LCM

- The LCD module contains a C-MOS LSI. People who operate the LCM should wear ESD protection equipment to prevent ESD hurt on products.
- Do not input any signal before power is turned on.
- Do not take LCM from its packaging bag until it is assembled.
- Peel off the LCM protective film slowly since static electricity may be generated.
- Pay attention to the humidity of the work shop, 50~60%RH is satisfactory.
- Use a non-leak iron for soldering LCM.
- Do not touch the display surface or connection terminals area with bare hands. Smudges on the display surface reduce the insulation between terminals.
- Cautions for soldering to LCM:
Condition for soldering I/O terminals:
Temperature at iron tip :280°C±10°C.
Soldering time : 3~4sec./ terminals.
Type of solder : Eutectic solder(rosin flux filled).

PRECAUTION IN USE OF LCD

- Do not contact or scratch the front surface and the contact pads of a LCD panel with hard materials such as metal or glass or with one's nail.
- To clean the surface , wipe it gently with soft cloth dampened by alcohol.
- Do not attempt to wipe off the contact pads.
- Keep LCD panels away from direct sunlight , also avoid them in high-temperature & high humidity environment for a long period.
- Do not drive LCD panels by DC voltage.
- Do not expose LCD panels to organic solvent.
- Liquid in LCD is hazardous substance. In case a contact with liquid crystal material is occurred, be sure to immediately wash such material away by soap and water.
- The polarizer is easily damaged and should be handle with special care. Don't press or rub it with hard objects.

PRECAUTION FOR STORING LCM

- To avoid degradation of the device , do not store the module under the conditions of direct sunlight , high temperature or high humidity . Keep the module in bags designed to prevent static electricity charging under low temperature / normal humidity conditions(avoid high temperature / high humidity and low temperature below 0°C)

USING ON MEDICAL CARE , SAFETY OR HAZARDOUS APPLICATION OR SYSTEM

- For the application in medical care, safety and hazardous products or systems, an authorization from HYES is required. HYES will not responsible for any damage or loss which caused by the products without any authorization given by HYES.
- This product is not allowed to be designed and used for military application and/or purpose.
- The delivery of this product to the countries and/or regions where the embargoes are imposed by U.N. is prohibited.

Date : Jan. 23, 2008

TECHNICAL SPECIFICATION

HYES

LCM

HT2801UL

Page 18 of 25

6. DATE CODE OF PRODUCTS

- Date code will be shown on each product :

- **Y MM DD - XXX**

Year Month Day - Production lots

- Example: 2 1 2 3 - 0 0 3 ==> Year 2002, Dec.,23rd , Batch no.03

7. PACKING

Instruction of lot number:

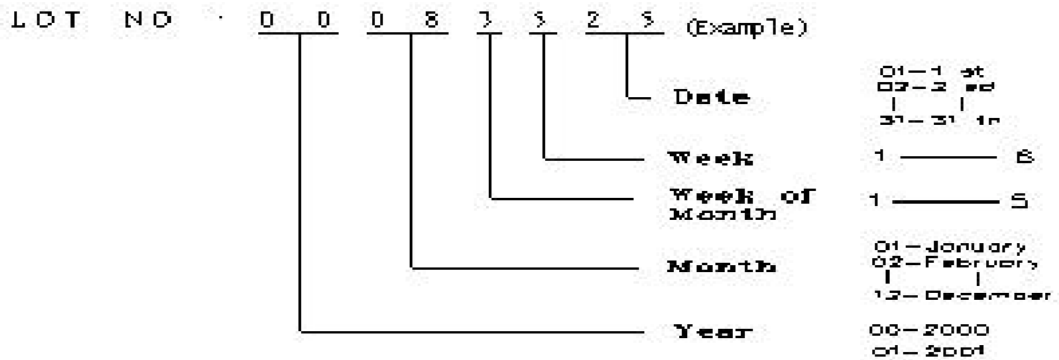

Label of carton:

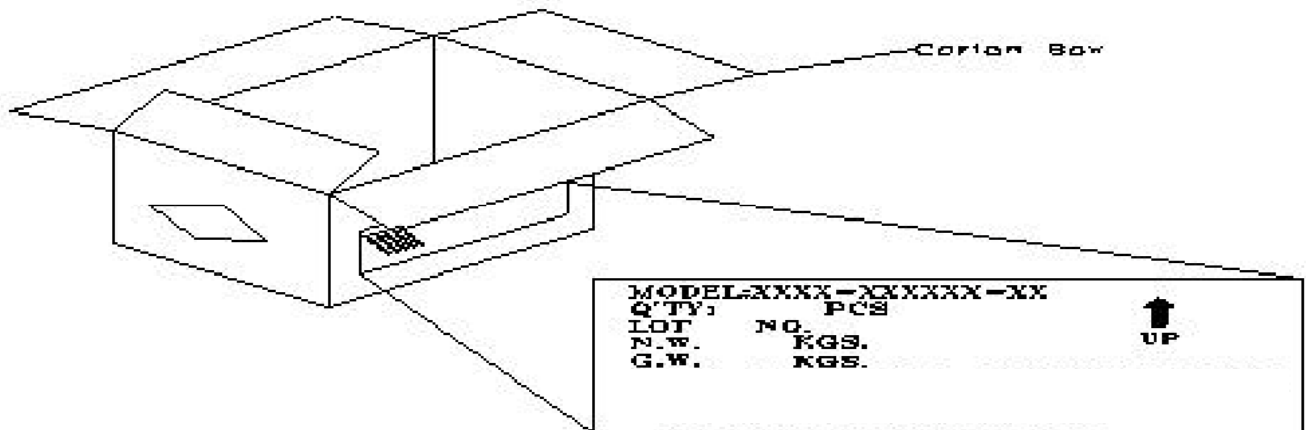

Packing tray must be stacked with alternated direction to each others.
 To tacks packing trays in same direction will cause product damaged.

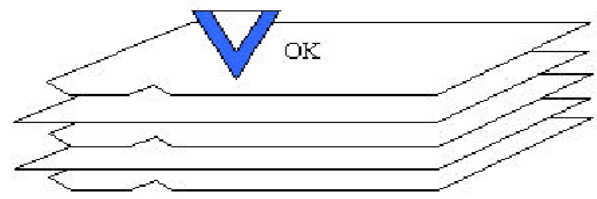
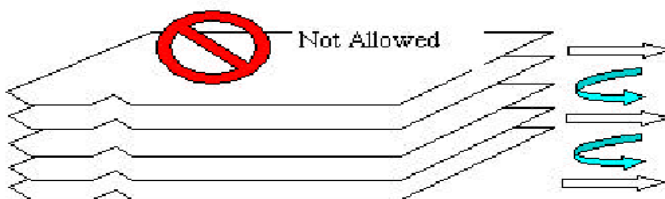
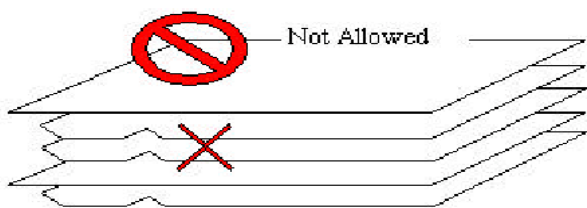

Date : Jan. 23, 2008

TECHNICAL SPECIFICATION

HYES

LCM

HT2801UL

Page 20 of 25

NOTE:

- T.B.D pcs / Tray
- T.B.D Tray / Box
- T.B.D Box / Carton
- T.B.D pcs / Carton

- (1) Be warned, the direction of the tray has to turn it by 180 degree before stack it up. Otherwise, it will be packager's responsibility!!
- (2) Safe Stack : 5 cartons only

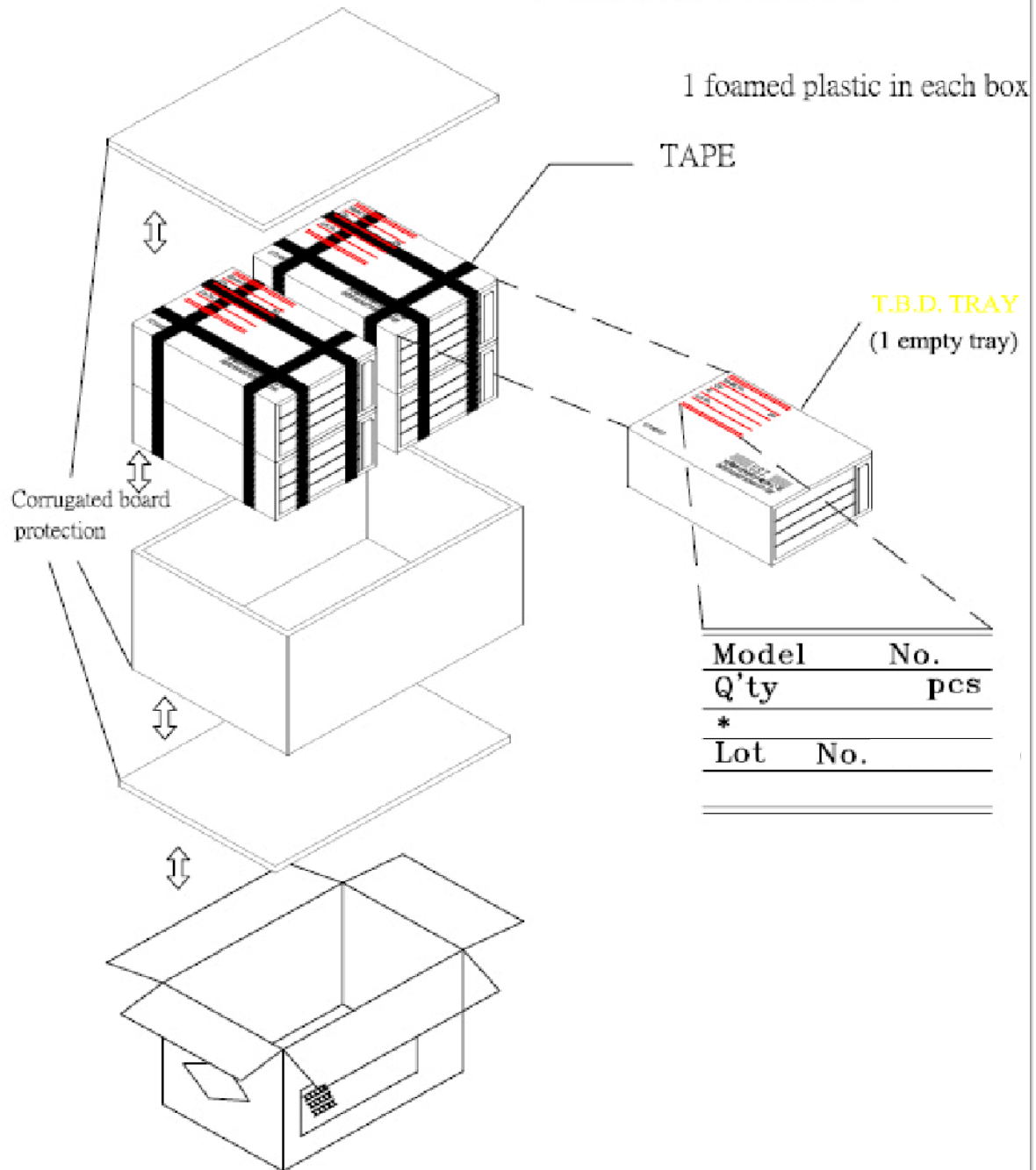

Date : Jan. 23, 2008

TECHNICAL SPECIFICATION

HYES

LCM

HT2801UL

Page 21 of 25

8. INSPECTION STANDARD

8.1. QUALITY :

THE QUALITY OF GOODS SUPPLIED TO PURCHASER SHALL COME UP TO THE FOLLOWING STANDARD.

8.1.1. THE METHOD OF PRESERVING GOODS

AFTER DELIVERY OF GOODS FROM **HYES** TO PURCHASER. PURCHASER SHALL CONTROL THE LCM AT -10 °C ~ 40 °C ,AND IT MIGHT BE DESIRABLE TO KEEP AT THE NORMAL ROOM TEMPERATURE AND HUMIDITY UNTIL INCOMING INSPECTION OR THROWING INTO PROCESS LINE.

8.1.2. INCOMING INSPECTION

(A) THE METHOD OF INSPECTION

IF PURCHASER MAKE AN INCOMING INSPECTION , A SAMPLING PLAN SHALL BE APPLIED ON THE CONDITION THAT QUALITY OF ONE DELIVERY SHALL BE REGARDED AS ONE LOT.

(B) THE STANDARD OF QUALITY

ISO-2859-1 (or MIL-STD-105D), LEVEL II SINGLE PLAN.

CLASS	AQL(%)
CRITICAL	0.4 %
MAJOR	0.65 %
MINOR	1.5 %
TOTAL	1.5 %

EVERY ITEM SHALL BE INSPECTED ACCORDING TO THE CLASS.

(C) MEASURE

IF AS THE RESULT OF ABOVE RECEIVING INSPECTION , A LOT OUT IS DISCOVERED.

PURCHASER SHALL BE INFORM SELLER OF IT WITHIN SEVEN DAYS. BUT FIRST SHIPMENT WITHIN FOURTEEN DAYS.

8.1.3. WARRANTY POLICY

HYES WILL PROVIDE ONE-YEAR WARRANTY FOR THE PRODUCTS ONLY IF UNDER SPECIFICATION OPERATING CONDITIONS. **HYES** WILL REPLACE NEW PRODUCTS FOR THESE DEFECT PRODUCTS WHICH UNDER WARRANTY PERIOD AND BELONG TO THE RESPONSIBILITY OF **HYES**.

8.2. CHECKING CONDITION

8.2.1. CHECKING DIRECTION SHALL BE IN THE 45 DEGREE AREA TO FACE THE SAMPLE.

8.2.2. CHECKER SHALL SEE OVER 30 cm. WITH BARE EYES FAR FROM SAMPLE AND USING 2 PCS. OF 20W FLUORESCENT LAMP.

Date : Jan. 23, 2008

TECHNICAL SPECIFICATION

HYES

LCM

HT2801UL

Page 22 of 25

8.3. INSPECTION PLAN :

CLASS	ITEM	JUDGEMENT	CLASS
PACKING & INDICATE	1. OUTSIDE AND INSIDE PACKAGE	"MODEL NO.", "LOT NO." AND "QUANTITY" SHOULD INDICATE ON THE PACKAGE.	Minor
	2. MODEL MIXED AND QUANTITY	OTHER MODEL MIXED.....REJECTED QUANTITY SHORT OR OVER.....REJECTED	Critical
	3. PRODUCT INDICATION	"MODEL NO." SHOULD INDICATE ON THE PRODUCT	Major
ASSEMBLY	4. DIMENSION, LCD GLASS SCRATCH AND SCRIBE DEFECT.	ACCORDING TO SPECIFICATION OR DRAWING.	Major
APPEARANCE	5. VIEWING AREA	POLARIZER EDGE OR LCD'S SEALING LINE IS VISABLE IN THE VIEWING AREAREJECTED	Minor
	6. BLEMISH - BLACK SPOT - WHITE SPOT IN THE LCD AND LCD GLASS CRACKS	ACCORDING TO STANDARD OF VISUAL INSPECTION (INSIDE VIEWING AREA)	Minor
	7. BLEMISH - BLACK SPOT WHITE SPOT AND SCRTCH ON THE POLARIZER	ACCORDING TO STANDARD OF VISUAL INSPECTION (INSIDE VIEWING AREA)	Minor
	8. BUBBLE IN POLARIZER	ACCORDING TO STANDARD OF VISUAL INSPECTION (INSIDE VIEWING AREA)	Minor
	9. LCD'S RAINBOW COLOR	STRONG DEVIATION COLOR (OR NEWTON RING) OF LCD.....REJECTED. OR ACCORDING TO LIMITED SAMPLE (IF NEEDED, AND INSIDE VIEWING AREA)	Minor
ELECTRICAL	10. ELECTRICAL AND OPTICAL CHARACTERISTICS (CONTRAST - VOP - CHROMATICITY ... ETC)	ACCORDING TO SPECIFICATION OR DRAWING . (INSIDE VIEWING AREA)	Critical
	11. MISSING PATTERN	MISSING DOT - LINE - CHARACTERREJECTED	Critical
	12. SHORT CIRCUIT - WRONG PATTERN DISPLAY	NON DISPLAY - WRONG PATTERN DISPLAY - CURRENT CONSUMPTION OUT OF SPECIFICATION..... REJECTED	Critical
	13. PIN HOLE - PATTERN DEFORMITY	ACCORDING TO STANDARD OF VISUAL INSPECTION	Minor

Date : Jan. 23, 2008

TECHNICAL SPECIFICATION

HYES

LCM

HT2801UL

Page 23 of 25

8.4. STANDARD OF VISUAL INSPECTION

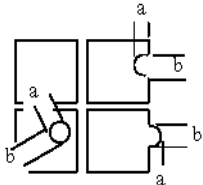
NO.	CLASS	ITEM	JUDGEMENT																									
8.4.1	MINOR	· BLEMISH · BLACK SPOT · WHITE SPOT IN THE LCD. · BLEMISH · BLACK SPOT · WHITE SPOT AND SCRATCH ON THE POLARIZER	(A) ROUND TYPE: unit : mm. <table border="1" style="width: 100%;"> <thead> <tr> <th>DIAMETER (mm.)</th> <th>ACCEPTABLE Q'TY</th> </tr> </thead> <tbody> <tr> <td>$\Phi \leq 0.1$</td> <td>DISREGARD</td> </tr> <tr> <td>$0.1 < \Phi \leq 0.2$</td> <td>2</td> </tr> <tr> <td>$0.2 < \Phi \leq 0.25$</td> <td>1</td> </tr> <tr> <td>$0.25 < \Phi$</td> <td>0</td> </tr> </tbody> </table> NOTE: $\Phi = (\text{LENGTH} + \text{WIDTH}) / 2$ (B) LINER TYPE: unit : mm. <table border="1" style="width: 100%;"> <thead> <tr> <th>LENGTH</th> <th>WIDTH</th> <th>ACCEPTABLE Q'TY</th> </tr> </thead> <tbody> <tr> <td>-----</td> <td>$W \leq 0.03$</td> <td>DISREGARD</td> </tr> <tr> <td>$L \leq 5.0$</td> <td>$0.03 < W \leq 0.05$</td> <td>3</td> </tr> <tr> <td>$L \leq 5.0$</td> <td>$0.05 < W \leq 0.07$</td> <td>1</td> </tr> <tr> <td>-----</td> <td>$0.07 < W$</td> <td>FOLLOW ROUND TYPE</td> </tr> </tbody> </table>	DIAMETER (mm.)	ACCEPTABLE Q'TY	$\Phi \leq 0.1$	DISREGARD	$0.1 < \Phi \leq 0.2$	2	$0.2 < \Phi \leq 0.25$	1	$0.25 < \Phi$	0	LENGTH	WIDTH	ACCEPTABLE Q'TY	-----	$W \leq 0.03$	DISREGARD	$L \leq 5.0$	$0.03 < W \leq 0.05$	3	$L \leq 5.0$	$0.05 < W \leq 0.07$	1	-----	$0.07 < W$	FOLLOW ROUND TYPE
DIAMETER (mm.)	ACCEPTABLE Q'TY																											
$\Phi \leq 0.1$	DISREGARD																											
$0.1 < \Phi \leq 0.2$	2																											
$0.2 < \Phi \leq 0.25$	1																											
$0.25 < \Phi$	0																											
LENGTH	WIDTH	ACCEPTABLE Q'TY																										
-----	$W \leq 0.03$	DISREGARD																										
$L \leq 5.0$	$0.03 < W \leq 0.05$	3																										
$L \leq 5.0$	$0.05 < W \leq 0.07$	1																										
-----	$0.07 < W$	FOLLOW ROUND TYPE																										
8.4.2	MINOR	BUBBLE IN POLARIZER	unit : mm. <table border="1" style="width: 100%;"> <thead> <tr> <th>DIAMETER</th> <th>ACCEPTABLE Q'TY</th> </tr> </thead> <tbody> <tr> <td>$\Phi \leq 0.15$</td> <td>DISREGARD</td> </tr> <tr> <td>$0.15 < \Phi \leq 0.5$</td> <td>2</td> </tr> <tr> <td>$0.5 < \Phi$</td> <td>0</td> </tr> </tbody> </table>	DIAMETER	ACCEPTABLE Q'TY	$\Phi \leq 0.15$	DISREGARD	$0.15 < \Phi \leq 0.5$	2	$0.5 < \Phi$	0																	
DIAMETER	ACCEPTABLE Q'TY																											
$\Phi \leq 0.15$	DISREGARD																											
$0.15 < \Phi \leq 0.5$	2																											
$0.5 < \Phi$	0																											
8.4.3	MINOR	PIN HOLE · PATTERN DEFORMITY	unit : mm.  <table border="1" style="width: 100%;"> <thead> <tr> <th>DIAMETER</th> <th>ACC. Q'TY</th> </tr> </thead> <tbody> <tr> <td>$\Phi \leq 0.1$</td> <td>DISREGARD</td> </tr> <tr> <td>$0.1 < \Phi \leq 0.25$</td> <td>3</td> </tr> <tr> <td>$0.25 < \Phi$</td> <td>0</td> </tr> </tbody> </table> <p>$\Phi = (a+b)/2$</p>	DIAMETER	ACC. Q'TY	$\Phi \leq 0.1$	DISREGARD	$0.1 < \Phi \leq 0.25$	3	$0.25 < \Phi$	0																	
DIAMETER	ACC. Q'TY																											
$\Phi \leq 0.1$	DISREGARD																											
$0.1 < \Phi \leq 0.25$	3																											
$0.25 < \Phi$	0																											

Date : Jan. 23, 2008

TECHNICAL SPECIFICATION

HYES

LCM

HT2801UL

Page 24 of 25

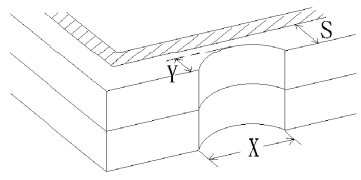
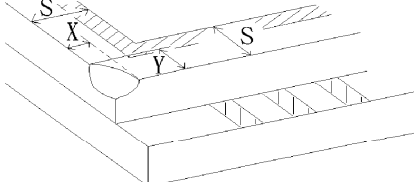
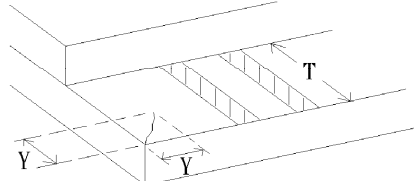
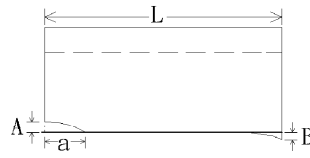
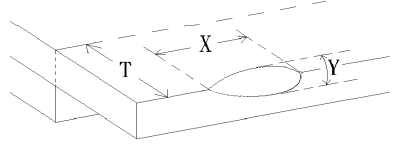
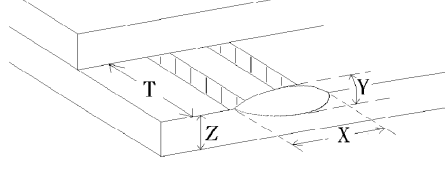
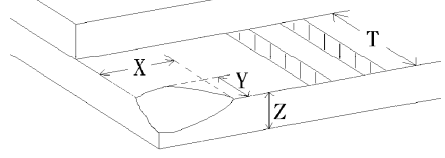
NO.	CLASS	ITEM	JUDGEMENT
8.4.4	MINOR	CHIPPING	 $Y > S$ REJ.
8.4.5	MINOR	CHIPPING	 $X \text{ or } Y > S$ REJ.
8.4.6	MAJOR	GLASS CRACK	 $Y > (1/2) T$ REJ.
8.4.7	MAJOR	SCRIBE DEFECT	 <ol style="list-style-type: none"> $a > L/3$, $A > 1.5\text{mm}$. REJ. B : ACCORDING TO DIMENSION
8.4.8	MINOR	CHIPPING (ON THE TERMINAL AREA)	 $\Phi = (x+y)/2 > 2.5 \text{ mm}$ REJ.
8.4.9	MINOR	CHIPPING (ON THE TERMINAL SURFACE)	 $Y > (1/3) T$ REJ.
8.4.10	MINOR	CHIPPING	 $Y > T$ REJ.

Date : Jan. 23, 2008

TECHNICAL SPECIFICATION



LCM

HT2801UL

Page 25 of 25