

APPROVAL

PART NO.	DESCRIPTION	REMARKS
HT3503L	LCD MODULE (320 x RGB x 240)	* This is ROHS compliant

CUSTOMER APPLICATION P/N	
APPROVED BY	
DATE	

PLEASE KINDLY FIND AND APPROVE THE SPECIFICATIONS INSERTED
HEREIN AND RETURN ONE COPY HERE OF WITH YOUR SIGNATURE OF APPROVAL.

PERPARED BY	CHECKED BY	CONFIRMED BY



HYES Optoelectronics, Inc.

2000 Wyatt Drive Suite 6
Santa Clara, CA 95054 USA

CONTENTS:

No.	Item
1	BASIC SPECIFICATION 1.1 Mechanical Specification 1.2 Display Specification 1.3 Outline Dimension 1.4 Block Diagram 1.5 Interface Pin
2	ELECTRICAL CHARACTERISTICS 2.1 Absolute Maximum Ratings 2.2 DC Characteristics 2.2.1 Back-light 2.3 AC Characteristics
3	OPTICAL CHARACTERISTICS 3.1 Condition 3.2 Definition of Optical Characteristics
4	RELIABILITY
5	PRODUCT HANDLING AND APPLICATION
6	DATECODE
7	PACKING & LOTNO
8	INSPECTION STANDARD

Date : Feb. 04, 2007

TECHNICAL SPECIFICATION

The logo for HYES, consisting of the word "HYES" in white capital letters on a dark orange rectangular background.

LCM

HT3503L

Page 2 of 33

1. BASIC SPECIFICATION

1.1 Mechanical specifications

Items	Nominal Dimension	Unit
Active screen size	3.5" diagonal	-
Dot Matrix	320*RGB*240	dots
Module Size (W x H x T)	76.9 x 63.9 x 3.2	mm.
Active Area (W x H)	70.08 x 52.56	mm.
Dot Pitch (W x H)	0.219 x 0.219	mm.
Color depth	262K	color
Interface	8-bits serial/24-bits parallel RGB / CCIR601/656	-
Driving IC Package	COG	-

1.2 Display specification

Display	Descriptions	Note
LCD Type	a-Si TFT	-
LCD Mode	TN / Normal white	-
Polarizer Mode	Transmissive	-
Polarizer Surface	Normal	-
Pixel arrangement	RGB-stripe	-
Backlight Type	LED	-
Viewing Direction	6 O'clock Direction	-

* Color tone is slightly changed by temperature and driving voltage.

Date : Feb. 04, 2007

TECHNICAL SPECIFICATION

 HYES

LCM

HT3503L

Page 3 of 33

1.3 Outline Dimension

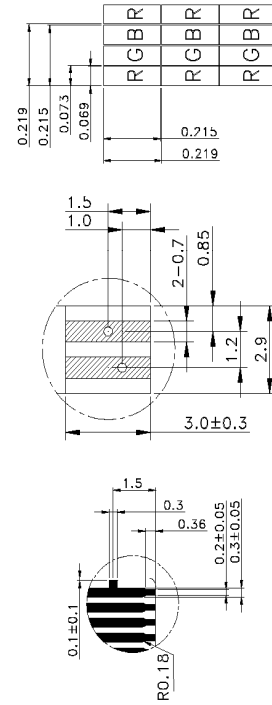
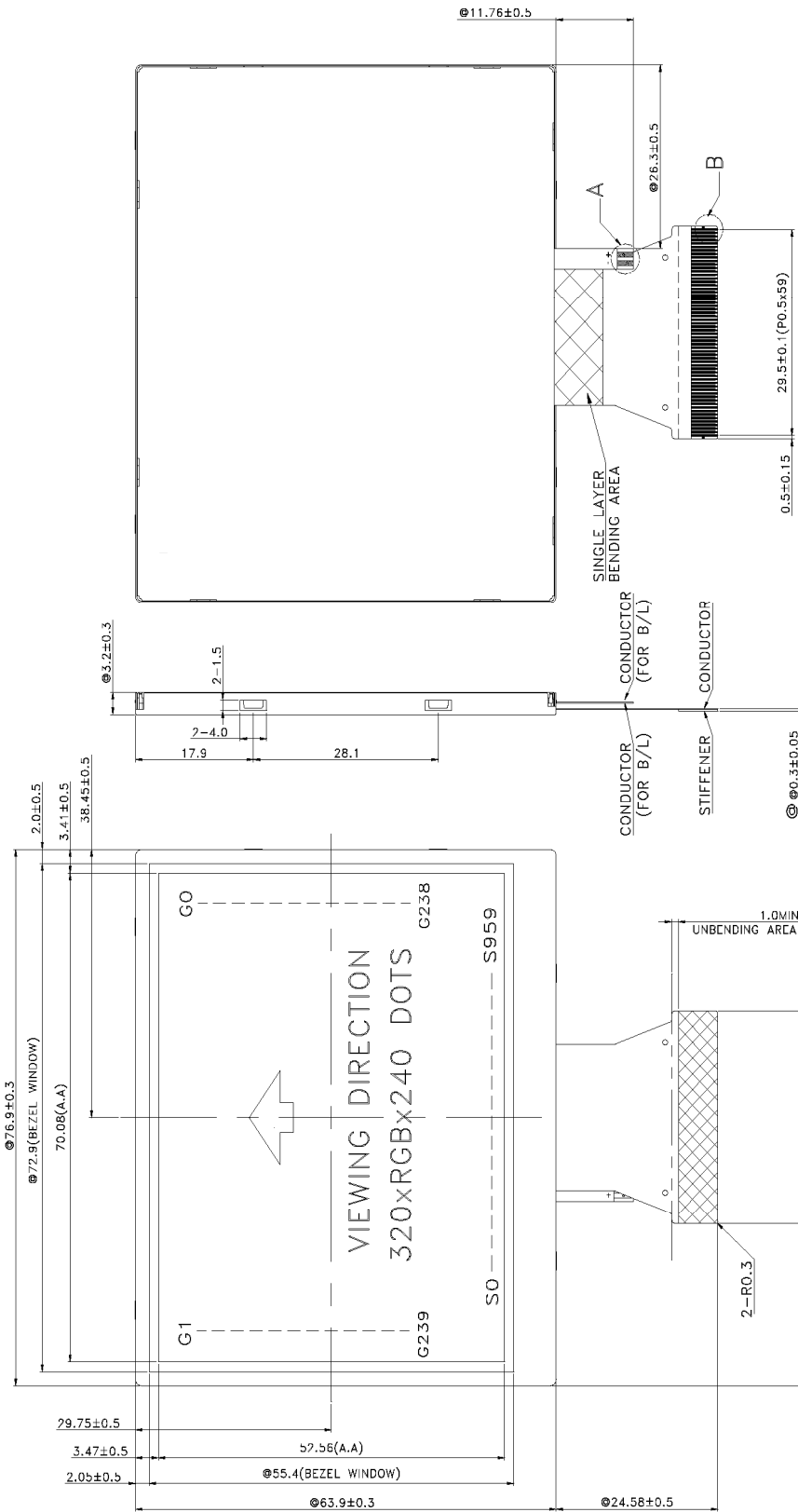

- NOTE :
1. LCD:TFT TRANSMISSIVE MODE,NORMAL WHITE
 2. VIEWING DIRECTION : 6 O'CLOCK
 3. Top : -20~70°C , Tst : -30~80°C
 4. DRIVER IC : HX8238-A
 5. "Ø" KEY DIMENSION.
 6. TOLERANCE FOR NOT ASSIGNED:±0.2
 7. LED COLOR : WHITE , 6PCS DICE
 8. CONSTANT CURRENT IF=20.0mA ; VLED=20.4V(Typ)
- THE MINIMUM BENDING RADIUS (INNER) OF THE FPC IS 0.5mm.

DETAIL B DETAIL A DOTS DETAIL

Date : Feb. 04, 2007

TECHNICAL SPECIFICATION



LCM

HT3503L

Page 4 of 33

1.5 Interface pin :

Pin No.	Pin Name	I/O	Description
1	VSS	P	System ground pin of the IC. - Connect to system ground
2	POL	O	Polarity signal to monitor VCOM signal. - Leave it OPEN when not used.
3	RES	I	System reset pin. Internal pull high.
4	CSB	I	Chip select pin of serial interface. Internal pull high. - Leave it OPEN when not used.
5	SCK	I	Clock pin of serial interface. Internal pull high. - Leave it OPEN when not used.
6	SDI	I	Data input pin in serial mode. Internal pull high. - Leave it OPEN when not used.
7~30	BB [0:7] GG [0:7] RR [0:7]	I	Graphic Data Input Pins. Internal pull low. - RR [0:7]: Red Data - 8-bits - GG [0:7]: Green Data - 8-bits - BB [0:7]: Blue Data - 8-bits For 8 bit interface, only RR[0:7] are used. For unused pins, please connect to VSS or floating.
31	DEN	I	Display enable pin from controller. Connect to VCI or floating if not used.
32	HSYNC	I	Line synchronization signal. Internal pull high. - Fixed to VCI or floating if not used.
33	VSYNC	I	Frame synchronization signal. Internal pull high. - Fixed to VCI or floating if not used.
34	DOTCLK	I	Dot-clock signal and oscillator source.
35	SDO	O	Data output pin in serial mode. - Leave it OPEN when not used.
36	TB	I	Input pin to select the Gate driver scan direction. - Connect to VSS for Gate scan from G239 to G0 (reverse scan) - Connect to VCI for Gate scan from G0 to G239 (normal scan)

Date : Feb. 04, 2007

TECHNICAL SPECIFICATION

HYES

LCM

HT3503L

Page 6 of 33

Pin No.	Pin Name	I/O	Description
37	RL	I	Input pin to select the Source driver data shift direction. - Connect to VCI for display first RGB data at \$0-\$2. - Connect to VSS for display first RGB data at \$959-\$957.
38	VCIM	O	Negative voltage of VCI. - Connect a capacitor for stabilization.
39	C1P	I	Connect a capacitor to C1N.
40	C1N	I	Connect a capacitor to C1P.
41	VLCD63	O	Internal generated power for source driver. - Connect a capacitor for stabilization.
42	VCIX2J	P	This is the power supply used by on chip analog blocks and VGH/VGL. -Connect to VCIX2.
43	VCIX2	O	Equals to 2 x VCI. Connect a capacitor for stabilization.
44	CYN	I	Connect a capacitor to CYP.
45	CYP	I	Connect a capacitor to CYN.
46	CXN	I	Connect a capacitor to CXP.
47	CXP	I	Connect a capacitor to CXN.
48	VCI	P	Power Supply for Analog Circuits.
49	VDD	P	Power Supply for Logic Circuits. - Connect a capacitor for stabilization.
50	CN	I	Connect a capacitor to CP.
51	CP	I	Connect a capacitor to CN.
52	VGL	O	A negative power output pin for gate driver. - Connect a capacitor for stabilization.
53	C2N	I	Connect a capacitor to C2P.
54	C2P	I	Connect a capacitor to C2N.
55	C3N	I	Connect a capacitor to C3P.

Date : Feb. 04, 2007

TECHNICAL SPECIFICATION

HYES

LCM

HT3503L

Page 7 of 33

Pin No.	Pin Name	I/O	Description
56	C3P	I	Connect a capacitor to C3N.
57	VGH	O	A positive power output pin for gate driver. - Connect a capacitor for stabilization.
58	VCOML	O	This pin indicates a LOW level of VCOM generated in driving the VCOM alternation. - Connect a capacitor for stabilization.
59	VCOMH	O	This pin indicates a HIGH level of VCOM generated in driving the VCOM alternation. - Connect a capacitor for stabilization.
60	VCOM	O	A power supply for the TFT-display common electrode. - Leave it OPEN.

Backlight pin:

Pin No.	Pin Name	I/O	Description
1	K	P	Backlight LED' s cathode.
2	A	P	Backlight LED' s anode.

2. ELECTRICAL CHARACTERISTICS

2.1 Absolute Maximum Ratings

Items	Symbol	Min.	Max.	Unit
Input voltage	V _{CI}	V _{SS} -0.3	5.0	V
Operate temperature range	T _{OP}	-20	70	°C
Storage temperature range	T _{sr}	-30	80	°C

Date : Feb. 04, 2007

TECHNICAL SPECIFICATION

HYES

LCM

HT3503L

Page 8 of 33

2.2 DC Characteristics

Items	Symbol	Min.	Typ.	Max.	Unit	Condition
Power supply voltage	VCI	2.5	3.3	3.6	V	
Current consumption	IVCI	-	-	36	mA	NOTE
Dot Clock	DCK	-	7.5	10	MHz	
Serial Clock	XSCK	-	19.5	30	MHz	

NOTE : The method to illuminate the LCD panel is using the 2-4-7 command under the measuring condition.

Measuring Condition :

Standard Value MAX.

Ta = 25°C

Vci = 3.3V

Dot Clock = 7.5MHz

Display Patten = Checkered pattern



0 gray black pattern

2-2.1 Back-light Characteristics

Parameter	Symbol	Min	Typ	Max	Unit	Test Condition	Note
Supply Current	If	-	20	-	mA	Ta=25°C	-
Supply Voltage	VF	18.6	20.4	22.2	V	Ta=25°C	-
Half-Life Time	Lf	-	10000	-	hrs	Ta=25°C	-

Note: The " Half-Life Time "is defined as the module brightness decrease to 50% original brightness.

Date : Feb. 04, 2007

TECHNICAL SPECIFICATION

HYES

LCM

HT3503L

Page 9 of 33

2.3 AC Characteristics

2-3-1 8-bits serial/24-bits parallel RGB

AC Characteristics

(Unless otherwise specified, Voltage Referenced to V_{SS},

T_A = 25°C)

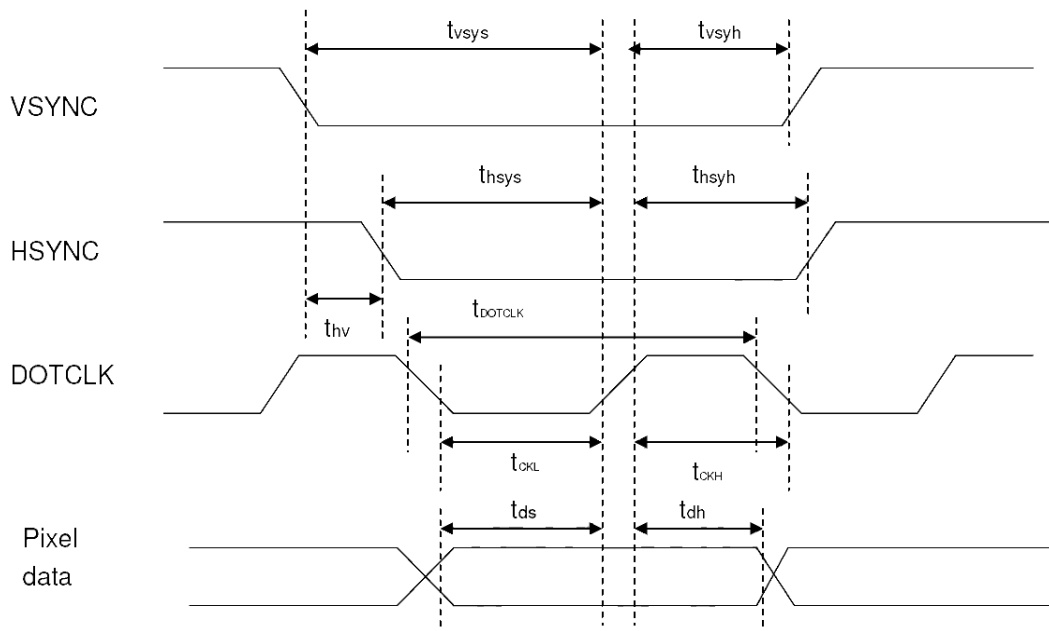

Figure 14. 1 Pixel Timing

Characteristics	Symbol	Min.		Typ.		Max.		Unit
		24bit	8bit	24bit	8bit	24bit	8bit	
DOTCLK Frequency	f _{DOTCLK}	-		7.5	19.5	10	30	MHz
DOTCLK Period	t _{DOTCLK}	100	33.3	154	61.3	-	-	ns
Vertical Sync Setup Time	t _{sys}	20	10	-	-	-	-	ns
Vertical Sync Hold Time	t _{syh}	20	10	-	-	-	-	ns
Horizontal Sync Setup Time	t _{hsys}	20	10	-	-	-	-	ns
Horizontal Sync Hold Time	t _{hsyh}	20	10	-	-	-	-	ns
Phase difference of Sync Signal Falling Edge	t _{hv}	1		-		240		t _{DOTCLK}
DOTCLK Low Period	t _{CKL}	50	15	-	-	-	-	ns
DOTCLK High Period	t _{CKH}	50	15	-	-	-	-	ns
Data Setup Time	t _{ds}	12	8	-	-	-	-	ns
Data hold Time	t _{dh}	12	8	-	-	-	-	ns
Reset pulse width	t _{RES}	10		-		-		us

Note: External clock source must be provided to DOTCLK pin of HX8238-A. The driver will not operate if absent of the clocking signal.

Date : Feb. 04, 2007

TECHNICAL SPECIFICATION

HYES

LCM

HT3503L

Page 10 of 33

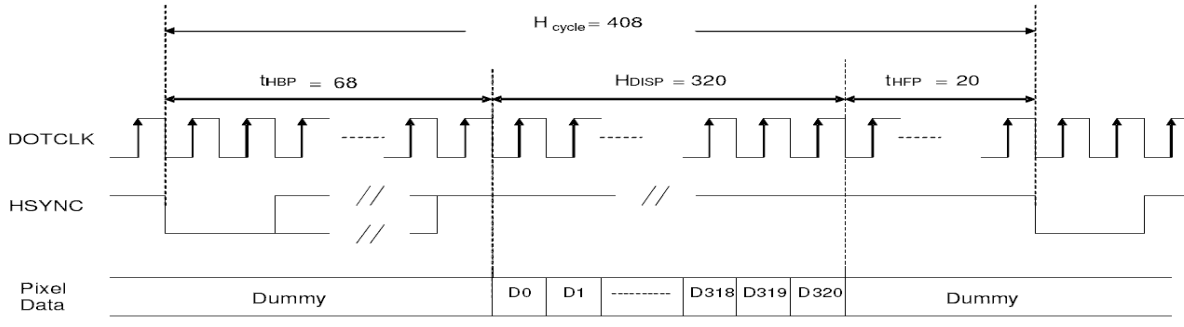

a) Horizontal Data Transaction Timing

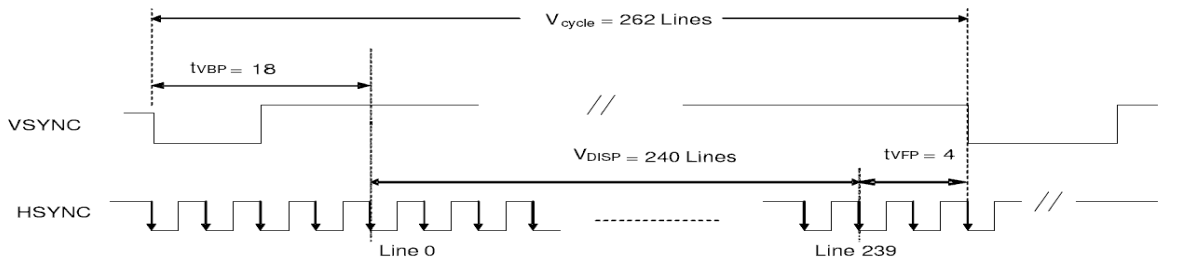

b) Vertical Data Transaction Timing

Figure 14. 2 Data transaction timing in parallel RGB (24 bit) interface (SYNC mode)

Characteristics	Symbol	Min		Typ		Max		Unit
		24bit	8 bit	24bit	8 bit	24bit	8 bit	
DOTCLK Frequency	fDOTCLK	-	-	7.5	19.5	10	30	MHz
DOTCLK Period	tDOTCLK	100	33.3	154	51.3	-	-	ns
Horizontal Frequency (Line)	fH	-		18.37		22.35		KHz
Vertical Frequency (Refresh)	fV	-		70		90		Hz
Horizontal Back Porch	thBP	-	-	68	204	-	-	tDOTCLK
Horizontal Front Porch	thFP	-	-	20	60	-	-	tDOTCLK
Horizontal Data Start Point	thBP	-	-	68	204	-	-	tDOTCLK
Horizontal Blanking Period	thBP + thFP	-	-	88	264	-	-	tDOTCLK
Horizontal Display Area	HDISP	-	-	320	960	-	-	tDOTCLK
Horizontal Cycle	Hcycle	-	-	408	1224	450	1350	tDOTCLK
Vertical Back Porch	tvBP	-		18		-		Lines
Vertical Front Porch	tvFP	-		4		-		Lines
Vertical Data Start Point	tvBP	-		18		-		Lines
Vertical Blanking Period	tvBP + tvFP	-		22		-		Lines
Vertical Display Area	NTSC			240				Lines
	PAL			280(PALM=0)				
				288(PALM=1)				
Vertical Cycle	NTSC			262				Lines
	PAL			313		350		

Table 14. 2 Data Transaction Timing in Normal Operating Mode

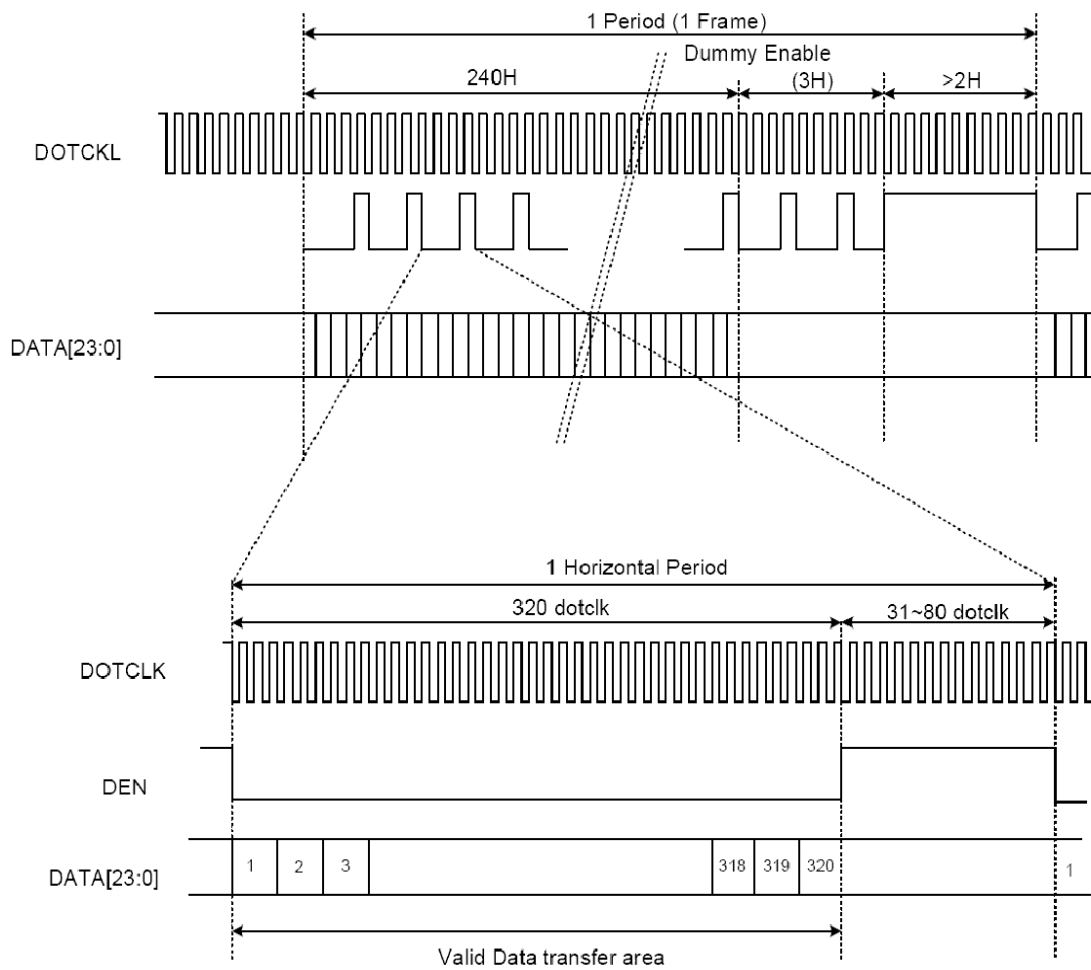
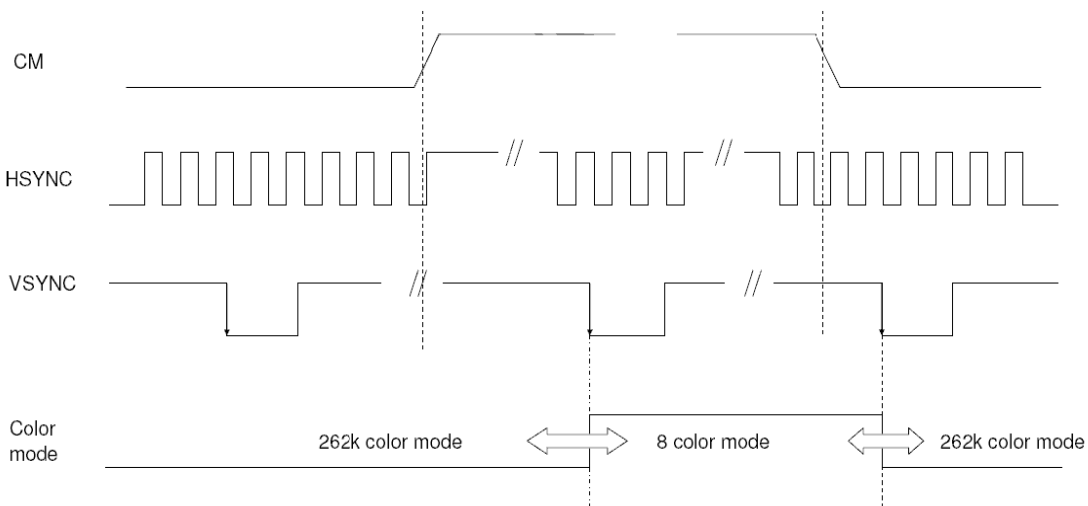

Figure 14. 3 Signal timing in DE mode



Note: The color mode conversion starts at the first falling edge of VSYNC after stage change of CM.

Figure 14. 4 Color mode conversion timing

2-3-2 CCIR601 Timing

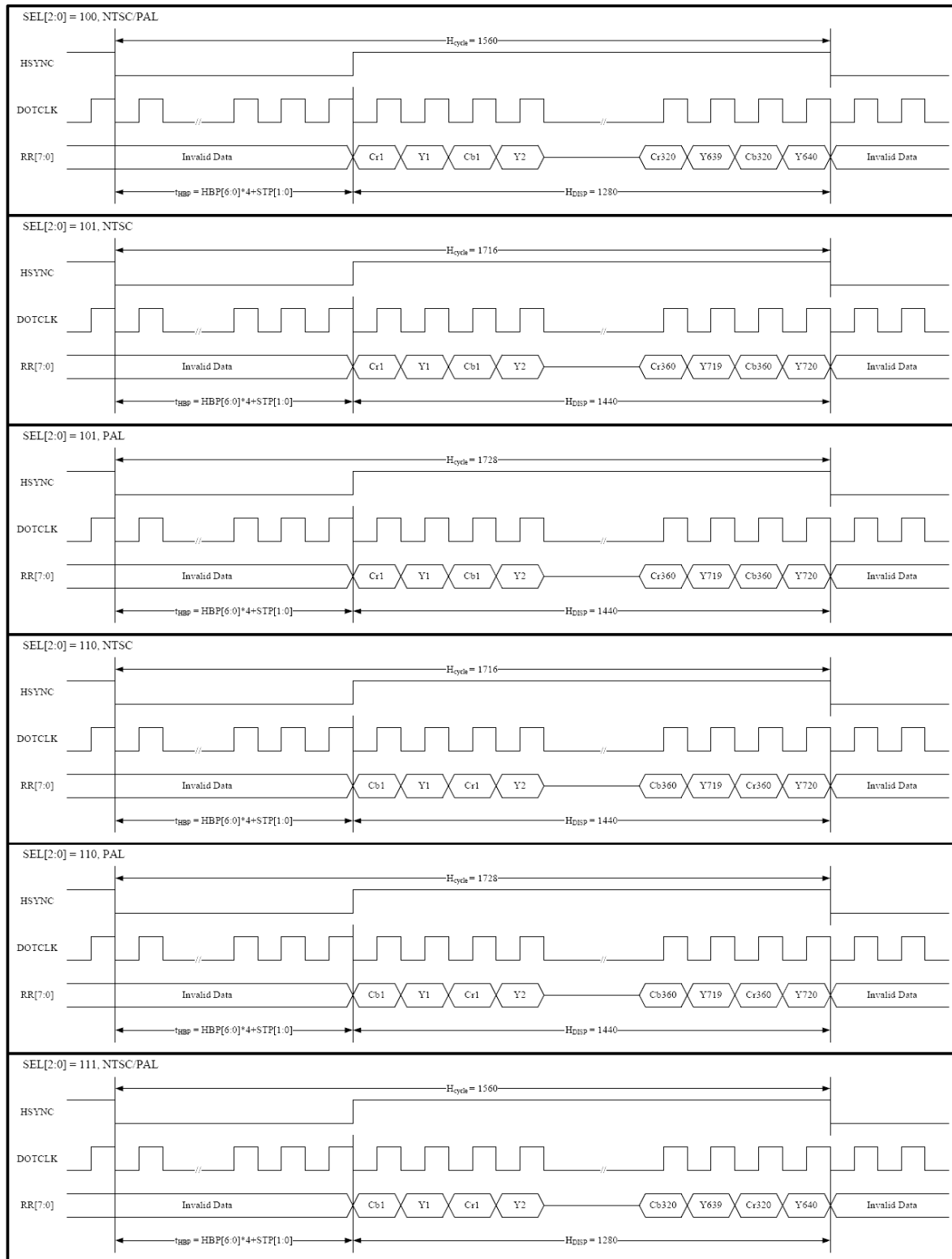

Figure 14. 5 CCIR601 horizontal timing

Date : Feb. 04, 2007

TECHNICAL SPECIFICATION

HYES

LCM

HT3503L

Page 13 of 33

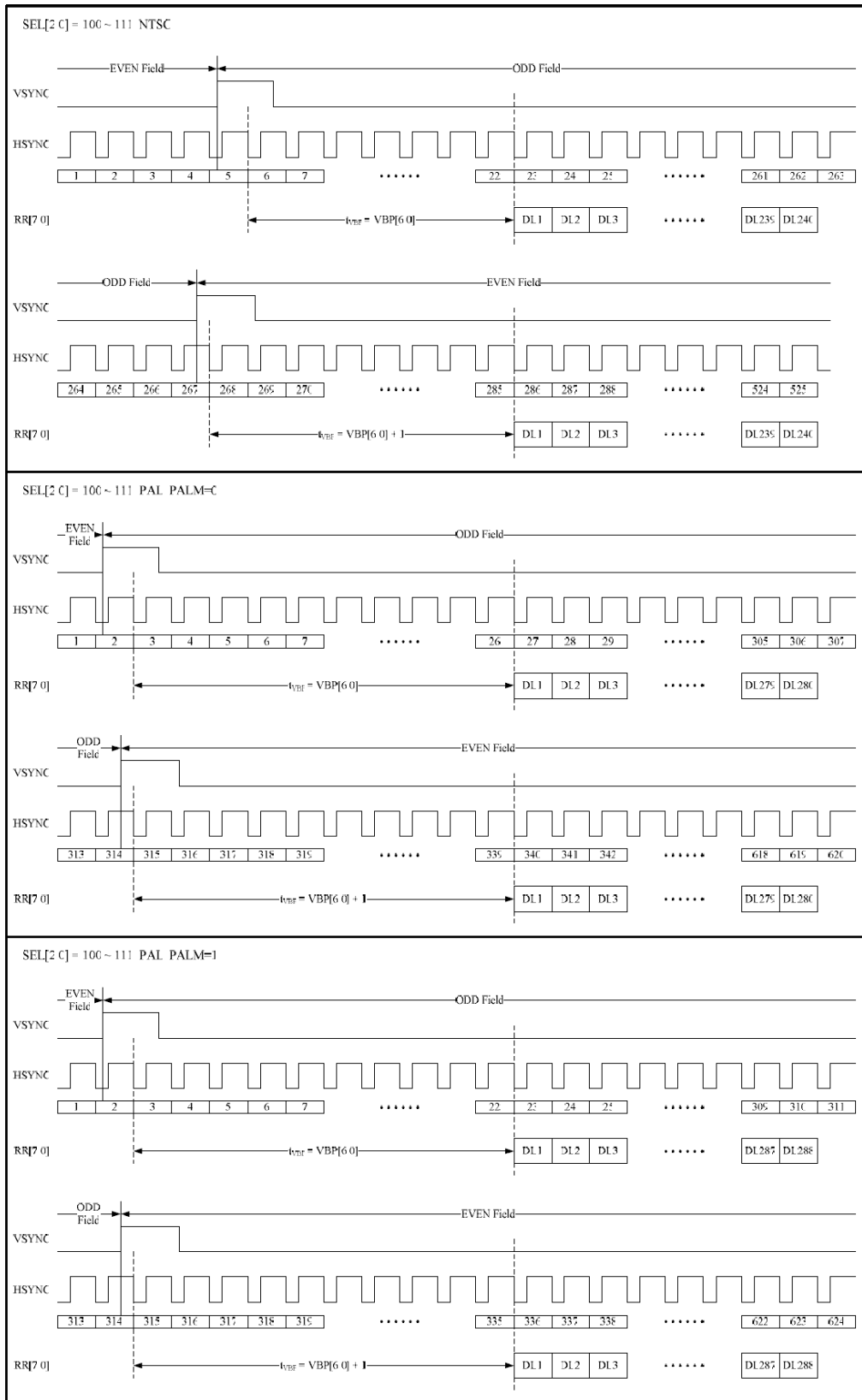

Figure 14. 6 CCIR601 vertical timing

Date : Feb. 04, 2007

TECHNICAL SPECIFICATION

HYES

LCM

HT3503L

Page 14 of 33

2-3-3 CCIR656 Timing

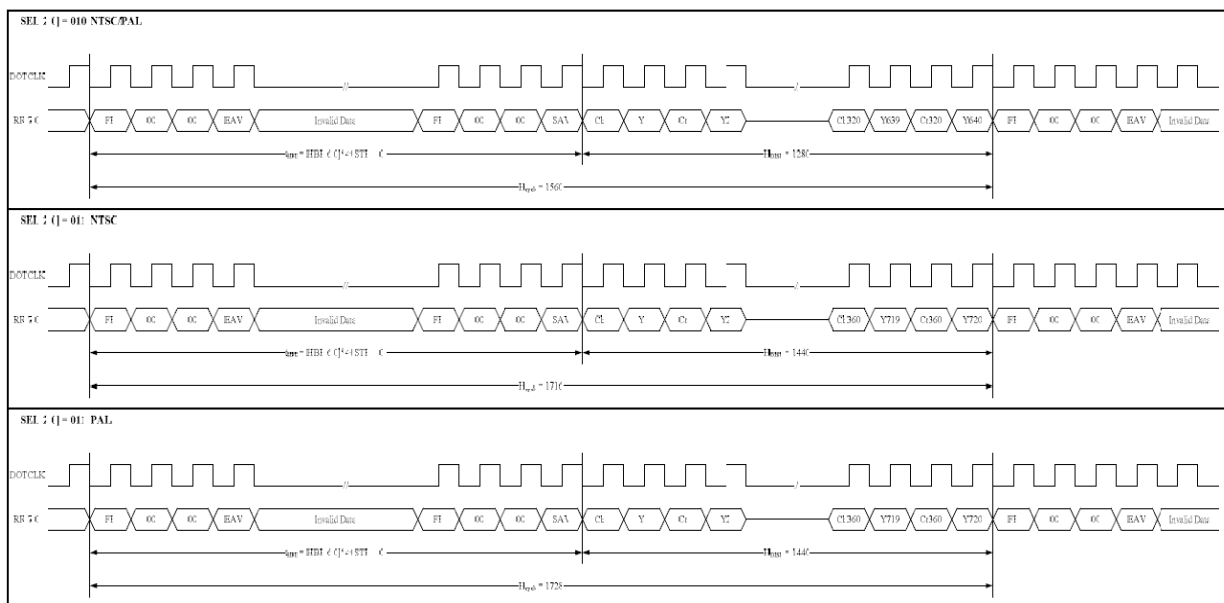

Figure 14. 7 CCIR656 horizontal timing

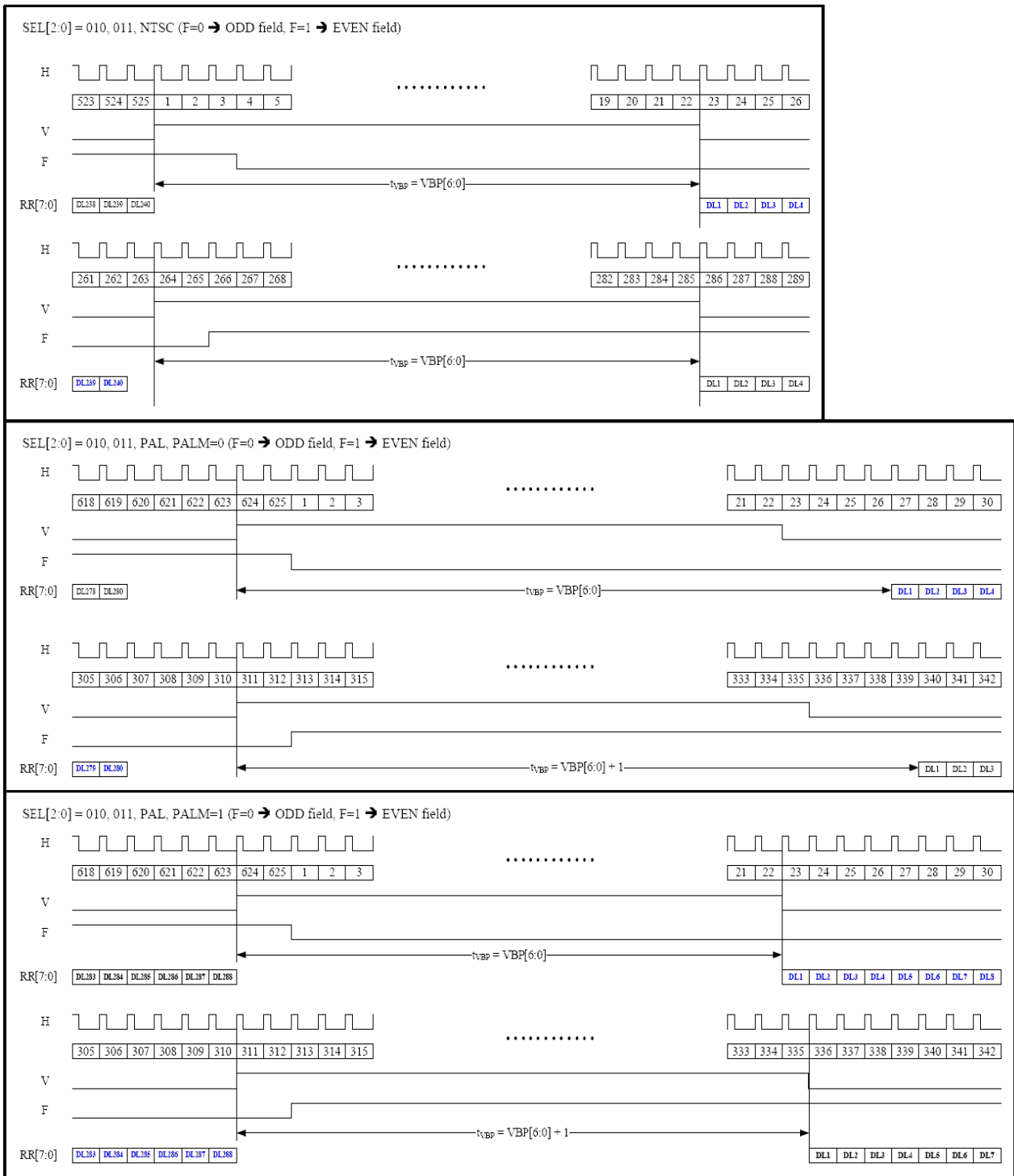

Figure 14. 8 CCIR656 vertical timing

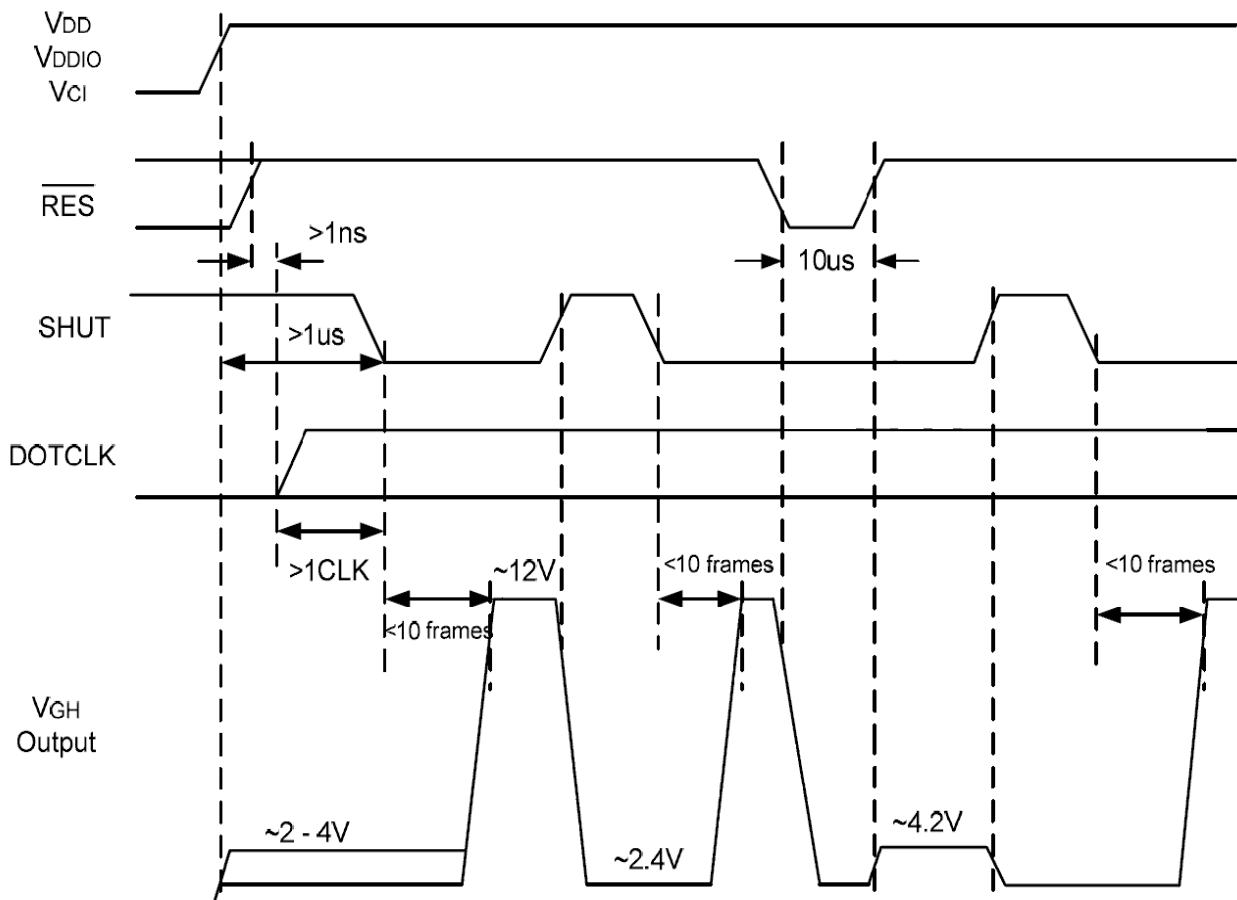

Figure 14. 9 VGH Output Against SHUT & RES

- Note:**
- (1) The minimum cycle time of SHUT is $10 + 2$ frames.
 - (2) DOTCLK must be provided for boosting of VGH. The above timing diagram assumed voltages and DOTCLK are continuous supplied after power on.
 - (3) VGH and VGL will be forced to VSS at the low stage of RESB.
 - (4) The minimum pulse width of RESB is $10\mu\text{s}$.

2-3-4 Power Up Sequence

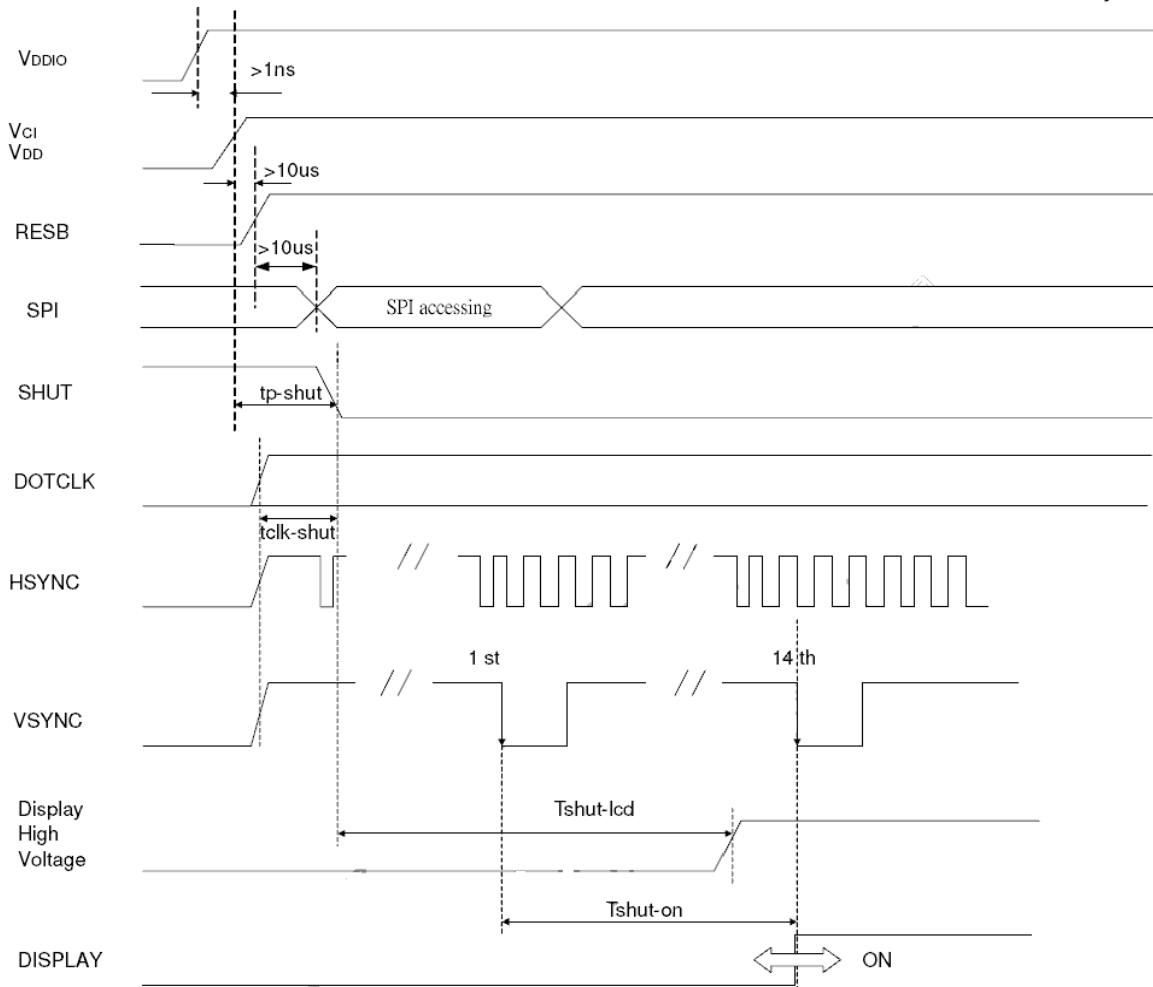

Figure 14. 10 Power Up Sequence

Characteristics	Symbol	Min	Typ	Max	Units
VDDD / VDDIO on to falling edge of SHUT	tp-shut	1	-	-	us
DOTCLK	tclk-shut	1	-	-	clk
Falling edge of SHUT to LCD power on	tshut-lcd	-	-	128	ms
Falling edge of SHUT to display start -1 line: 408 clk -1 frame: 262 line -DOTCLK = 7.5MHz	tshut-on	-	-	14	frame
		-	166	232.4	ms

Note: It is necessary to input DOTCLK before the falling edge of SHUT.

Display starts at 10th falling edge of VSTNC after the falling edge of SHUT.

Table 14.3 Power Up Sequence

Date : Feb. 04, 2007

TECHNICAL SPECIFICATION

HYES

LCM

HT3503L

Page 18 of 33

2-3-5 Power Down Sequence

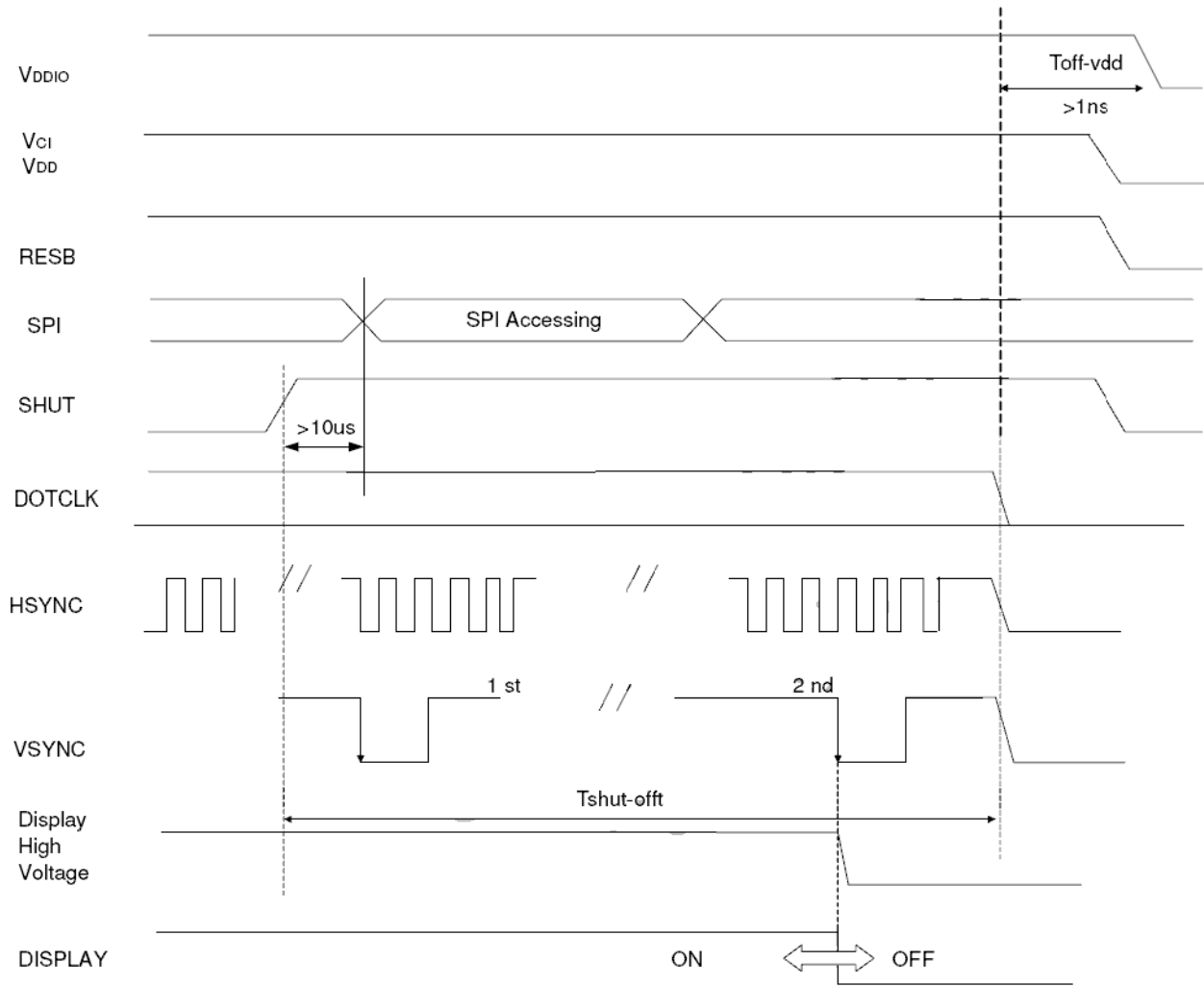

Figure 14. 11 Power Down Sequence

Characteristics	Symbol	Min	Typ	Max	Uni
Rising edge of SHUT to display off	tshut-off	2	-	-	frame
-1 line: 408 clk -1 frame: 262 line -DOTCLK = 7.5MHz		33.4	-	-	ms
Input-signal-off to VDDD / VDDIO off	toff-vdd	1	-	-	us

Note: DOTCLK must be maintained at least 2 frames after the rising edge of SHUT.

Display become off at the 2nd falling edge of VSTNC after the falling edge of SHUT.

If RESET signal is necessary for power down, provide it after the 2-frames-cycle of the SHUT period.

Table 14. 4 Power Down Sequence

Date : Feb. 04, 2007		TECHNICAL SPECIFICATION	
	LCM	HT3503L	Page 19 of 33

2-3-6 SPI Timing

First Transmission (Register)

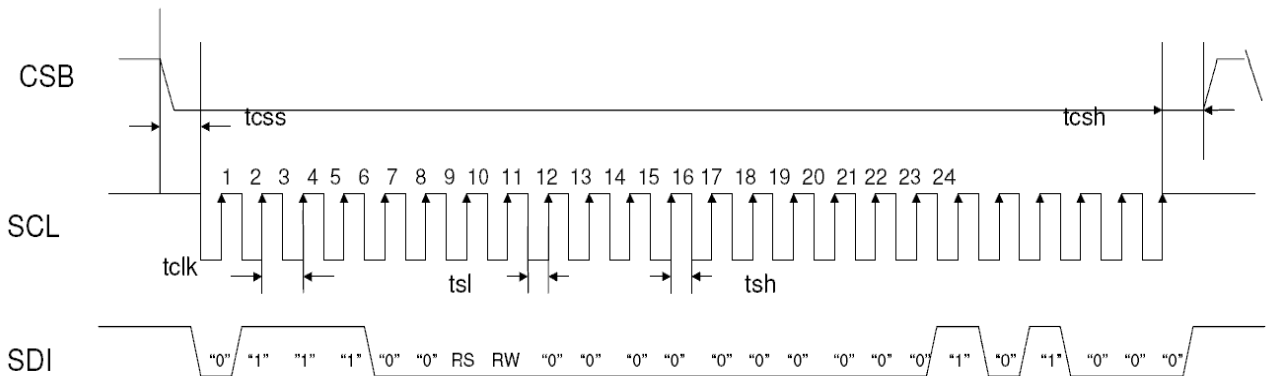

Second Transmission (Data)

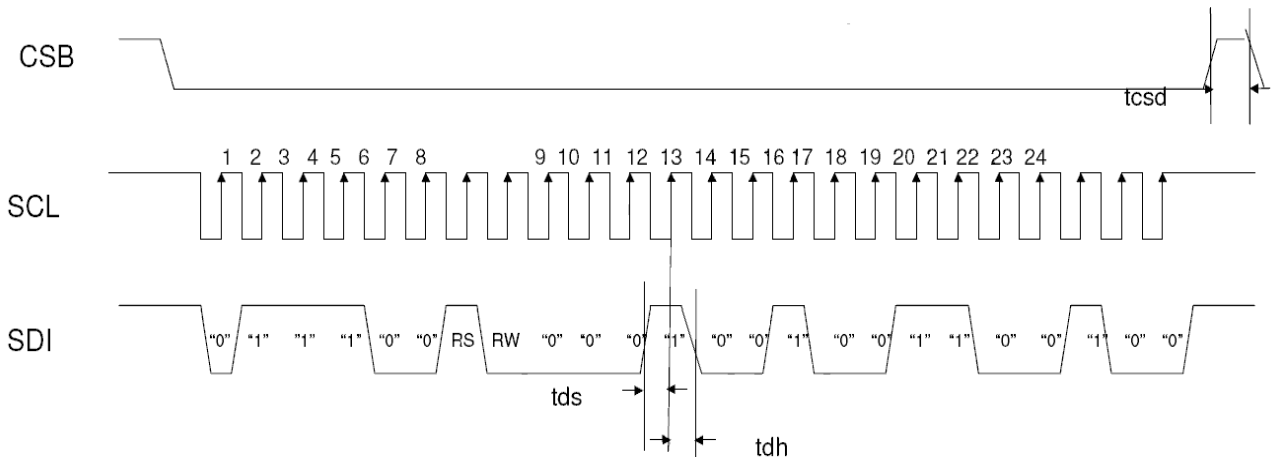

Note: The example transmit "0x1264h" to register R28h.
SPID connected to VSS.

Figure 14. 12 SPI interface Timing Diagram & Transaction Example

Characteristics	Symbol	Min	Typ	Max	Unit
Serial Clock Frequency	fclk	-	-	20	MHz
Serial Clock Cycle Time	tclk	50	-	-	ns
Clock Low Width	tsl	25	-	-	ns
Clock High Width	tsh	25	-	-	ns
Chip Select Setup Time	tcss	0	-	-	ns
Chip Select Hold Time	tcsh	10	-	-	ns
Chip Select High Delay Time	tcsh	20	-	-	ns
Data Setup Time	tds	5	-	-	ns
Data Hold Time	tdh	10	-	-	ns

Table 14. 5 SPI Timing

Date : Feb. 04, 2007

TECHNICAL SPECIFICATION

HYES

LCM

HT3503L

Page 20 of 33

2-3-7 Command

LCD_Initial_HX-8238:

COMMAND	CODE	DESCRIPTION
R02H	0200	LCD-Driving-Waveform Control
R03H	6364	Power control 1
R04H	0440	Input Data and Color Filter Control
R0DH	3221	Power Control 2
R0EH	3100	Power Control 3

Adjust the Gamma Curve:

COMMAND	CODE	DESCRIPTION
R30H	0000	Gamma Control 1
R31H	0407	Gamma Control 1
R32H	0202	Gamma Control 1
R33H	0000	Gamma Control 1
R34H	0505	Gamma Control 1
R36H	0707	Gamma Control 1
R37H	0000	Gamma Control 1
R3AH	0904	Gamma Control 2
R3BH	0904	Gamma Control 2

Date : Feb. 04, 2007

TECHNICAL SPECIFICATION

HYES

LCM

HT3503L

Page 21 of 33

3. OPTICAL CHARACTERISTICS

3.1 Characteristics

Electrical and Optical Characteristics

No.	Item	symbol / temp.		Min.	Typ.	Max.	Unit	Note	
1	Response Time	Tr	25 °C	-	15	20	ms	2	
		Tf	25 °C	-	35	50			
2	Viewing Angle	Front-Rear	$\Theta 1$	$\Phi =$	-15	-	35	degree	3
		Left-Right	$\Theta 2$	270°	-45	-	45		
3	Contrast Ratio	Cr	25 °C	150	250	-	-	4	
4	Red x-code	Rx	25 °C	0.46	0.51	0.56	-	5	
	Red y-code	Ry		0.29	0.34	0.39			
	Green x-code	Gx		0.27	0.32	0.37			
	Green y-code	Gy		0.53	0.58	0.63			
	Blue x-code	Bx		0.09	0.14	0.19			
	Blue y-code	By		0.04	0.09	0.14			
	White x-code	Wx		0.24	0.29	0.34			
	White y-code	Wy		0.26	0.31	0.36			
	Brightness	Y	250	300	-	cd/m ²			
5	Brightness Uniformity		25 °C	80	-	-	%	6	

Date : Feb. 04, 2007

TECHNICAL SPECIFICATION

HYES

LCM

HT3503L

Page 22 of 33

3.2 Definition of optical characteristics

Measurement condition :

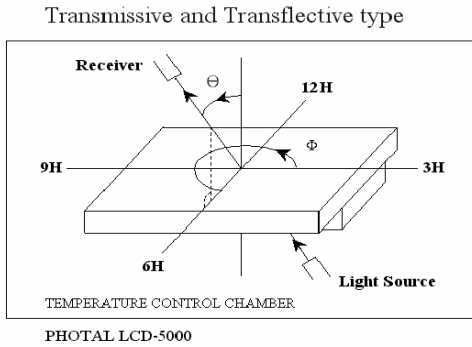

[Note 1] Definition of LCD Driving Vop and Waveform :

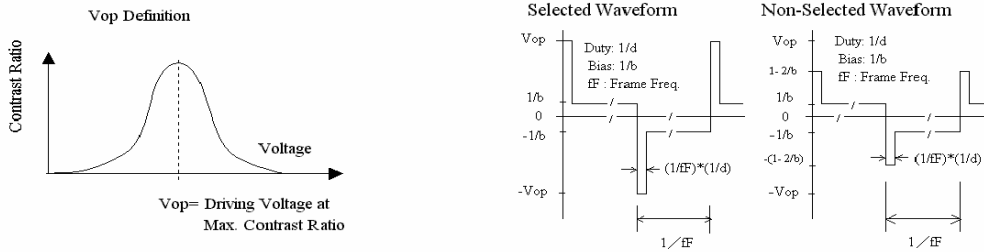

[Note 2] Definition of Response Time

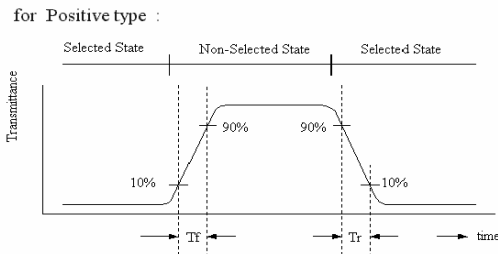

[Note 3] Definition of Viewing Angle :

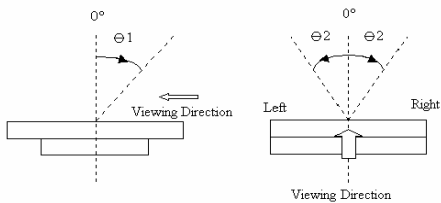

[Note 4] Definition of Contrast Ratio :

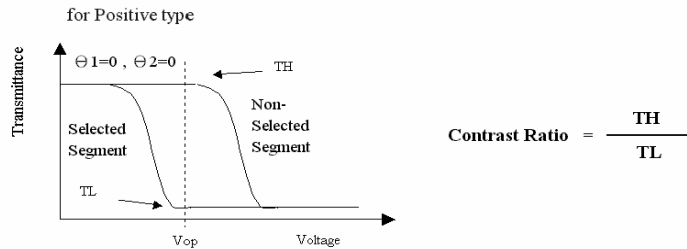

[Note 5] Definition of measurement of Color Chromaticity and Brightness

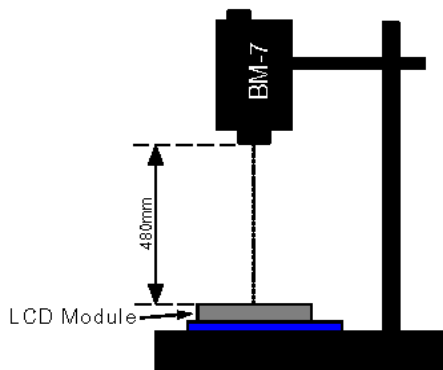

[Note 6] Definition of Brightness Uniformity

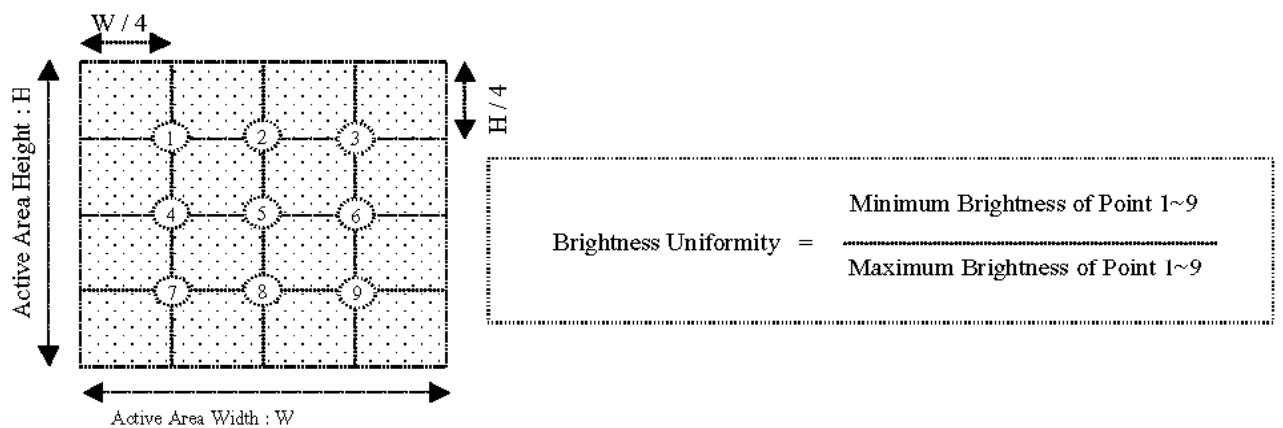

[Note 7] Definition of Measurement of Reflectance

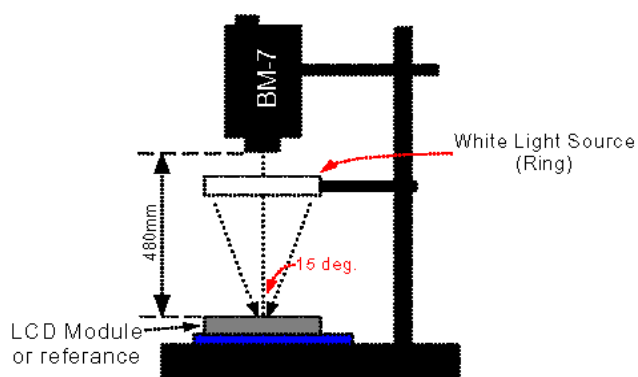

4. RELIABILITY :

Item No	Items	Condition	Remark
1	High temperature operating	70 °C , 200 hours	Finish product (With polarizer)
2	Low temperature operating	-20 °C , 200 hours	Finish product (With polarizer)
3	High temperature storage	80 °C , 200 hours	Finish product (With polarizer)
4	Low temperature storage	-30 °C , 200 hours	Finish product (With polarizer)
5	High temperature & humidity storage	60°C, 90%RH, 100 hours	Finish product (With polarizer)
6	Thermal Shock storage	-30°C, 30min.<=> 80°C, 30min. 10 Cycles	Finish product (With polarizer)
7	Vibration test	10 => 55 =>10 => 55 => 10 Hz , within 1 minute Amplitude : 1.5mm. 15 minutes for each Direction (X,Y,Z)	Finish product (With polarizer)
8	Drop test	Packed, 100CM free fall, 6 sides, 1 corner, 3edges	Finish product (With polarizer)
9	Life time	50,000 hours 25°C , 70%RH below , specification condition driving	Finish product (With polarizer)

- * One single product test for only one item.
- * Judgment after test : keep in room temperature for more than 2 hours.
 - Current consumption < 2 times of initial value
 - Contrast > 1/2 initial value
 - Function : work normally

Date : Feb. 04, 2007

TECHNICAL SPECIFICATION

HYES

LCM

HT3503L

Page 25 of 33

5. PRODUCT HANDING AND APPLICATION

PRECAUTION FOR HANDLING LCM

- The LCD module contains a C-MOS LSI. People who operate the LCM should wear ESD protection equipment to prevent ESD hurt on products.
- Do not input any signal before power is turned on.
- Do not take LCM from its packaging bag until it is assembled.
- Peel off the LCM protective film slowly since static electricity may be generated.
- Pay attention to the humidity of the work shop, 50~60%RH is satisfactory.
- Use a non-leak iron for soldering LCM.
- Do not touch the display surface or connection terminals area with bare hands. Smudges on the display surface reduce the insulation between terminals.
- Cautions for soldering to LCM:
Condition for soldering I/O terminals:
Temperature at iron tip :280°C±10°C.
Soldering time : 3~4sec./ terminals.
Type of solder : Eutectic solder(rosin flux filled).

PRECAUTION IN USE OF LCD

- Do not contact or scratch the front surface and the contact pads of a LCD panel with hard materials such as metal or glass or with one's nail.
- To clean the surface , wipe it gently with soft cloth dampened by alcohol.
- Do not attempt to wipe off the contact pads.
- Keep LCD panels away from direct sunlight , also avoid them in high-temperature & high humidity environment for a long period.
- Do not drive LCD panels by DC voltage.
- Do not expose LCD panels to organic solvent.
- Liquid in LCD is hazardous substance. In case a contact with liquid crystal material is occurred, be sure to immediately wash such material away by soap and water.
- The polarizer is easily damaged and should be handle with special care. Don't press or rub it with hard objects.

PRECAUTION FOR STORING LCM

- To avoid degradation of the device , do not store the module under the conditions of direct sunlight , high temperature or high humidity . Keep the module in bags designed to prevent static electricity charging under low temperature / normal humidity conditions(avoid high temperature / high humidity and low temperature below 0°C)

USING ON MEDICAL CARE , SAFETY OR HAZARDOUS APPLICATION OR SYSTEM

- For the application in medical care, safety and hazardous products or systems, an authorization from HYES is required. HYES will not responsible for any damage or loss which caused by the products without any authorization given by HYES.
- This product is not allowed to be designed and used for military application and/or purpose.
- The delivery of this product to the countries and/or regions where the embargoes are imposed by U.N. is prohibited.

Date : Feb. 04, 2007

TECHNICAL SPECIFICATION

HYES

LCM

HT3503L

Page 26 of 33

6. DATE CODE OF PRODUCTS

- Date code will be shown on each product :

- **Y MM DD - XXX**

Year Month Day - Production lots

- Example: 2 1 2 2 3 - 0 0 3 ==> Year 2002, Dec.,23rd , Batch no.03

NOTE:

- T.B.D pcs / Tray
- T.B.D Tray / Box
- T.B.D Box / Carton
- T.B.D pcs / Carton

- (1) Be warned ,the direction of the tray has to turn it by 180 degree before stack it up. Otherwise, it will be packager's responsibility!!
- (2) Safe Stack : 5 cartons only

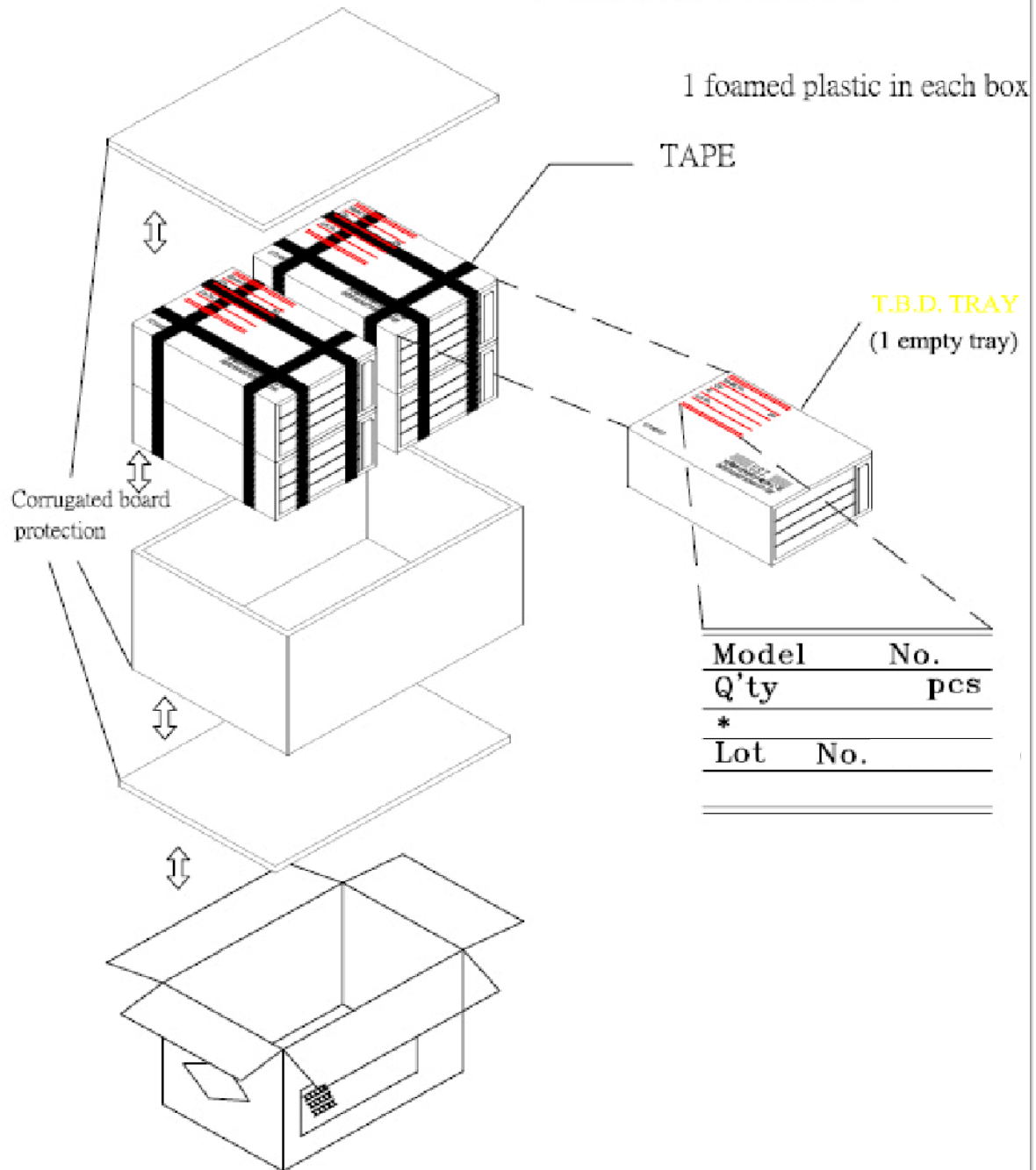

Date : Feb. 04, 2007

TECHNICAL SPECIFICATION

HYES

LCM

HT3503L

Page 29 of 33

8. INSPECTION STANDARD

8.1. QUALITY :

THE QUALITY OF GOODS SUPPLIED TO PURCHASER SHALL COME UP TO THE FOLLOWING STANDARD.

8.1.1. THE METHOD OF PRESERVING GOODS

AFTER DELIVERY OF GOODS FROM **HYES** TO PURCHASER. PURCHASER SHALL CONTROL THE LCM AT -10 °C ~ 40 °C ,AND IT MIGHT BE DESIRABLE TO KEEP AT THE NORMAL ROOM TEMPERATURE AND HUMIDITY UNTIL INCOMING INSPECTION OR THROWING INTO PROCESS LINE.

8.1.2. INCOMING INSPECTION

(A) THE METHOD OF INSPECTION

IF PURCHASER MAKE AN INCOMING INSPECTION , A SAMPLING PLAN SHALL BE APPLIED ON THE CONDITION THAT QUALITY OF ONE DELIVERY SHALL BE REGARDED AS ONE LOT.

(B) THE STANDARD OF QUALITY

ISO-2859-1 (or MIL-STD-105D), LEVEL II SINGLE PLAN.

CLASS	AQL(%)
CRITICAL	0.4 %
MAJOR	0.65 %
MINOR	1.5 %
TOTAL	1.5 %

EVERY ITEM SHALL BE INSPECTED ACCORDING TO THE CLASS.

(C) MEASURE

IF AS THE RESULT OF ABOVE RECEIVING INSPECTION , A LOT OUT IS DISCOVERED.

PURCHASER SHALL BE INFORM SELLER OF IT WITHIN SEVEN DAYS. BUT FIRST SHIPMENT WITHIN FOURTEEN DAYS.

8.1.3. WARRANTY POLICY

HYES WILL PROVIDE ONE-YEAR WARRANTY FOR THE PRODUCTS ONLY IF UNDER SPECIFICATION OPERATING CONDITIONS. **HYES** WILL REPLACE NEW PRODUCTS FOR THESE DEFECT PRODUCTS WHICH UNDER WARRANTY PERIOD AND BELONG TO THE RESPONSIBILITY OF **HYES** .

8.2. CHECKING CONDITION

8.2.1. CHECKING DIRECTION SHALL BE IN THE 45 DEGREE AREA TO FACE THE SAMPLE.

8.2.2. CHECKER SHALL SEE OVER 30 cm. WITH BARE EYES FAR FROM SAMPLE AND USING 2 PCS. OF 20W FLUORESCENT LAMP.

Date : Feb. 04, 2007

TECHNICAL SPECIFICATION

HYES

LCM

HT3503L

Page 30 of 33

8.3. INSPECTION PLAN :

CLASS	ITEM	JUDGEMENT	CLASS
PACKING & INDICATE	1. OUTSIDE AND INSIDE PACKAGE	"MODEL NO." , "LOT NO." AND "QUANTITY" SHOULD INDICATE ON THE PACKAGE.	Minor
	2. MODEL MIXED AND QUANTITY	OTHER MODEL MIXED.....REJECTED QUANTITY SHORT OR OVER.....REJECTED	Critical
	3. PRODUCT INDICATION	"MODEL NO." SHOULD INDICATE ON THE PRODUCT	Major
ASSEMBLY	4. DIMENSION, LCD GLASS SCRATCH AND SCRIBE DEFECT.	ACCORDING TO SPECIFICATION OR DRAWING.	Major
APPEARANCE	5. VIEWING AREA	POLARIZER EDGE OR LCD'S SEALING LINE IS VISABLE IN THE VIEWING AREAREJECTED	Minor
	6. BLEMISH - BLACK SPOT - WHITE SPOT IN THE LCD AND LCD GLASS CRACKS	ACCORDING TO STANDARD OF VISUAL INSPECTION (INSIDE VIEWING AREA)	Minor
	7. BLEMISH - BLACK SPOT WHITE SPOT AND SCRATCH ON THE POLARIZER	ACCORDING TO STANDARD OF VISUAL INSPECTION (INSIDE VIEWING AREA)	Minor
	8. BUBBLE IN POLARIZER	ACCORDING TO STANDARD OF VISUAL INSPECTION (INSIDE VIEWING AREA)	Minor
	9. LCD'S RAINBOW COLOR	STRONG DEVIATION COLOR (OR NEWTON RING) OF LCD.....REJECTED. OR ACCORDING TO LIMITED SAMPLE (IF NEEDED, AND INSIDE VIEWING AREA)	Minor
ELECTRICAL	10. ELECTRICAL AND OPTICAL CHARACTERISTICS (CONTRAST - VOP - CHROMATICITY ... ETC)	ACCORDING TO SPECIFICATION OR DRAWING . (INSIDE VIEWING AREA)	Critical
	11. MISSING PATTERN	MISSING DOT - LINE - CHARACTERREJECTED	Critical
	12. SHORT CIRCUIT - WRONG PATTERN DISPLAY	NON DISPLAY - WRONG PATTERN DISPLAY - CURRENT CONSUMPTION OUT OF SPECIFICATION..... REJECTED	Critical
	13. PIN HOLE - PATTERN DEFORMITY	ACCORDING TO STANDARD OF VISUAL INSPECTION	Minor

Date : Feb. 04, 2007

TECHNICAL SPECIFICATION

HYES

LCM

HT3503L

Page 31 of 33

8.4. STANDARD OF VISUAL INSPECTION

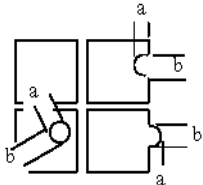
NO.	CLASS	ITEM	JUDGEMENT																									
8.4.1	MINOR	· BLEMISH · BLACK SPOT · WHITE SPOT IN THE LCD. · BLEMISH · BLACK SPOT · WHITE SPOT AND SCRATCH ON THE POLARIZER	(A) ROUND TYPE: unit : mm. <table border="1"> <thead> <tr> <th>DIAMETER (mm.)</th> <th>ACCEPTABLE Q'TY</th> </tr> </thead> <tbody> <tr> <td>$\Phi \leq 0.1$</td> <td>DISREGARD</td> </tr> <tr> <td>$0.1 < \Phi \leq 0.2$</td> <td>2</td> </tr> <tr> <td>$0.2 < \Phi \leq 0.25$</td> <td>1</td> </tr> <tr> <td>$0.25 < \Phi$</td> <td>0</td> </tr> </tbody> </table> NOTE: $\Phi = (\text{LENGTH} + \text{WIDTH}) / 2$ (B) LINER TYPE: unit : mm. <table border="1"> <thead> <tr> <th>LENGTH</th> <th>WIDTH</th> <th>ACCEPTABLE Q'TY</th> </tr> </thead> <tbody> <tr> <td>-----</td> <td>$W \leq 0.03$</td> <td>DISREGARD</td> </tr> <tr> <td>$L \leq 5.0$</td> <td>$0.03 < W \leq 0.05$</td> <td>3</td> </tr> <tr> <td>$L \leq 5.0$</td> <td>$0.05 < W \leq 0.07$</td> <td>1</td> </tr> <tr> <td>-----</td> <td>$0.07 < W$</td> <td>FOLLOW ROUND TYPE</td> </tr> </tbody> </table>	DIAMETER (mm.)	ACCEPTABLE Q'TY	$\Phi \leq 0.1$	DISREGARD	$0.1 < \Phi \leq 0.2$	2	$0.2 < \Phi \leq 0.25$	1	$0.25 < \Phi$	0	LENGTH	WIDTH	ACCEPTABLE Q'TY	-----	$W \leq 0.03$	DISREGARD	$L \leq 5.0$	$0.03 < W \leq 0.05$	3	$L \leq 5.0$	$0.05 < W \leq 0.07$	1	-----	$0.07 < W$	FOLLOW ROUND TYPE
DIAMETER (mm.)	ACCEPTABLE Q'TY																											
$\Phi \leq 0.1$	DISREGARD																											
$0.1 < \Phi \leq 0.2$	2																											
$0.2 < \Phi \leq 0.25$	1																											
$0.25 < \Phi$	0																											
LENGTH	WIDTH	ACCEPTABLE Q'TY																										
-----	$W \leq 0.03$	DISREGARD																										
$L \leq 5.0$	$0.03 < W \leq 0.05$	3																										
$L \leq 5.0$	$0.05 < W \leq 0.07$	1																										
-----	$0.07 < W$	FOLLOW ROUND TYPE																										
8.4.2	MINOR	BUBBLE IN POLARIZER	unit : mm. <table border="1"> <thead> <tr> <th>DIAMETER</th> <th>ACCEPTABLE Q'TY</th> </tr> </thead> <tbody> <tr> <td>$\Phi \leq 0.15$</td> <td>DISREGARD</td> </tr> <tr> <td>$0.15 < \Phi \leq 0.5$</td> <td>2</td> </tr> <tr> <td>$0.5 < \Phi$</td> <td>0</td> </tr> </tbody> </table>	DIAMETER	ACCEPTABLE Q'TY	$\Phi \leq 0.15$	DISREGARD	$0.15 < \Phi \leq 0.5$	2	$0.5 < \Phi$	0																	
DIAMETER	ACCEPTABLE Q'TY																											
$\Phi \leq 0.15$	DISREGARD																											
$0.15 < \Phi \leq 0.5$	2																											
$0.5 < \Phi$	0																											
8.4.3	MINOR	PIN HOLE · PATTERN DEFORMITY	unit : mm.  <table border="1"> <thead> <tr> <th>DIAMETER</th> <th>ACC. Q'TY</th> </tr> </thead> <tbody> <tr> <td>$\Phi \leq 0.1$</td> <td>DISREGARD</td> </tr> <tr> <td>$0.1 < \Phi \leq 0.25$</td> <td>3</td> </tr> <tr> <td>$0.25 < \Phi$</td> <td>0</td> </tr> </tbody> </table> <p>$\Phi = (a+b)/2$</p>	DIAMETER	ACC. Q'TY	$\Phi \leq 0.1$	DISREGARD	$0.1 < \Phi \leq 0.25$	3	$0.25 < \Phi$	0																	
DIAMETER	ACC. Q'TY																											
$\Phi \leq 0.1$	DISREGARD																											
$0.1 < \Phi \leq 0.25$	3																											
$0.25 < \Phi$	0																											

Date : Feb. 04, 2007

TECHNICAL SPECIFICATION

HYES

LCM

HT3503L

Page 32 of 33

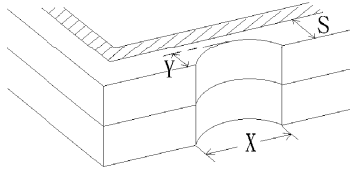
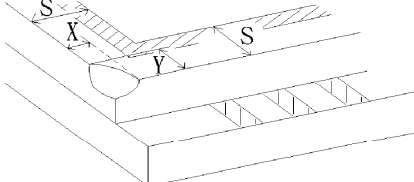
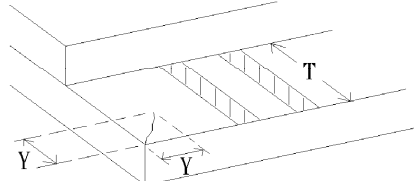
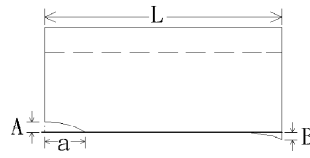
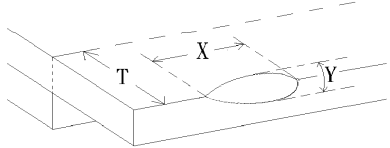
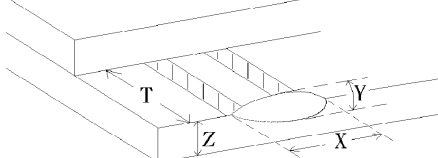
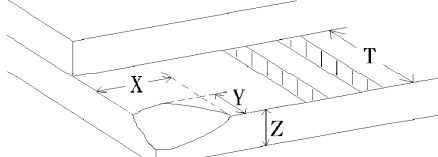
NO.	CLASS	ITEM	JUDGEMENT
8.4.4	MINOR	CHIPPING	 $Y > S$ REJ.
8.4.5	MINOR	CHIPPING	 $X \text{ or } Y > S$ REJ.
8.4.6	MAJOR	GLASS CRACK	 $Y > (1/2) T$ REJ.
8.4.7	MAJOR	SCRIBE DEFECT	 <ol style="list-style-type: none"> $a > L/3$, $A > 1.5\text{mm}$. REJ. B : ACCORDING TO DIMENSION
8.4.8	MINOR	CHIPPING (ON THE TERMINAL AREA)	 $\Phi = (x+y)/2 > 2.5 \text{ mm}$ REJ.
8.4.9	MINOR	CHIPPING (ON THE TERMINAL SURFACE)	 $Y > (1/3) T$ REJ.
8.4.10	MINOR	CHIPPING	 $Y > T$ REJ.

Date : Feb. 04, 2007

TECHNICAL SPECIFICATION



LCM

HT3503L

Page 33 of 33