

APPROVAL

PART NO.	DESCRIPTION	REMARKS
HT3503LH-T-01	LCD MODULE (320 × RGB × 240) Hgh Brightness, Touch Screen	* ROHS compliant

CUSTOMER APPLICATION P/N	
APPROVED BY	
DATE	

PLEASE KINDLY FIND AND APPROVE THE SPECIFICATIONS INSERTED
HEREIN AND RETURN ONE COPY HERE OF WITH YOUR SIGNATURE OF APPROVAL.

PERPARED BY	CHECKED BY	CONFIRMED BY



HYES Optoelectronics, Inc.

2000 Wyatt Drive Suite 6
Santa Clara, CA 95054 USA

CONTENTS:

No.	Item
1	BASIC SPECIFICATION 1.1 Mechanical Specification 1.2 Display Specification 1.3 Outline Dimension 1.4 Block Diagram 1.5 Interface Pin
2	ELECTRICAL CHARACTERISTICS 2.1 Absolute Maximum Ratings 2.2 DC Characteristics 2.2.1 Back-light 2.3 AC Characteristics
3	OPTICAL CHARACTERISTICS 3.1 Condition 3.2 Definition of Optical Characteristics
4	RELIABILITY
5	PRODUCT HANDLING AND APPLICATION
6	DATECODE
7	PACKING & LOTNO
8	INSPECTION STANDARD

REVISION HISTORY

Date	Rev. No.	Page	Summary
6-Nov-2009	-	ALL	- 1'st Issue

Date : Nov. 06, 2009

TECHNICAL SPECIFICATION

The logo for HYES, consisting of the word "HYES" in white capital letters on a dark orange rectangular background.

LCM

HT3503LH-T-01

Page 2 of 33

1. BASIC SPECIFICATION

1.1 Mechanical specifications

Items	Nominal Dimension	Unit
Active screen size	3.5" diagonal	-
Dot Matrix	320*RGB*240	dots
Module Size (W x H x T)	76.9 x 63.9 x 4.3	mm.
Active Area (W x H)	70.08 x 52.56	mm.
Dot Pitch (W x H)	0.219 x 0.219	mm.
Color depth	262K	color
Interface	8-bits serial/24-bits parallel RGB / CCIR601/656	-
Driving IC Package	COG	-

* The maximum color depth of this driver IC is 262K colors ,not 16.7M.

1.2 Display specification

Display	Descriptions	Note
LCD Type	a-Si TFT	-
LCD Mode	TN/Normally White	-
Polarizer Mode	Transmissive	-
Polarizer Surface	Normal	-
Pixel arrangement	RGB-stripe	-
Backlight Type	LED	-
Viewing Direction	6 O'clock Direction	-

Color tone is slightly changed by temperature and driving voltage.

1.3 Outline Dimension

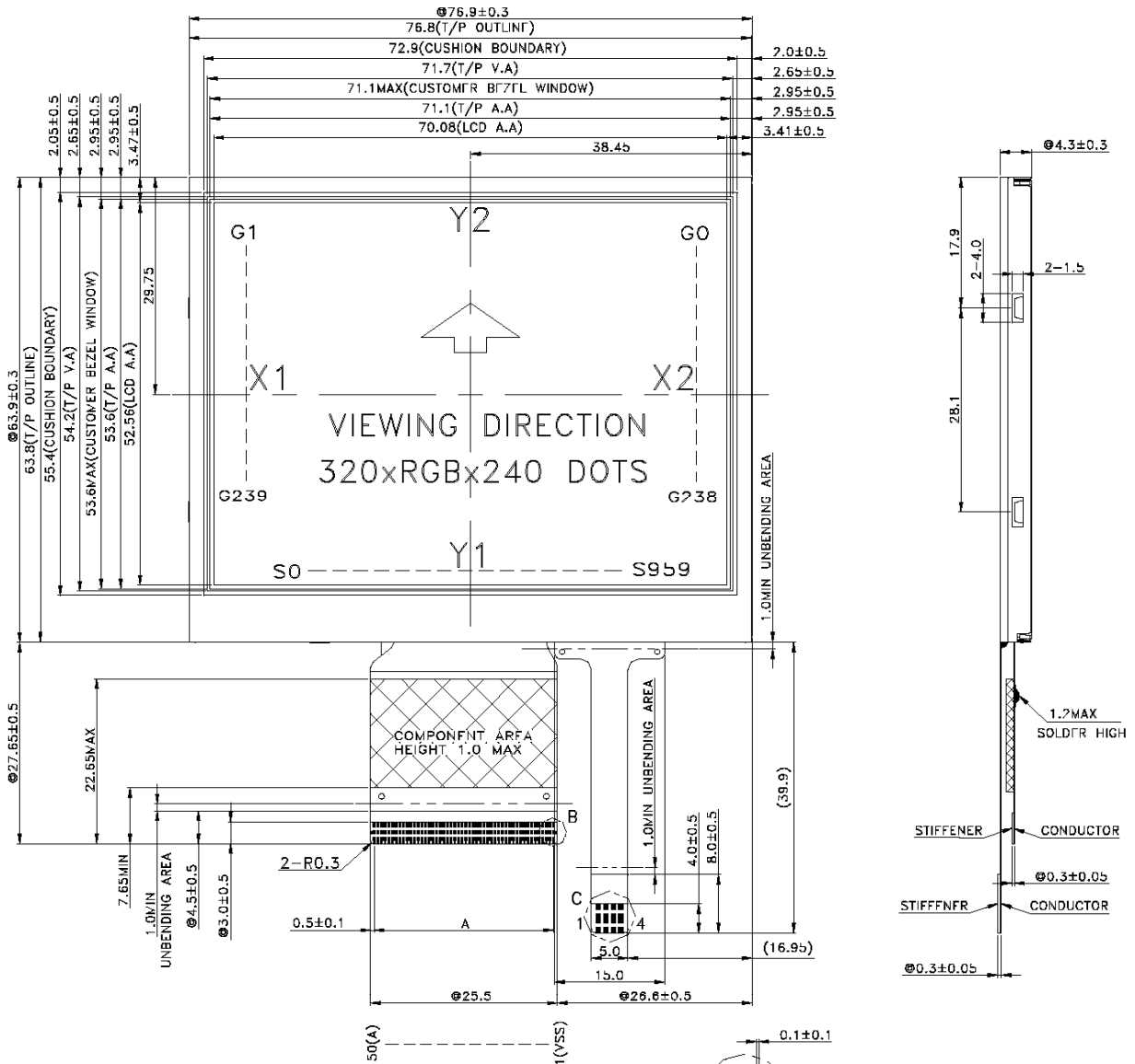

NOTE :

- LCD:TFT TRANSMISSIVE MODE,NORMAL WHITE
- VIEWING DIRECTION : 6 O'CLOCK
- Top : $-20 \sim 70^{\circ}\text{C}$, Ist : $-30 \sim 80^{\circ}\text{C}$
- DRIVER IC : HX8238-A02
- "@"KFY DIMFNSION.
- TOLERANCE FOR NOT ASSIGNED: ± 0.2
- LCD COLOR : WHITE , 10 PCS DICF
CONSTANT CURRENT IF=40.0mA ; VLED=17.0V(Typ)
- A: 24.5 ± 0.05 (p0.5x49) , W= 0.3 ± 0.05
- THE MINIMUM BENDING RADIUS (INNER) OF THE FPC IS 0.5mm.
- CUSTOMER BEZEL WINDOW MUST BE 71.1mm X 53.6mm OR SMALLER THAN THIS
- CUSTOMER CUSHION WINDOW MUST BE 72.7mm X 55.2mm OR LARGER THAN THIS

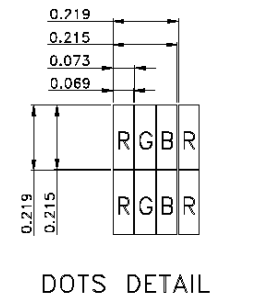
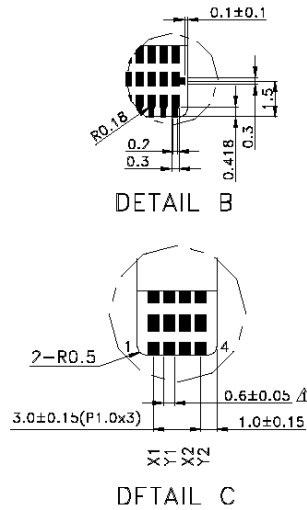

Date : Nov. 06, 2009

TECHNICAL SPECIFICATION



LCM

HT3503LH-T-01

Page 4 of 33

1.4 Block diagram:

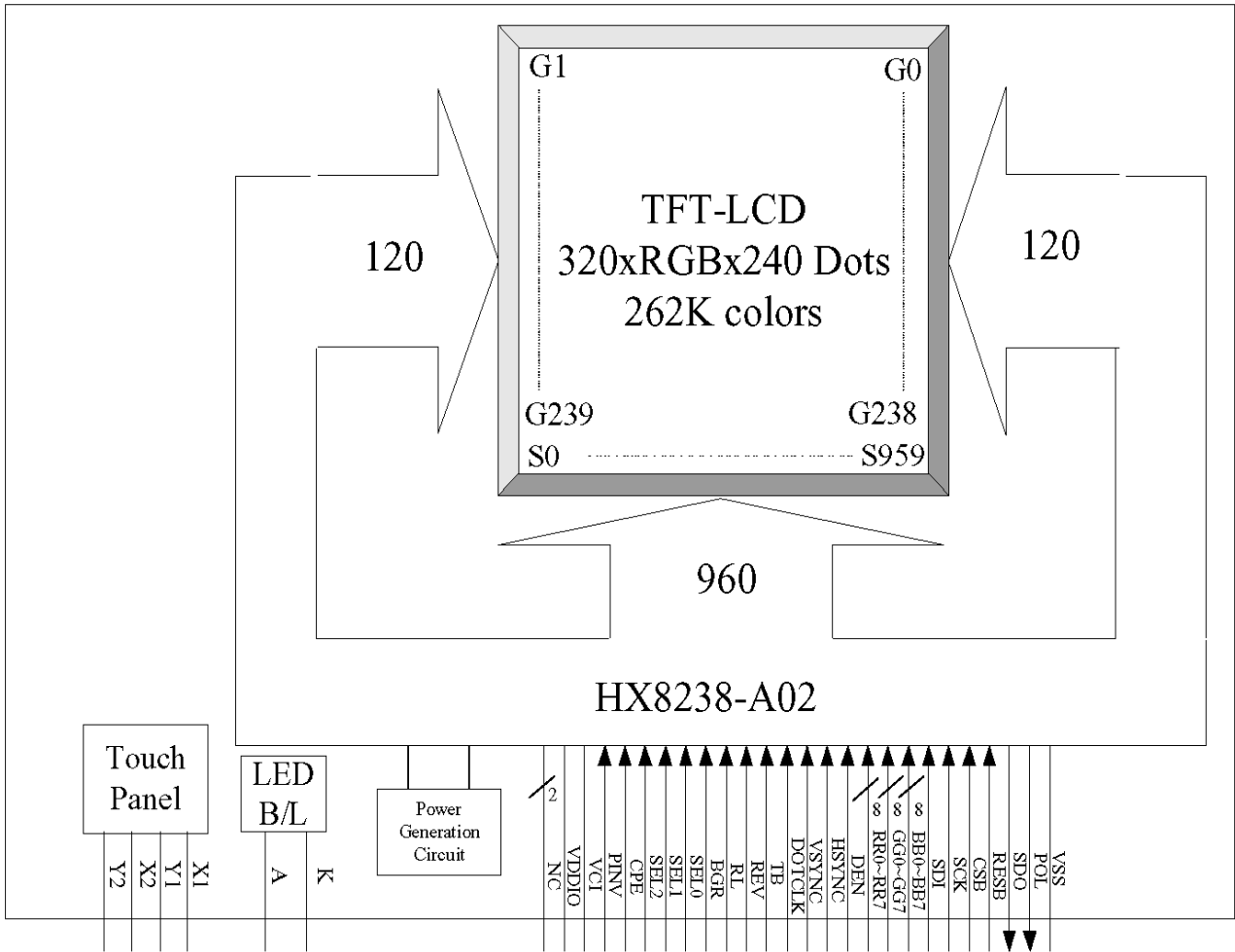

Date : Nov. 06, 2009

TECHNICAL SPECIFICATION

HYES

LCM

HT3503LH-T-01

Page 5 of 33

1.5 Interface pin :

Pin No.	Pin Name	I/O	Description
1	VSS	P	System ground pin of the IC. - Connect to system ground
2	POL	O	Polarity signal to monitor VCOM signal. - Leave it OPEN when not used
3	SDO	O	Data output pin in serial mode. - Leave it OPEN when not used
4	RESB	I	System reset pin. Internal pull high.
5	CSB	I	Chip select pin of serial interface. Internal pull high. - Leave it OPEN when not used.
6	SCK	I	Clock pin of serial interface. Internal pull high. - Leave it OPEN when not used
7	SDI	I	Data input pin in serial mode. Internal pull high. - Leave it OPEN when not used
8~31	BB [0: 7] GG [0: 7] RR [0: 7]	I	Graphic Data Input Pins. Internal pull low. - RR [0:7]: Red Data - 8-bits - GG [0:7]: Green Data - 8-bits - BB [0:7]: Blue Data - 8-bits For 8 bit interface, only RR[0:7] are used. For unused pins, please connect to VSS or floating.
32	DEN	I	Display enable pin from controller. Connect to VDDIO or floating if not used.
33	HSYNC	I	Line synchronization signal. Internal pull high. - Fixed to VDDIO or floating if not used
34	VSYNC	I	Frame synchronization signal. Internal pull high. - Fixed to VDDIO or floating if not used.
35	DOTCLK	I	Dot-clock signal and oscillator source.

Date : Nov. 06, 2009

TECHNICAL SPECIFICATION

HYES

LCM

HT3503LH-T-01

Page 6 of 33

Pin No.	Pin Name	I/O	Description																																													
36	TB	I	Input pin to select the Gate driver scan direction. - Connect to VSS for Gate scan from G239 to G0 (reverse scan) - Connect to VDDIO for Gate scan from G0 to G239 (normal scan)																																													
37	REV	I	Input pin to select the display reversion. - Connect to VDDIO mapping data '0' to maximum pixel voltage for normally white panel - Connect to VSS for mapping data '0' to minimum pixel voltage for normally black panel																																													
38	RL	I	Input pin to select the Source driver data shift direction. - Connect to VDDIO for display first RGB data at S0-S2. - Connect to VSS for display first RGB data at S959-S957.																																													
39	BGR	I	Input pin to select the color mapping. - Connect to VDDIO for Blue-Green-Red mapping. - Connect to VSS for Red-Green-Blue mapping.																																													
40-42	SELO~2	I	Input pin to select input interface mode.																																													
			<table border="1"> <thead> <tr> <th>SEL2</th> <th>SEL1</th> <th>SELO</th> <th>Format</th> <th>Operating Frequency</th> </tr> </thead> <tbody> <tr> <td>0</td> <td>0</td> <td>0</td> <td>Parallel-RGB data format (only support stripe type color filter)</td> <td>6.5MHz</td> </tr> <tr> <td>0</td> <td>0</td> <td>1</td> <td>Serial-RGB data format</td> <td>19.5MHz</td> </tr> <tr> <td>0</td> <td>1</td> <td>0</td> <td>CCIR 656 data format (640RGB)</td> <td>24.54MHz</td> </tr> <tr> <td>0</td> <td>1</td> <td>1</td> <td>CCIR 656 data format (720RGB)</td> <td>27MHz</td> </tr> <tr> <td>1</td> <td>0</td> <td>0</td> <td>YUV mode A data format (Cr-Y-Cb-Y)</td> <td>24.54MHz</td> </tr> <tr> <td>1</td> <td>0</td> <td>1</td> <td>YUV mode A data format (Cr-Y-Cb-Y)</td> <td>27MHz</td> </tr> <tr> <td>1</td> <td>1</td> <td>0</td> <td>YUV mode B data format (Cb-Y-Cr-Y)</td> <td>27MHz</td> </tr> <tr> <td>1</td> <td>1</td> <td>1</td> <td>YUV mode B data format (Cb-Y-Cr-Y)</td> <td>24.54MHz</td> </tr> </tbody> </table>	SEL2	SEL1	SELO	Format	Operating Frequency	0	0	0	Parallel-RGB data format (only support stripe type color filter)	6.5MHz	0	0	1	Serial-RGB data format	19.5MHz	0	1	0	CCIR 656 data format (640RGB)	24.54MHz	0	1	1	CCIR 656 data format (720RGB)	27MHz	1	0	0	YUV mode A data format (Cr-Y-Cb-Y)	24.54MHz	1	0	1	YUV mode A data format (Cr-Y-Cb-Y)	27MHz	1	1	0	YUV mode B data format (Cb-Y-Cr-Y)	27MHz	1	1	1	YUV mode B data format (Cb-Y-Cr-Y)	24.54MHz
			SEL2	SEL1	SELO	Format	Operating Frequency																																									
			0	0	0	Parallel-RGB data format (only support stripe type color filter)	6.5MHz																																									
			0	0	1	Serial-RGB data format	19.5MHz																																									
			0	1	0	CCIR 656 data format (640RGB)	24.54MHz																																									
			0	1	1	CCIR 656 data format (720RGB)	27MHz																																									
			1	0	0	YUV mode A data format (Cr-Y-Cb-Y)	24.54MHz																																									
			1	0	1	YUV mode A data format (Cr-Y-Cb-Y)	27MHz																																									
1	1	0	YUV mode B data format (Cb-Y-Cr-Y)	27MHz																																												
1	1	1	YUV mode B data format (Cb-Y-Cr-Y)	24.54MHz																																												

Date : Nov. 06, 2009

TECHNICAL SPECIFICATION

HYES

LCM

HT3503LH-T-01

Page 7 of 33

Pin No.	Pin Name	I/O	Description
43	CPE	I	Input pin to enable internal charge pump circuit. Internal pull high. - Connect to VDDIO to enable internal charge pump. - Connect to VSS to disable internal charge pump
44	PINV	I	Control the polarity of POL signal. Internal pull low. - Connect to VDDIO, POL phase is reversed with internal VCOM signal. - Connect to VSS, POL phase is same with internal VCOM signal.
45	VCI	P	Power Supply for Analog Circuits.
46	VDDIO	P	Voltage input pin for I/O logic.
47	NC	-	No connection.
48	NC	-	No connection.
49	K	P	Backlight LED' s cathode.
50	A	P	Backlight LED' s anode.

Touch screen panel pin:

1	X1	-	Touch screen.
2	Y1	-	Touch screen.
3	X2	-	Touch screen.
4	Y2	-	Touch screen.

2. ELECTRICAL CHARACTERISTICS

2.1 Absolute Maximum Ratings

Items	Symbol	Min.	Max.	Unit
Input voltage	VCI	VSS-0.3	5.0	V
Supply Voltage	VDDIO	VSS-0.3	4.0	V
Operate temperature range	TOP	-20	70	°C
Storage temperature range	TST	-30	80	°C

Date : Nov. 06, 2009

TECHNICAL SPECIFICATION

HYES

LCM

HT3503LH-T-01

Page 8 of 33

2.2 DC Characteristics

Items	Symbol	Min.	Typ.	Max.	Unit	Condition
Power supply voltage	VCI	2.5	3.3	3.6	V	
Power supply pin of IO pins	VDDIO	1.4	3.3	3.6	V	
Current consumption	I(VCI+VDDIO)	-	-	16	mA	NOTE
Dot Clock	DCK	-	7.5	10	MHz	
Serial Clock	XSCK	-	19.5	30	MHz	

NOTE : The method to illuminate the LCD panel is using the 2-4-7 command under the measuring condition.

Measuring Condition :

Standard Value MAX.

Ta = 25°C

VCI = 3.3V

VDDIO = 3.3V

Dot Clock = 7.5MHz

Display Patten = Checkered pattern



0 gray black pattern

2-2.1 Back-light Characteristics

Parameter	Symbol	Min	Typ	Max	Unit	Test Condition	Note
Supply Current	If	-	-	40	mA	Ta=25°C	-
Supply Voltage	VF	-	17	-	V	Ta=25°C	-
Brightness	Br	7500	-	-	cd/m ²	Ta=25°C	-
Half-Life Time	Lf	-	50000	-	hrs	-	1

Note1: The " Half-Life Time" is defined as the LED chip brightness decreases to 50% than original brightness, Based on Ta 25±2°C, 60±10% RH condition .

Date : Nov. 06, 2009

TECHNICAL SPECIFICATION

HYES

LCM

HT3503LH-T-01

Page 9 of 33

2.3 Command

LCD_Initial_HX-8238:

COMMAND	CODE	DESCRIPTION
R02H	0200	LCD-Driving-Waveform Control
R03H	6364	Power control 1
R04H	0440	Input Data and Color Filter Control
R0DH	3221	Power Control 2
R0EH	3100	Power Control 3

Adjust the Gamma Curve:

COMMAND	CODE	DESCRIPTION
R30H	0000	Gamma Control 1
R31H	0407	Gamma Control 1
R32H	0202	Gamma Control 1
R33H	0000	Gamma Control 1
R34H	0505	Gamma Control 1
R36H	0707	Gamma Control 1
R37H	0000	Gamma Control 1
R3AH	0904	Gamma Control 2
R3BH	0904	Gamma Control 2

Date : Nov. 06, 2009

TECHNICAL SPECIFICATION

HYES

LCM

HT3503LH-T-01

Page 10 of 33

2-4 AC Characteristics

2-4-1 8-bits serial/24-bits parallel RGB

AC Characteristics

(Unless otherwise specified, Voltage Referenced to V_{SS},

T_A = 25°C)

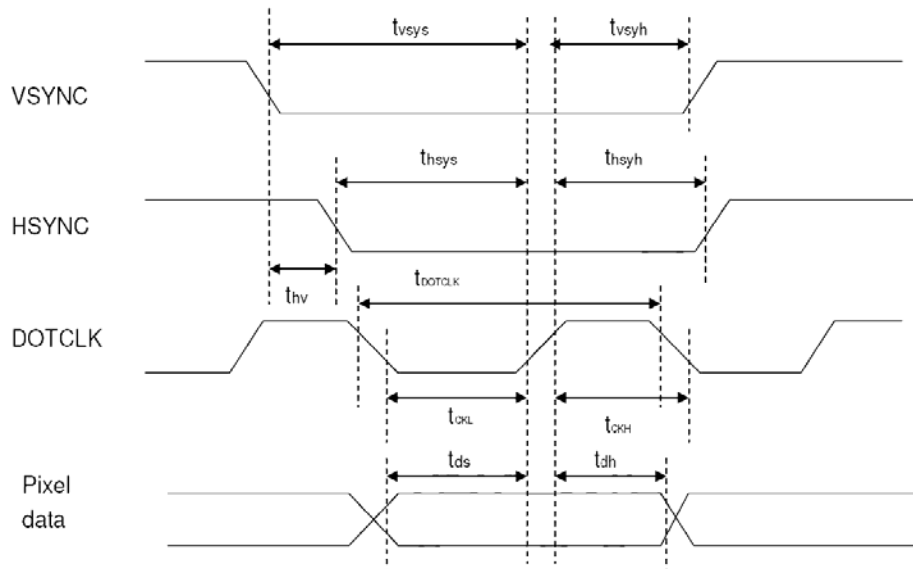

Figure 14. 1 Pixel Timing

Characteristics	Symbol	Min.		Typ.		Max.		Unit
		24bit	8bit	24bit	8bit	24bit	8bit	
DOTCLK Frequency	f _{DOTCLK}	-		7.5	19.5	10	30	MHz
DOTCLK Period	t _{DOTCLK}	100	33.3	154	51.3	-	-	ns
Vertical Sync Setup Time	t _{sys}	20	10	-	-	-	-	ns
Vertical Sync Hold Time	t _{syh}	20	10	-	-	-	-	ns
Horizontal Sync Setup Time	t _{hsys}	20	10	-	-	-	-	ns
Horizontal Sync Hold Time	t _{hsyh}	20	10	-	-	-	-	ns
Phase difference of Sync Signal Falling Edge	t _{hv}	1		-		240		t _{DOTCLK}
DOTCLK Low Period	t _{CKL}	50	15	-	-	-	-	ns
DOTCLK High Period	t _{CKH}	50	15	-	-	-	-	ns
Data Setup Time	t _{ds}	12	8	-	-	-	-	ns
Data hold Time	t _{dh}	12	8	-	-	-	-	ns
Reset pulse width	t _{RES}	10		-		-		us

Note: External clock source must be provided to DOTCLK pin of HX8238-A. The driver will not operate if absent of the clocking signal.

Table 14. 1 Pixel Timing

Date : Nov. 06, 2009

TECHNICAL SPECIFICATION

HYES

LCM

HT3503LH-T-01

Page 11 of 33

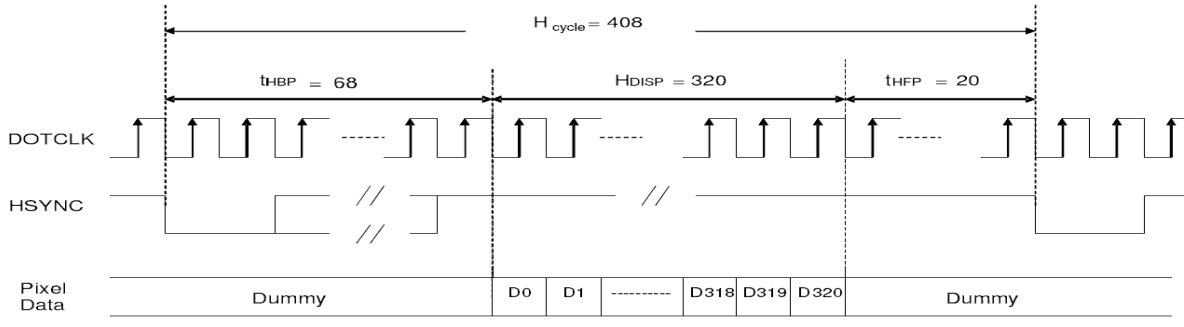

a) Horizontal Data Transaction Timing

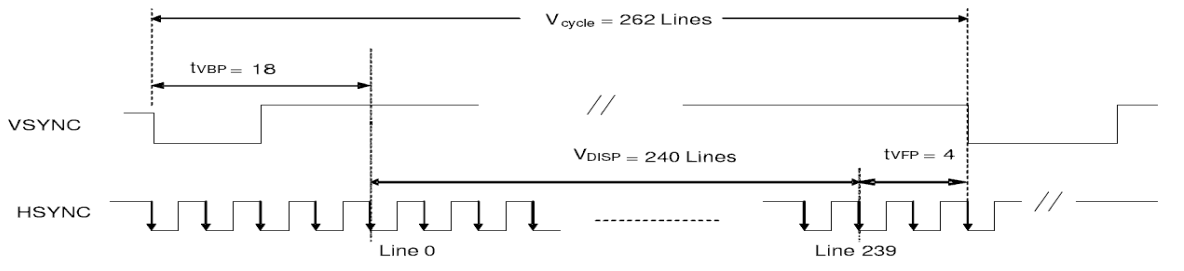

b) Vertical Data Transaction Timing

Figure 14. 2 Data transaction timing in parallel RGB (24 bit) interface (SYNC mode)

Characteristics	Symbol	Min		Typ		Max		Unit
		24bit	8 bit	24bit	8 bit	24bit	8 bit	
DOTCLK Frequency	fDOTCLK	-	-	7.5	19.5	10	30	MHz
DOTCLK Period	tDOTCLK	100	33.3	154	51.3	-	-	ns
Horizontal Frequency (Line)	fH	-		18.37		22.35		KHz
Vertical Frequency (Refresh)	fV	-		70		90		Hz
Horizontal Back Porch	thBP	-	-	68	204	-	-	tDOTCLK
Horizontal Front Porch	thFP	-	-	20	60	-	-	tDOTCLK
Horizontal Data Start Point	thBP	-	-	68	204	-	-	tDOTCLK
Horizontal Blanking Period	thBP + thFP	-	-	88	264	-	-	tDOTCLK
Horizontal Display Area	HDISP	-	-	320	960	-	-	tDOTCLK
Horizontal Cycle	Hcycle	-	-	408	1224	450	1350	tDOTCLK
Vertical Back Porch	tvBP	-		18		-		Lines
Vertical Front Porch	tvFP	-		4		-		Lines
Vertical Data Start Point	tvBP	-		18		-		Lines
Vertical Blanking Period	tvBP + tvFP	-		22		-		Lines
Vertical Display Area	NTSC	-		240		-		Lines
	PAL			280(PALM=0)				
				288(PALM=1)				
Vertical Cycle	NTSC	-		262		350		Lines
	PAL			313				

Table 14. 2 Data Transaction Timing in Normal Operating Mode

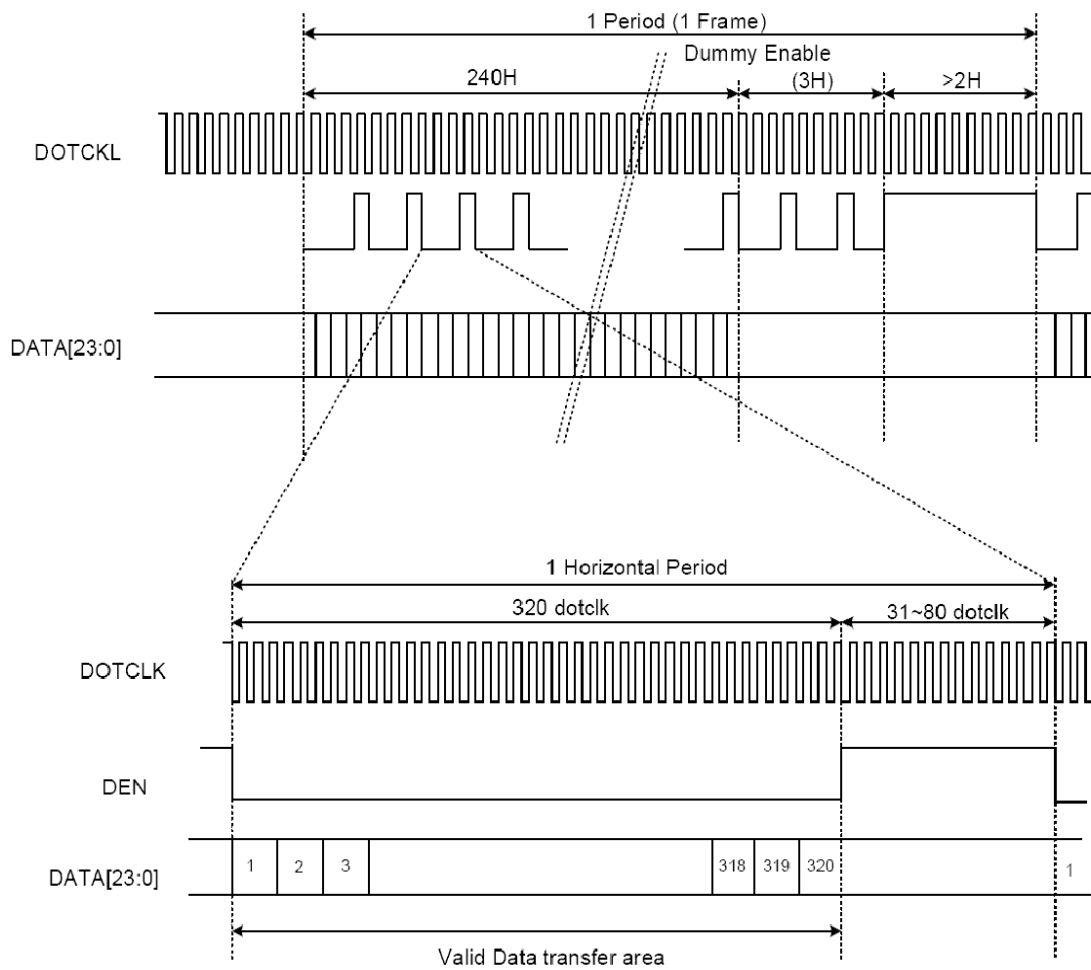
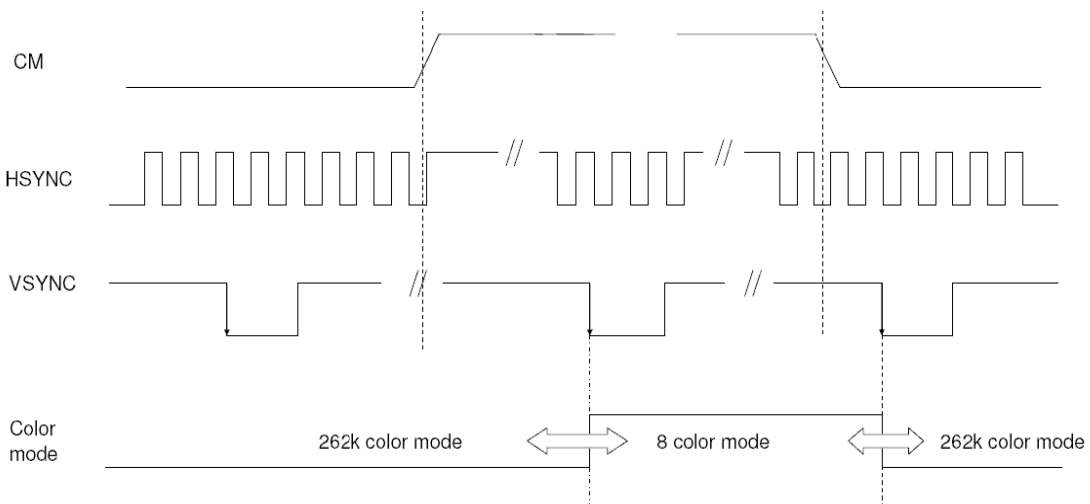

Figure 14. 3 Signal timing in DE mode



Note: The color mode conversion starts at the first falling edge of VSYNC after stage change of CM.

Figure 14. 4 Color mode conversion timing

2-4-2 CCIR601 Timing

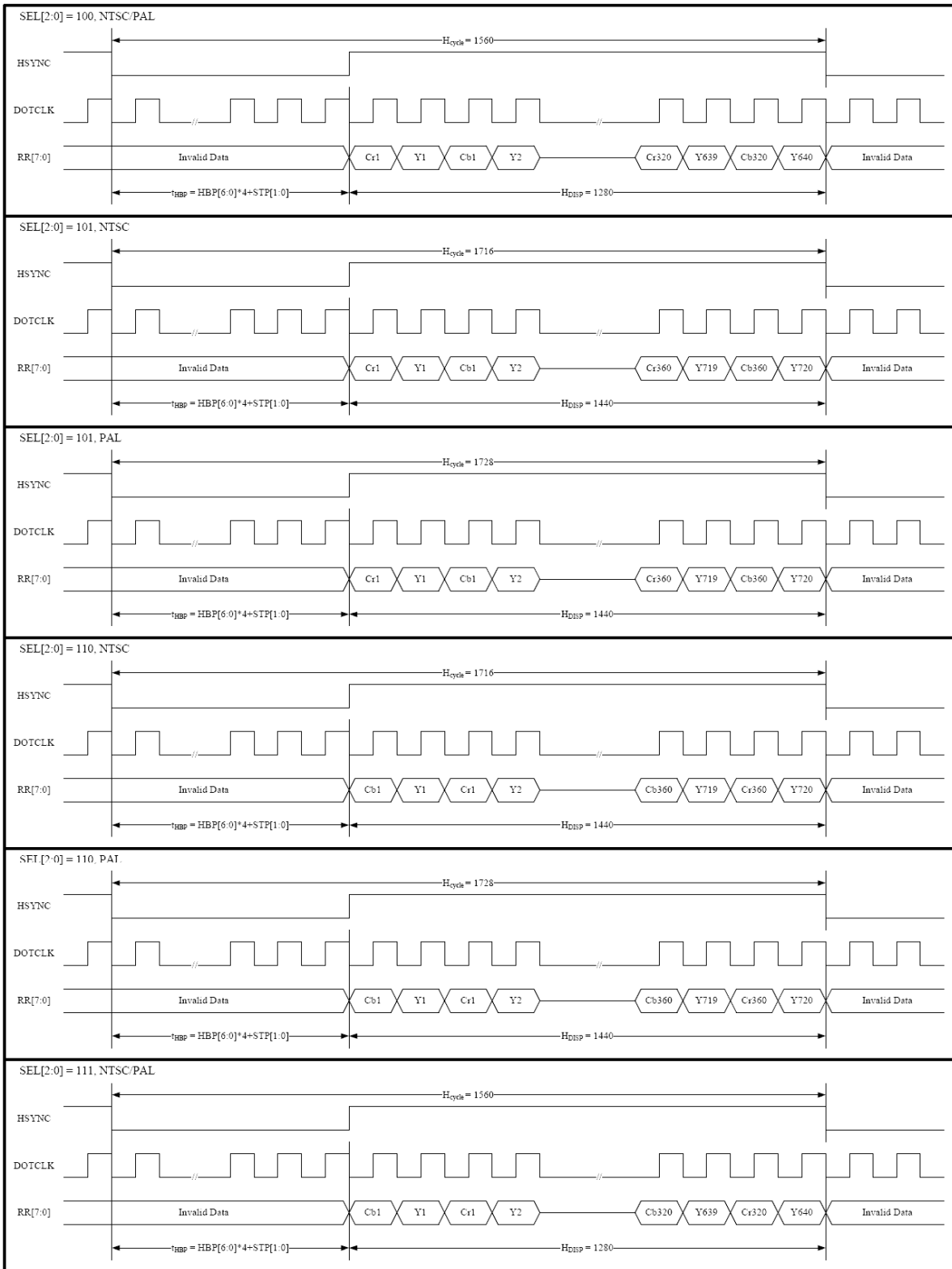

Figure 14. 5 CCIR601 horizontal timing

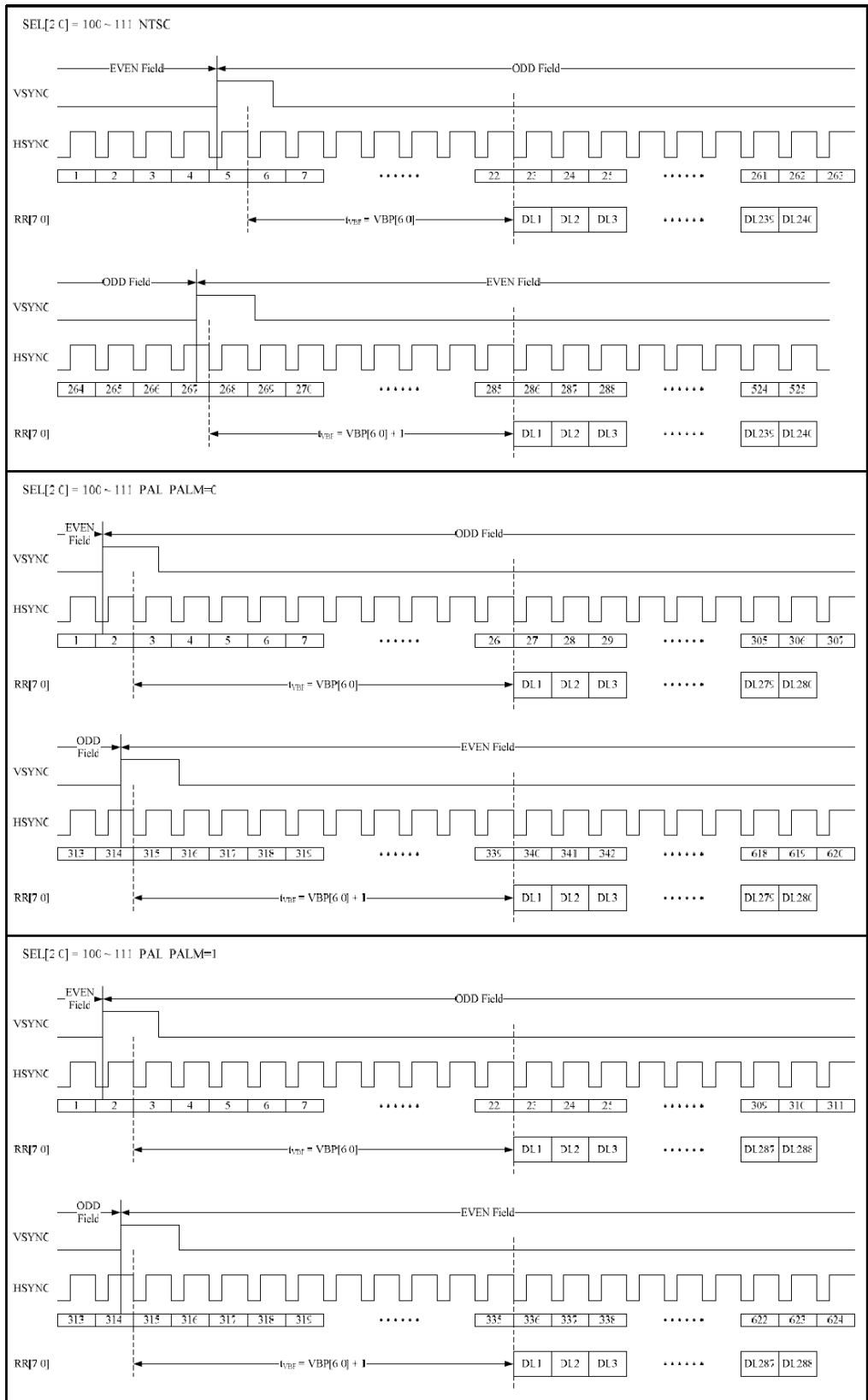

Figure 14. 6 CCIR601 vertical timing

2-4-3 CCIR656 Timing

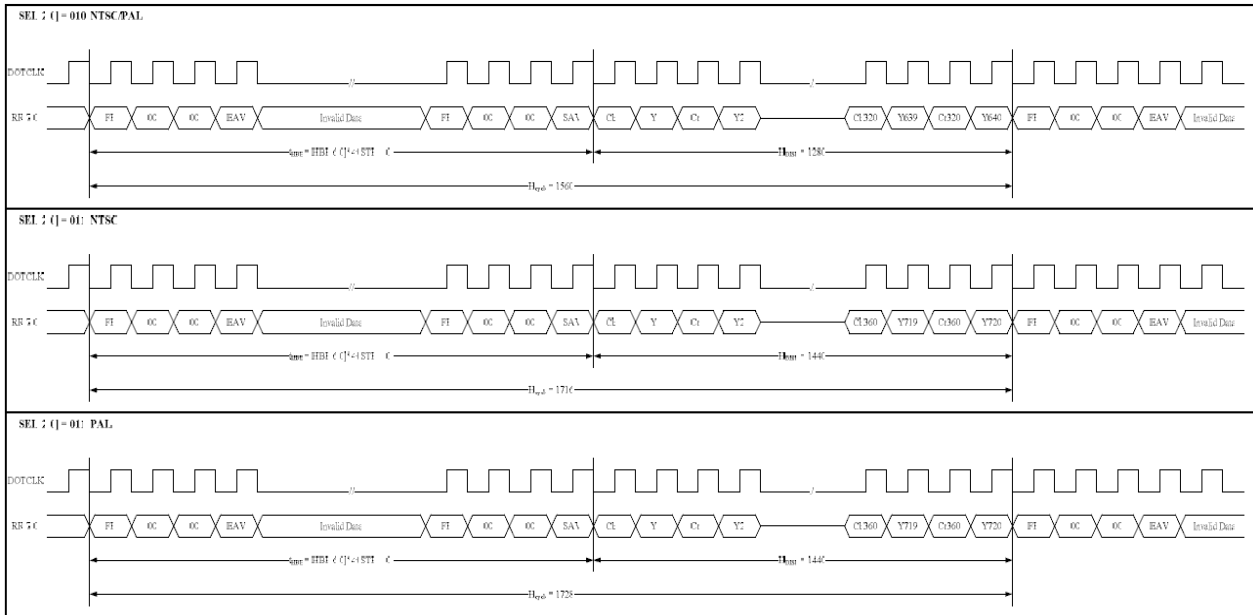

Figure 14. 7 CCIR656 horizontal timing

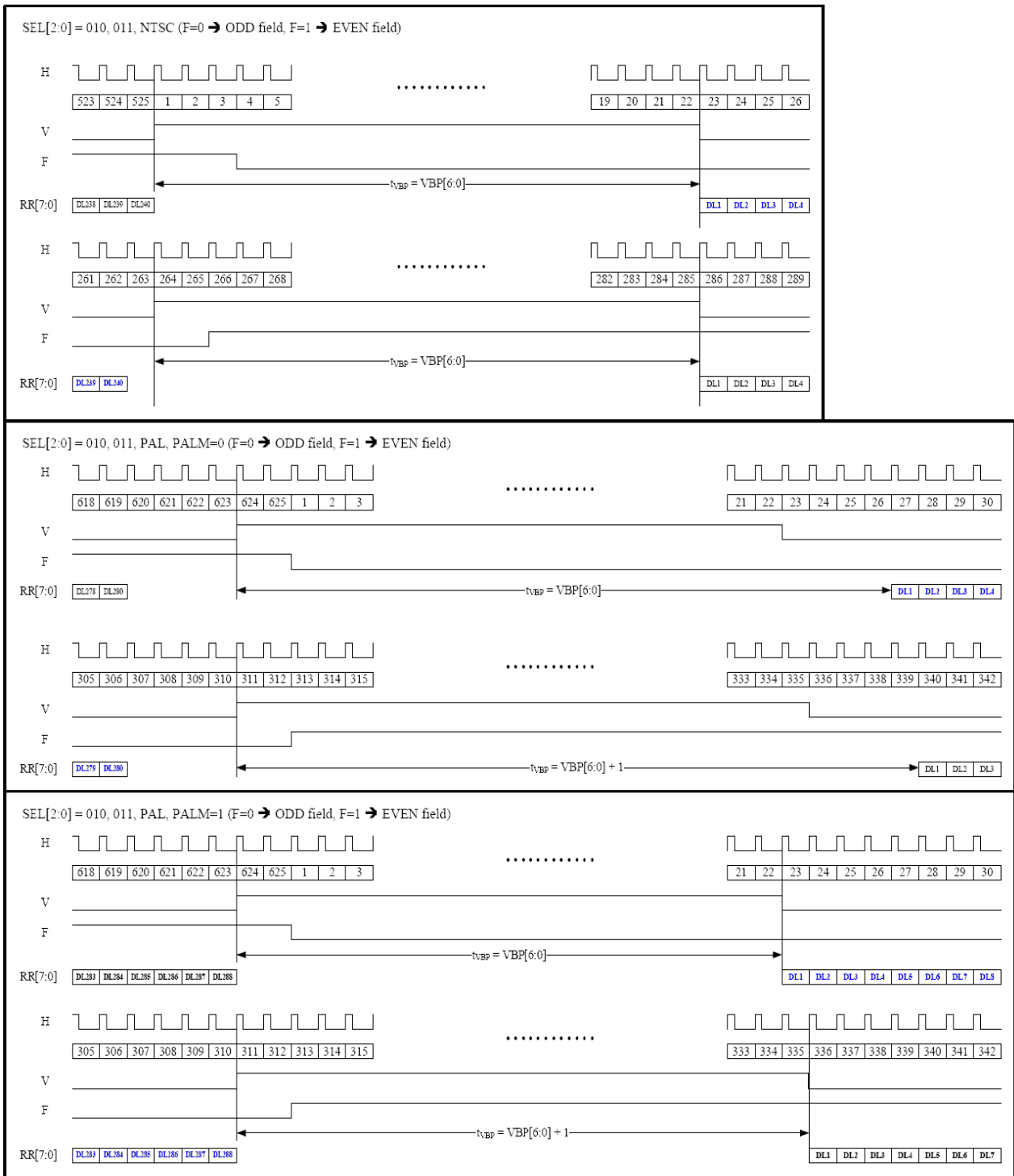

Figure 14. 8 CCIR656 vertical timing

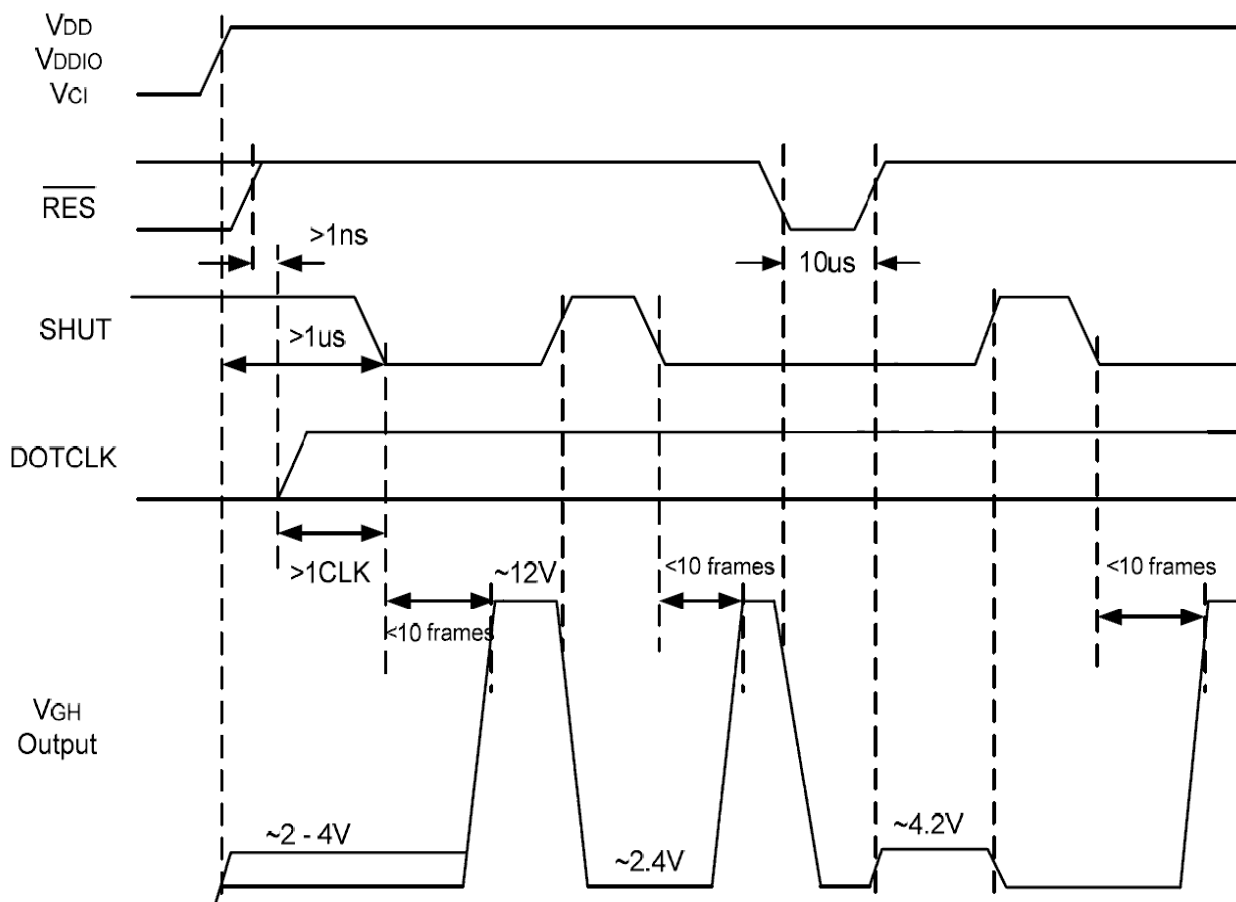

Figure 14. 9 VGH Output Against SHUT & RES

- Note:**
- (1) The minimum cycle time of SHUT is $10 + 2$ frames.
 - (2) DOTCLK must be provided for boosting of VGH. The above timing diagram assumed voltages and DOTCLK are continuous supplied after power on.
 - (3) VGH and VGL will be forced to VSS at the low stage of RESB.
 - (4) The minimum pulse width of RESB is 10us.

2-4-4 Power Up Sequence

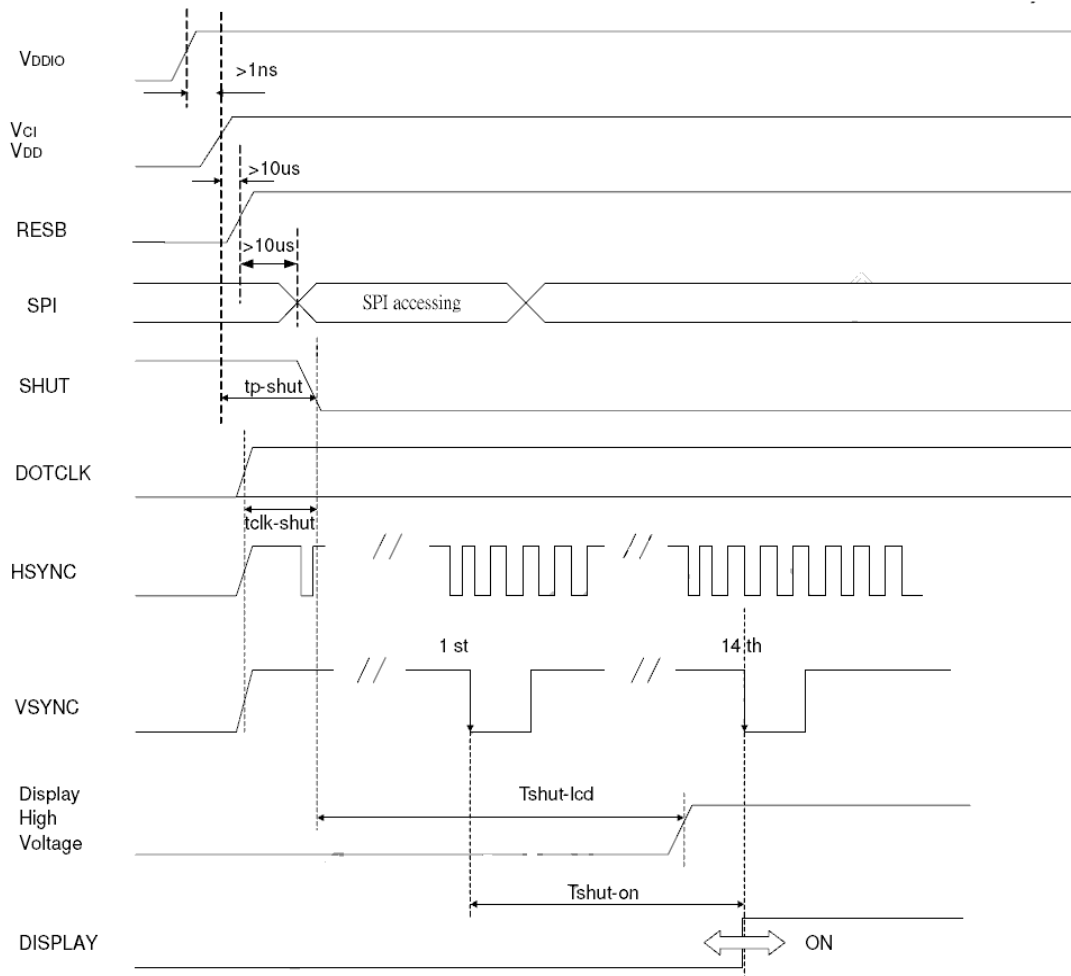

Figure 14. 10 Power Up Sequence

Characteristics	Symbol	Min	Typ	Max	Units
VDDD / VDDIO on to falling edge of SHUT	$t_{p\text{-shut}}$	1	-	-	us
DOTCLK	$t_{\text{clk-shut}}$	1	-	-	clk
Falling edge of SHUT to LCD power on	$t_{\text{shut-lcd}}$	-	-	128	ms
Falling edge of SHUT to display start	$t_{\text{shut-on}}$	-	-	14	frame
-1 line: 408 clk -1 frame: 282 line -DOTCLK = 7.5MHz		-	166	232.4	ms

Note: It is necessary to input DOTCLK before the falling edge of SHUT.

Display starts at 10th falling edge of VSTNC after the falling edge of SHUT.

Table 14. 3 Power Up Sequence

Date : Nov. 06, 2009

TECHNICAL SPECIFICATION

HYES

LCM

HT3503LH-T-01

Page 19 of 33

2-4-5 Power Down Sequence

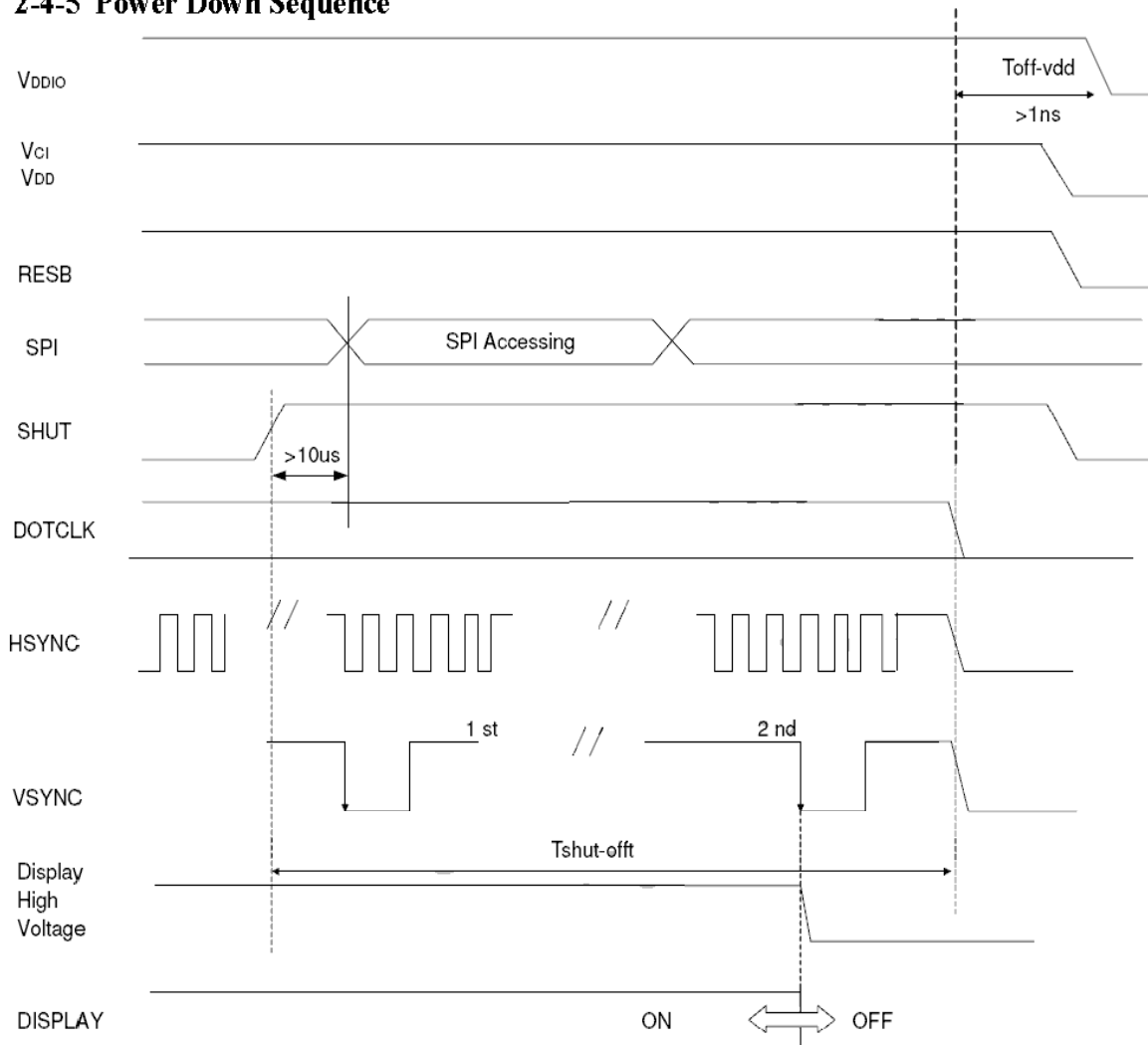

Figure 14. 11 Power Down Sequence

Characteristics	Symbol	Min	Typ	Max	Uni
Rising edge of SHUT to display off	tshut-off	2	-	-	frame
-1 line: 408 clk		33.4	-	-	ms
-1 frame: 262 line					
-DOTCLK = 7.5MHz					
Input-signal-off to VDDD / VDDIO off	toff-vdd	1	-	-	us

Note: DOTCLK must be maintained at least 2 frames after the rising edge of SHUT.

Display become off at the 2nd falling edge of VSTNC after the falling edge of SHUT.

If RESET signal is necessary for power down, provide it after the 2-frames-cycle of the SHUT period.

Table 14. 4 Power Down Sequence

2-4-6 SPI Timing

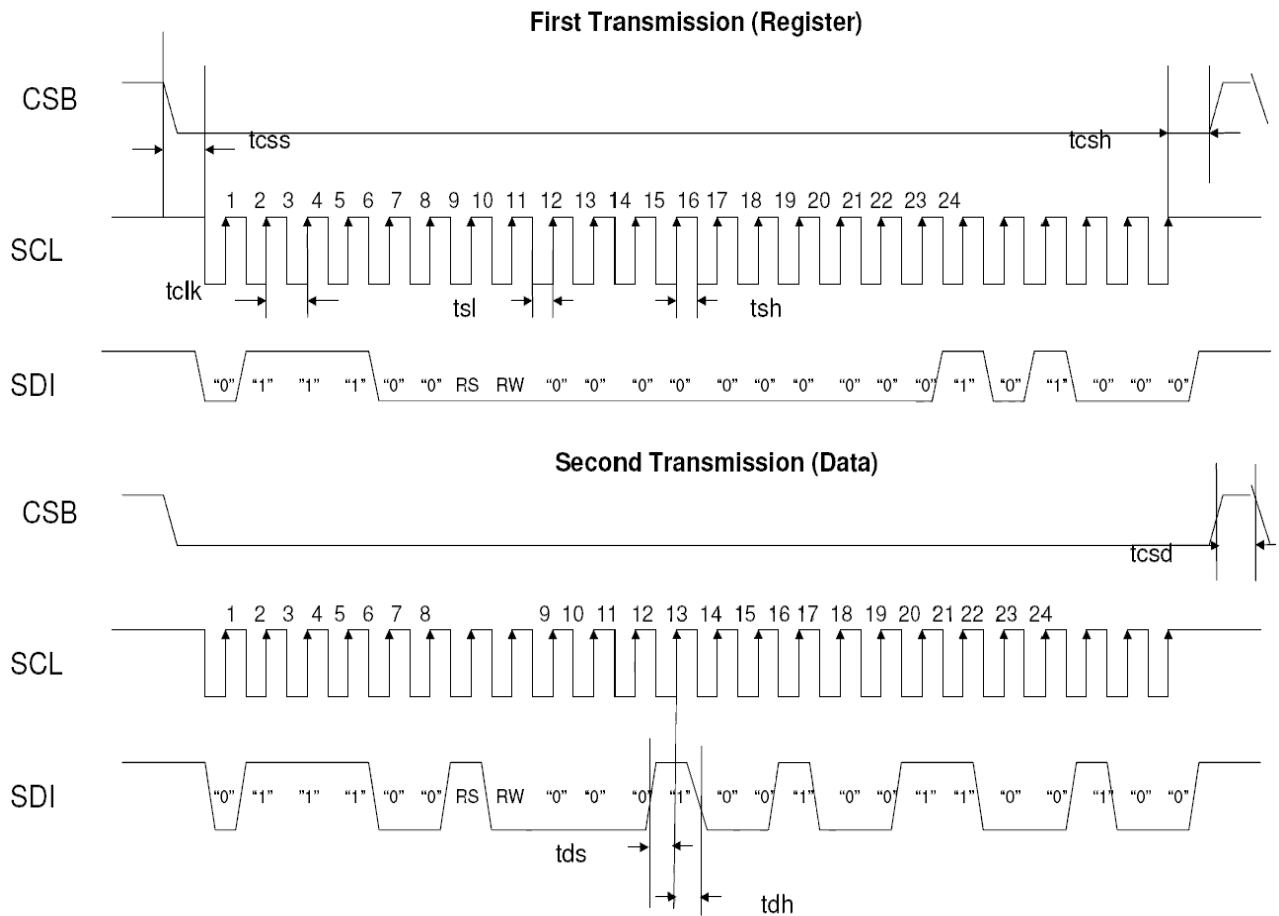

Note: The example transmit "0x1264h" to register R28h.
SPID connected to VSS.

Figure 14. 12 SPI interface Timing Diagram & Transaction Example

Characteristics	Symbol	Min	Typ	Max	Unit
Serial Clock Frequency	fclk	-	-	20	MHz
Serial Clock Cycle Time	tclk	50	-	-	ns
Clock Low Width	tsl	25	-	-	ns
Clock High Width	tsh	25	-	-	ns
Chip Select Setup Time	tcss	0	-	-	ns
Chip Select Hold Time	tcsh	10	-	-	ns
Chip Select High Delay Time	tcsh	20	-	-	ns
Data Setup Time	tds	5	-	-	ns
Data Hold Time	tdh	10	-	-	ns

Table 14. 5 SPI Timing

3. OPTICAL CHARACTERISTICS

3.1 Characteristics

Electrical and Optical Characteristics

No.	Item	symbol / temp	Min.	Typ.	Max.	Unit	Note		
1	Response Time	Tr	25 °C	-	15	ms	2		
		Tf	25 °C	-	35			50	
2	Viewing Angle	Hor.	Θ_{2+}	0°	45	60	degree	3	
			Θ_{2-}	180°	45	60			-
		Ver.	Θ_{1+}	270°	15	45			-
			Θ_{1-}	90°	35	60			-
3	Contrast Ratio	Cr	25 °C	400	800	-	4		
4	Red x-code	Rx	25 °C	0.58	0.63	0.68	-	5	
	Red y-code	Ry		0.31	0.36	0.41			
	Green x-code	Gx		0.30	0.35	0.40			
	Green y-code	Gy		0.54	0.59	0.64			
	Blue x-code	Bx		0.09	0.14	0.19			
	Blue y-code	By		0.05	0.10	0.15			
	White x-code	Wx		0.28	0.33	0.38			
	White y-code	Wy		0.31	0.36	0.41			
	Brightness	Y		400	560	-			cd/m ²
5	Brightness Uniformity		25 °C	80	-	-	%	6	

3.2 Definition of optical characteristics

Measurement condition :

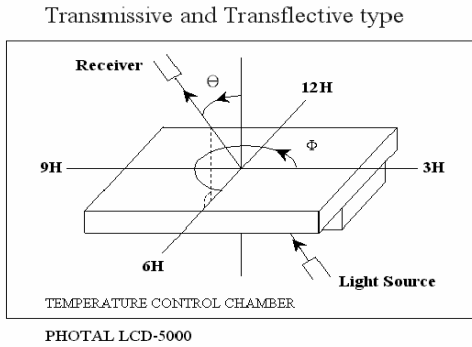

[Note 1] Definition of LCD Driving Vop and Waveform :

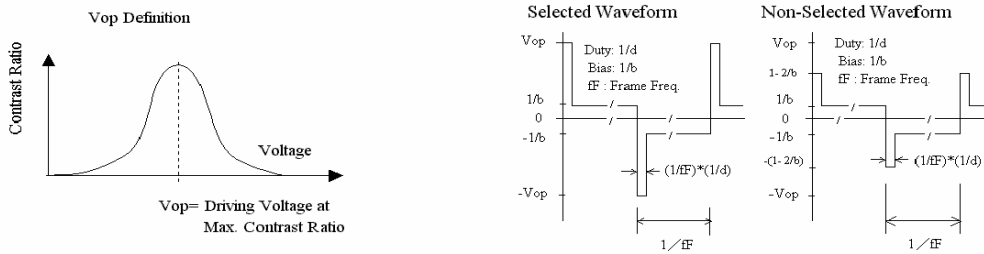

[Note 2] Definition of Response Time

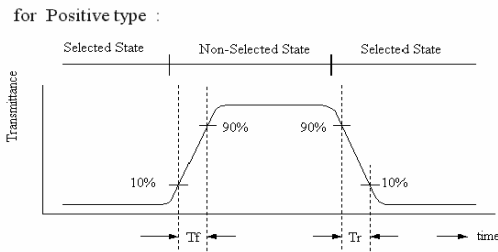

[Note 3] Definition of Viewing Angle :

[Note 4] Definition of Contrast Ratio :

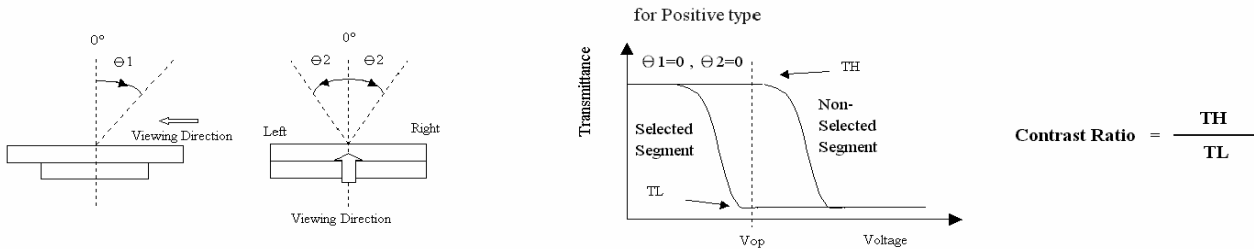

Date : Nov. 06, 2009

TECHNICAL SPECIFICATION

HYES

LCM

HT3503LH-T-01

Page 23 of 33

[Note 5] Definition of measurement of Color Chromaticity and Brightness

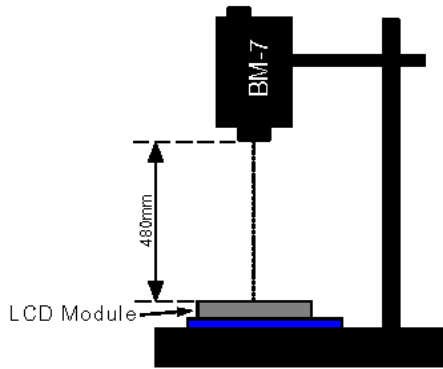

[Note 6] Definition of Brightness Uniformity

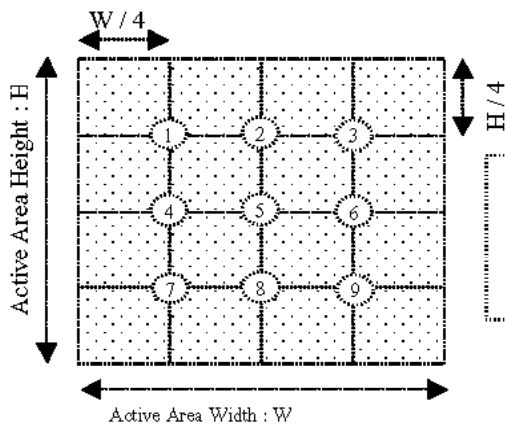

$$\text{Brightness Uniformity} = \frac{\text{Minimum Brightness of Point 1~9}}{\text{Maximum Brightness of Point 1~9}}$$

[Note 7] Definition of Measurement of Reflectance

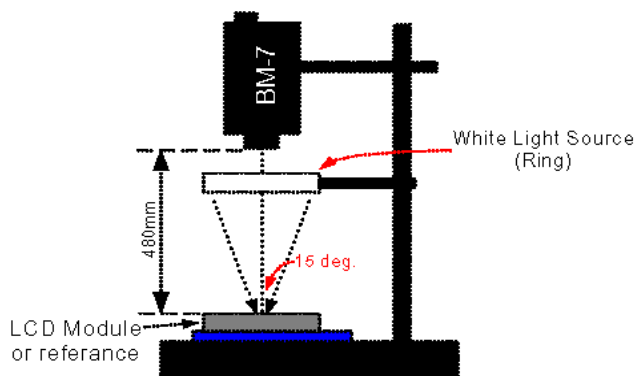

4. RELIABILITY :

Item No	Items	Condition
1	High temperature operating	70 °C , 200 hours
2	Low temperature operating	-20 °C , 200 hours
3	High temperature storage	80 °C , 200 hours
4	Low temperature storage	-30 °C , 200 hours
5	High temperature & humidity storage	60°C, 90%RH, 100 hours
6	Thermal Shock storage	-30°C, 30min.<=> 80°C, 30min. 10 Cycles
7	Vibration test	10 => 55 =>10 => 55 => 10 Hz , within 1 minute Amplitude : 1.5mm. 15 minutes for each Direction (X,Y,Z)
8	Drop test	Packed, 100CM free fall, 6 sides, 1 corner, 3edges
9	Life time	50,000 hours 25°C , 70%RH below , specification condition driving

- * One single product test for only one item.
- * Judgment after test : keep in room temperature for more than 2 hours.
 - Current consumption < 2 times of initial value
 - Contrast > 1/2 initial value
 - Function : work normally

5. PRODUCT HANDLING AND APPLICATION

PRECAUTION FOR HANDLING LCM

- The LCD module contains a C-MOS LSI. People who operate the LCM should wear ESD protection equipment to prevent ESD hurt on products.
- Do not input any signal before power is turned on.
- Do not take LCM from its packaging bag until it is assembled.
- Peel off the LCM protective film slowly since static electricity may be generated.
- Pay attention to the humidity of the work shop, 50~60%RH is satisfactory.
- Use a non-leak iron for soldering LCM.
- Do not touch the display surface or connection terminals area with bare hands. Smudges on the display surface reduce the insulation between terminals.
- Cautions for soldering to LCM:
 Condition for soldering I/O terminals:
 Temperature at iron tip :280°C±10°C.
 Soldering time : 3~4sec./ terminals.
 Type of solder : Eutectic solder(rosin flux filled).

PRECAUTION IN USE OF LCD

- Do not contact or scratch the front surface and the contact pads of a LCD panel with hard materials such as metal or glass or with one's nail.
- To clean the surface , wipe it gently with soft cloth dampened by alcohol.
- Do not attempt to wipe off the contact pads.
- Keep LCD panels away from direct sunlight , also avoid them in high-temperature & high humidity environment for a long period.
- Do not drive LCD panels by DC voltage.
- Do not expose LCD panels to organic solvent.
- Liquid in LCD is hazardous substance. In case a contact with liquid crystal material is occurred, be sure to immediately wash such material away by soap and water.
- The polarizer is easily damaged and should be handle with special care. Don't press or rub it with hard objects.

PRECAUTION FOR STORING LCM

- To avoid degradation of the device , do not store the module under the conditions of direct sunlight , high temperature or high humidity . Keep the module in bags designed to prevent static electricity charging under low temperature / normal humidity conditions(avoid high temperature / high humidity and low temperature below 0°C)

USING ON MEDICAL CARE , SAFETY OR HAZARDOUS APPLICATION OR SYSTEM

- For the application in medical care, safety and hazardous products or systems, an authorization from **HYES** is required. **HYES** will not responsible for any damage or loss which caused by the products without any authorization given by **HYES**.
- This product is not allowed to be designed and used for military application and/or purpose.
- The delivery of this product to the countries and/or regions where the embargoes are imposed by U.N. is prohibited.
- The application and delivery of this product must comply with Startegic High-Tech Commodities (SHTC) export control and the sales to the embargoed and/or sanctioned countries or regions are strictly prohibited.

Date : Nov. 06, 2009

TECHNICAL SPECIFICATION

HYES

LCM

HT3503LH-T-01

Page 26 of 33

6. DATE CODE OF PRODUCTS

- Date code will be shown on each product :

- **Y MM DD - XXX**

Year Month Day - Production lots

- Example: 2 1 2 2 3 - 0 0 3 ==> Year 2002, Dec.,23rd , Batch no.03

7. PACKING

Instruction of lot number:

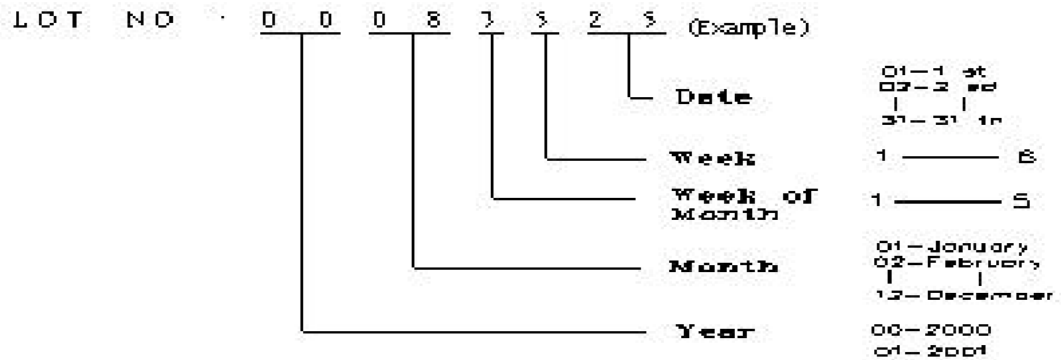

Label of carton:

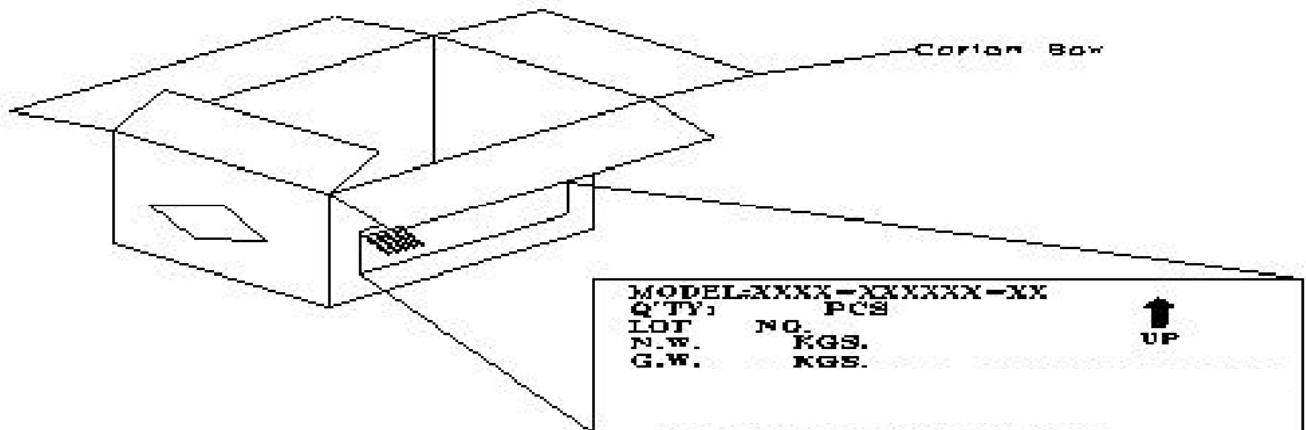

Packing tray must be stacked with alternated direction to each others.
 To tacks packing trays in same direction will cause product damaged.

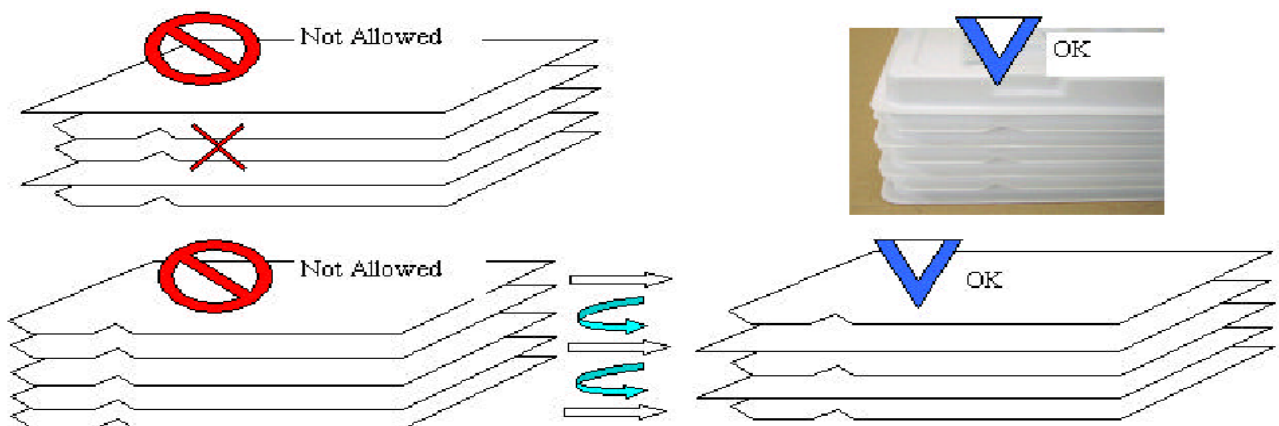

Date : Nov. 06, 2009

TECHNICAL SPECIFICATION

HYES

LCM

HT3503LH-T-01

Page 28 of 33

NOTE:

- T.B.D pcs / Tray
- T.B.D Tray / Box
- T.B.D Box / Carton
- T.B.D pcs / Carton

- (1) Be warned, the direction of the tray has to turn it by 180 degree before stack it up. Otherwise, it will be packager's responsibility!!
- (2) Safe Stack : 5 cartons only

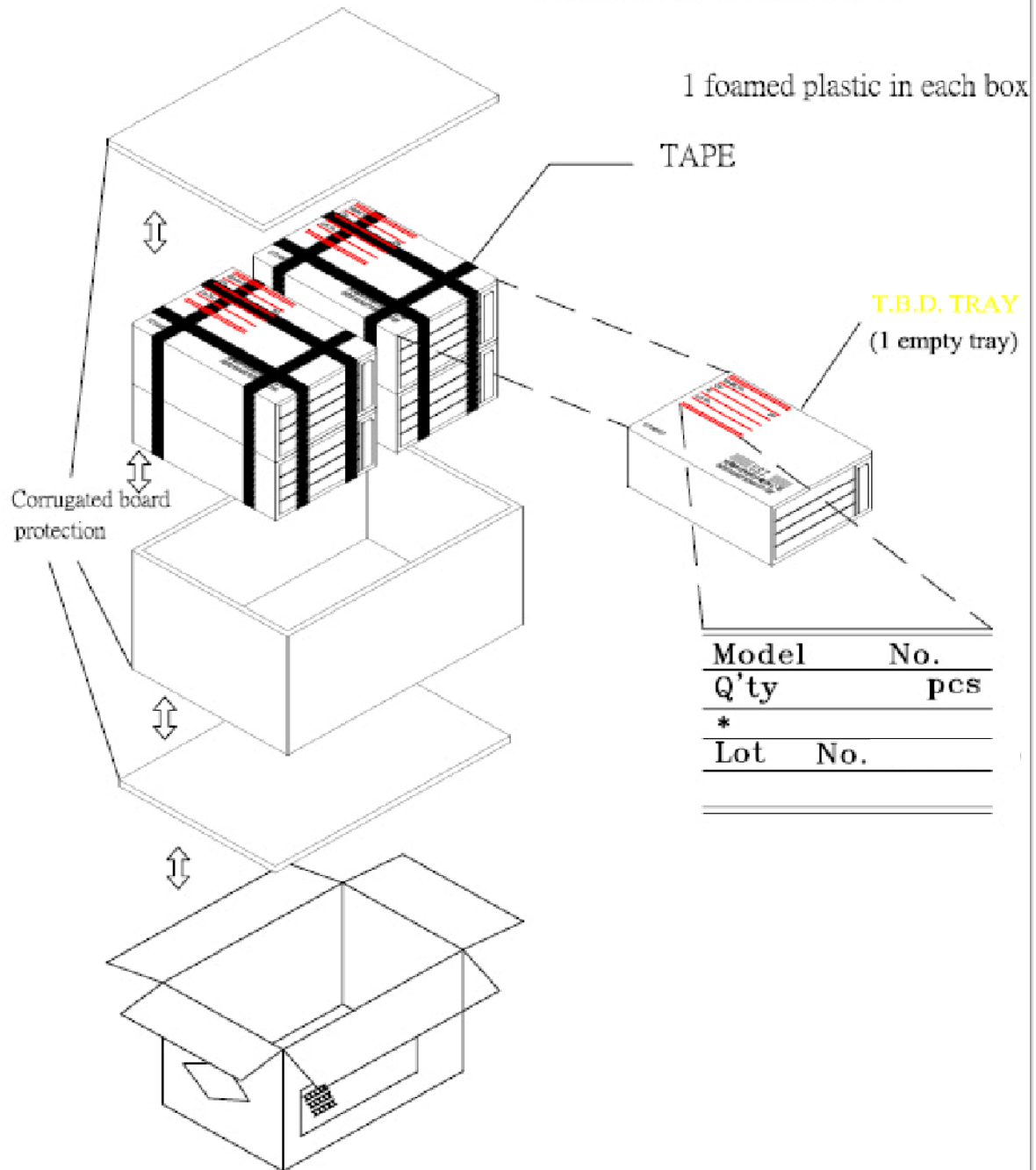

Date : Nov. 06, 2009

TECHNICAL SPECIFICATION

HYES

LCM

HT3503LH-T-01

Page 29 of 33

8. INSPECTION STANDARD

8.1. QUALITY :

THE QUALITY OF GOODS SUPPLIED TO PURCHASER SHALL COME UP TO THE FOLLOWING STANDARD.

8.1.1. THE METHOD OF PRESERVING GOODS

AFTER DELIVERY OF GOODS FROM **HYES** TO PURCHASER. PURCHASER SHALL CONTROL THE LCM AT -10 °C ~ 40 °C ,AND IT MIGHT BE DESIRABLE TO KEEP AT THE NORMAL ROOM TEMPERATURE AND HUMIDITY UNTIL INCOMING INSPECTION OR THROWING INTO PROCESS LINE.

8.1.2. INCOMING INSPECTION

(A) THE METHOD OF INSPECTION

IF PURCHASER MAKE AN INCOMING INSPECTION , A SAMPLING PLAN SHALL BE APPLIED ON THE CONDITION THAT QUALITY OF ONE DELIVERY SHALL BE REGARDED AS ONE LOT.

(B) THE STANDARD OF QUALITY

ISO-2859-1 (or MIL-STD-105D), LEVEL II SINGLE PLAN.

CLASS	AQL(%)
CRITICAL	0.4 %
MAJOR	0.65 %
MINOR	1.5 %
TOTAL	1.5 %

EVERY ITEM SHALL BE INSPECTED ACCORDING TO THE CLASS.

(C) MEASURE

IF AS THE RESULT OF ABOVE RECEIVING INSPECTION , A LOT OUT IS DISCOVERED.

PURCHASER SHALL BE INFORM SELLER OF IT WITHIN SEVEN DAYS. BUT FIRST SHIPMENT WITHIN FOURTEEN DAYS.

8.1.3. WARRANTY POLICY

HYES WILL PROVIDE ONE-YEAR WARRANTY FOR THE PRODUCTS ONLY IF UNDER SPECIFICATION OPERATING CONDITIONS. **HYES** WILL REPLACE NEW PRODUCTS FOR THESE DEFECT PRODUCTS WHICH UNDER WARRANTY PERIOD AND BELONG TO THE RESPONSIBILITY OF **HYES** .

8.2. CHECKING CONDITION

8.2.1. CHECKING DIRECTION SHALL BE IN THE 45 DEGREE AREA TO FACE THE SAMPLE.

8.2.2. CHECKER SHALL SEE OVER 30 cm. WITH BARE EYES FAR FROM SAMPLE AND USING 2 PCS. OF 20W FLUORESCENT LAMP.

Date : Nov. 06, 2009

TECHNICAL SPECIFICATION

HYES

LCM

HT3503LH-T-01

Page 30 of 33

8.3. INSPECTION PLAN :

CLASS	ITEM	JUDGEMENT	CLASS
PACKING & INDICATE	1. OUTSIDE AND INSIDE PACKAGE	"MODEL NO.", "LOT NO." AND "QUANTITY" SHOULD INDICATE ON THE PACKAGE.	Minor
	2. MODEL MIXED AND QUANTITY	OTHER MODEL MIXED.....REJECTED QUANTITY SHORT OR OVER.....REJECTED	Critical
	3. PRODUCT INDICATION	"MODEL NO." SHOULD INDICATE ON THE PRODUCT	Major
ASSEMBLY	4. DIMENSION, LCD GLASS SCRATCH AND SCRIBE DEFECT.	ACCORDING TO SPECIFICATION OR DRAWING.	Major
APPEARANCE	5. VIEWING AREA	POLARIZER EDGE OR LCD'S SEALING LINE IS VISABLE IN THE VIEWING AREAREJECTED	Minor
	6. BLEMISH - BLACK SPOT - WHITE SPOT IN THE LCD AND LCD GLASS CRACKS	ACCORDING TO STANDARD OF VISUAL INSPECTION (INSIDE VIEWING AREA)	Minor
	7. BLEMISH - BLACK SPOT WHITE SPOT AND SCRTCH ON THE POLARIZER	ACCORDING TO STANDARD OF VISUAL INSPECTION (INSIDE VIEWING AREA)	Minor
	8. BUBBLE IN POLARIZER	ACCORDING TO STANDARD OF VISUAL INSPECTION (INSIDE VIEWING AREA)	Minor
	9. LCD'S RAINBOW COLOR	STRONG DEVIATION COLOR (OR NEWTON RING) OF LCD.....REJECTED. OR ACCORDING TO LIMITED SAMPLE (IF NEEDED, AND INSIDE VIEWING AREA)	Minor
ELECTRICAL	10. ELECTRICAL AND OPTICAL CHARACTERISTICS (CONTRAST - VOP - CHROMATICITY ... ETC)	ACCORDING TO SPECIFICATION OR DRAWING . (INSIDE VIEWING AREA)	Critical
	11. MISSING PATTERN	MISSING DOT - LINE - CHARACTERREJECTED	Critical
	12. SHORT CIRCUIT - WRONG PATTERN DISPLAY	NON DISPLAY - WRONG PATTERN DISPLAY - CURRENT CONSUMPTION OUT OF SPECIFICATION..... REJECTED	Critical
	13. PIN HOLE - PATTERN DEFORMITY	ACCORDING TO STANDARD OF VISUAL INSPECTION	Minor

Date : Nov. 06, 2009

TECHNICAL SPECIFICATION

HYES

LCM

HT3503LH-T-01

Page 31 of 33

8.4. STANDARD OF VISUAL INSPECTION

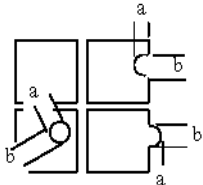
NO.	CLASS	ITEM	JUDGEMENT																									
8.4.1	MINOR	· BLEMISH · BLACK SPOT · WHITE SPOT IN THE LCD. · BLEMISH · BLACK SPOT · WHITE SPOT AND SCRATCH ON THE POLARIZER	(A) ROUND TYPE: unit : mm. <table border="1" style="width: 100%;"> <thead> <tr> <th>DIAMETER (mm.)</th> <th>ACCEPTABLE Q'TY</th> </tr> </thead> <tbody> <tr> <td>$\Phi \leq 0.1$</td> <td>DISREGARD</td> </tr> <tr> <td>$0.1 < \Phi \leq 0.2$</td> <td>2</td> </tr> <tr> <td>$0.2 < \Phi \leq 0.25$</td> <td>1</td> </tr> <tr> <td>$0.25 < \Phi$</td> <td>0</td> </tr> </tbody> </table> NOTE: $\Phi = (\text{LENGTH} + \text{WIDTH}) / 2$ (B) LINER TYPE: unit : mm. <table border="1" style="width: 100%;"> <thead> <tr> <th>LENGTH</th> <th>WIDTH</th> <th>ACCEPTABLE Q'TY</th> </tr> </thead> <tbody> <tr> <td>-----</td> <td>$W \leq 0.03$</td> <td>DISREGARD</td> </tr> <tr> <td>$L \leq 5.0$</td> <td>$0.03 < W \leq 0.05$</td> <td>3</td> </tr> <tr> <td>$L \leq 5.0$</td> <td>$0.05 < W \leq 0.07$</td> <td>1</td> </tr> <tr> <td>-----</td> <td>$0.07 < W$</td> <td>FOLLOW ROUND TYPE</td> </tr> </tbody> </table>	DIAMETER (mm.)	ACCEPTABLE Q'TY	$\Phi \leq 0.1$	DISREGARD	$0.1 < \Phi \leq 0.2$	2	$0.2 < \Phi \leq 0.25$	1	$0.25 < \Phi$	0	LENGTH	WIDTH	ACCEPTABLE Q'TY	-----	$W \leq 0.03$	DISREGARD	$L \leq 5.0$	$0.03 < W \leq 0.05$	3	$L \leq 5.0$	$0.05 < W \leq 0.07$	1	-----	$0.07 < W$	FOLLOW ROUND TYPE
DIAMETER (mm.)	ACCEPTABLE Q'TY																											
$\Phi \leq 0.1$	DISREGARD																											
$0.1 < \Phi \leq 0.2$	2																											
$0.2 < \Phi \leq 0.25$	1																											
$0.25 < \Phi$	0																											
LENGTH	WIDTH	ACCEPTABLE Q'TY																										
-----	$W \leq 0.03$	DISREGARD																										
$L \leq 5.0$	$0.03 < W \leq 0.05$	3																										
$L \leq 5.0$	$0.05 < W \leq 0.07$	1																										
-----	$0.07 < W$	FOLLOW ROUND TYPE																										
8.4.2	MINOR	BUBBLE IN POLARIZER	unit : mm. <table border="1" style="width: 100%;"> <thead> <tr> <th>DIAMETER</th> <th>ACCEPTABLE Q'TY</th> </tr> </thead> <tbody> <tr> <td>$\Phi \leq 0.15$</td> <td>DISREGARD</td> </tr> <tr> <td>$0.15 < \Phi \leq 0.5$</td> <td>2</td> </tr> <tr> <td>$0.5 < \Phi$</td> <td>0</td> </tr> </tbody> </table>	DIAMETER	ACCEPTABLE Q'TY	$\Phi \leq 0.15$	DISREGARD	$0.15 < \Phi \leq 0.5$	2	$0.5 < \Phi$	0																	
DIAMETER	ACCEPTABLE Q'TY																											
$\Phi \leq 0.15$	DISREGARD																											
$0.15 < \Phi \leq 0.5$	2																											
$0.5 < \Phi$	0																											
8.4.3	MINOR	PIN HOLE · PATTERN DEFORMITY	unit : mm.  <table border="1" style="width: 100%;"> <thead> <tr> <th>DIAMETER</th> <th>ACC. Q'TY</th> </tr> </thead> <tbody> <tr> <td>$\Phi \leq 0.1$</td> <td>DISREGARD</td> </tr> <tr> <td>$0.1 < \Phi \leq 0.25$</td> <td>3</td> </tr> <tr> <td>$0.25 < \Phi$</td> <td>0</td> </tr> </tbody> </table> <p style="text-align: center;">$\Phi = (a+b)/2$</p>	DIAMETER	ACC. Q'TY	$\Phi \leq 0.1$	DISREGARD	$0.1 < \Phi \leq 0.25$	3	$0.25 < \Phi$	0																	
DIAMETER	ACC. Q'TY																											
$\Phi \leq 0.1$	DISREGARD																											
$0.1 < \Phi \leq 0.25$	3																											
$0.25 < \Phi$	0																											

Date : Nov. 06, 2009

TECHNICAL SPECIFICATION

HYES

LCM

HT3503LH-T-01

Page 32 of 33

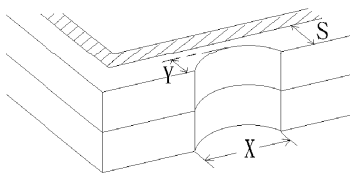
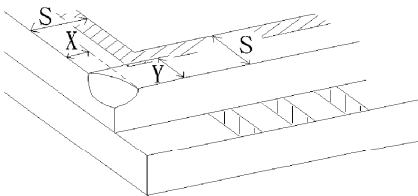
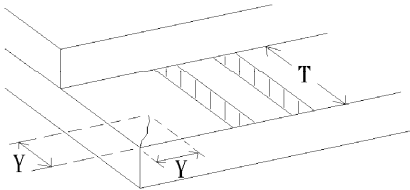
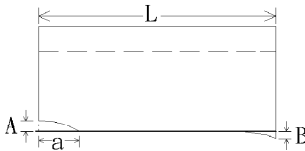
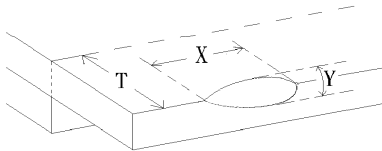
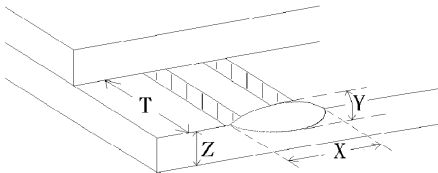
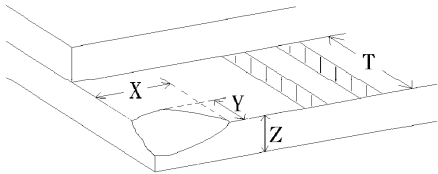
NO.	CLASS	ITEM	JUDGEMENT
8.4.4	MINOR	CHIPPING	 $Y > S$ REJ.
8.4.5	MINOR	CHIPPING	 $X \text{ or } Y > S$ REJ.
8.4.6	MAJOR	GLASS CRACK	 $Y > (1/2) T$ REJ.
8.4.7	MAJOR	SCRIBE DEFECT	 <p>1. $a > L/3$, $A > 1.5\text{mm}$. REJ.</p> <p>2. B : ACCORDING TO DIMENSION</p>
8.4.8	MINOR	CHIPPING (ON THE TERMINAL AREA)	 $\Phi = (x+y)/2 > 2.5 \text{ mm}$ REJ.
8.4.9	MINOR	CHIPPING (ON THE TERMINAL SURFACE)	 $Y > (1/3) T$ REJ.
8.4.10	MINOR	CHIPPING	 $Y > T$ REJ.

Date : Nov. 06, 2009

TECHNICAL SPECIFICATION

HYES

LCM

HT3503LH-T-01

Page 33 of 33