

APPROVAL

PART NO.	DESCRIPTION	REMARKS
HT5702UL	LCD MODULE (320 × RGB × 240)	* This is ROHS compliant

CUSTOMER APPLICATION P/N	
APPROVED BY	
DATE	

PLEASE KINDLY FIND AND APPROVE THE SPECIFICATIONS INSERTED
HEREIN AND RETURN ONE COPY HERE OF WITH YOUR SIGNATURE OF APPROVAL.

PERPARED BY	CHECKED BY	CONFIRMED BY



HYES Optoelectronics, Inc.

2000 Wyatt Drive Suite 6
Santa Clara, CA 95054 USA

CONTENTS:

No.	Item
1	BASIC SPECIFICATION 1.1 Mechanical Specification 1.2 Display Specification 1.3 Outline Dimension 1.4 Block Diagram 1.5 Interface Pin
2	ELECTRICAL CHARACTERISTICS 2.1 Absolute Maximum Ratings 2.2 DC Characteristics 2.3 AC Characteristics 2.4 Interface Timing Chart
3	OPTICAL CHARACTERISTICS 3.1 Condition 3.2 Definition of Optical Characteristics
4	RELIABILITY
5	PRODUCT HANDING AND APPLICATION
6	DATECODE
7	PACKING & LOTNO
8	INSPECTION STANDARD

1. BASIC SPECIFICATION

1.1 Mechanical specifications

Items	Nominal Dimension	Unit
Dot Matrix	320*RGB*240	dots
Module Size (W x H x T)	154.6 x 114.8 x 8.5	mm.
Viewing Area (W x H)	116.2 x 87.4	mm.
Active Area (W x H)	115.2 x 86.4	mm.
Dot Size (W x H)	0.36 x 0.36	mm.
Driving IC Package	COG	

1.2 Display specification

Display	Descriptions	Note
LCD Type	5.7" TFT	
LCD Mode	Normal white	
Polarizer Mode	Transmissive	
Polarizer UV-Cutting	With	
Polarizer Surface	Normal	
Background Color	Black	
Backlight Type	LED	
Backlight Color	White	
Viewing Direction	12 O'clock Direction	

* Color tone is slightly changed by temperature and driving voltage.

1.3 Outline dimension

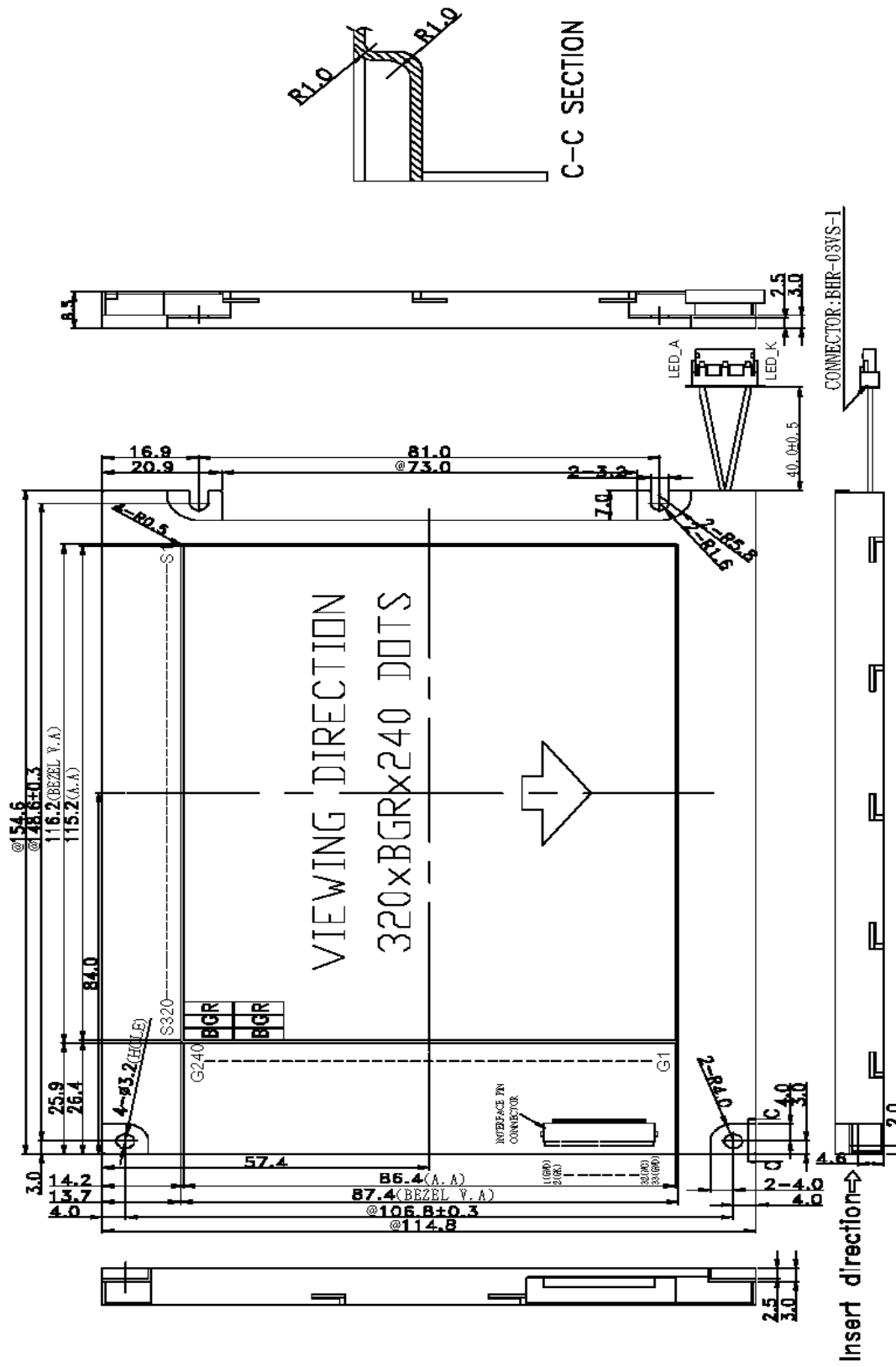

- NOTE:
- 1.LCD: TFT, TRANSMISSIVE MODE, NORMAL WHITE
 - 2.VIEWING DIRECTION: 12 O'CLOCK
 - 3.TOP: -20°C~70°C; TST: -30°C~80°C
 - 4.DRIVER IC: HX8218-A+HX8615-A
 - 5.TOLERANCE FOR NOT ASSIGNED: ±0.5 mm
 - 6."@": KEY DIMENSIONS
 - 7.TFT PIXEL SIZE: 120 x 360 um
 - 8.LED BACKLIGHT CONNECTORS: BHR-03VS-1
 - MATCHING CONNECTOR: SM02(8.0)B-BHS-1-TB(LF)(SN)
 - 9.INTERFACE PIN CONNECTOR: IMSA-9637S-33A-TB
 - 10.LED-COLOR: WHITE; VLED=23.1V(TYP),IF=60.0mA(Constant Current)

Date : Feb. 28, 2007

TECHNICAL SPECIFICATION

HYES

LCM

HT5702UL

Page 4 of 21

1.4 Block diagram:

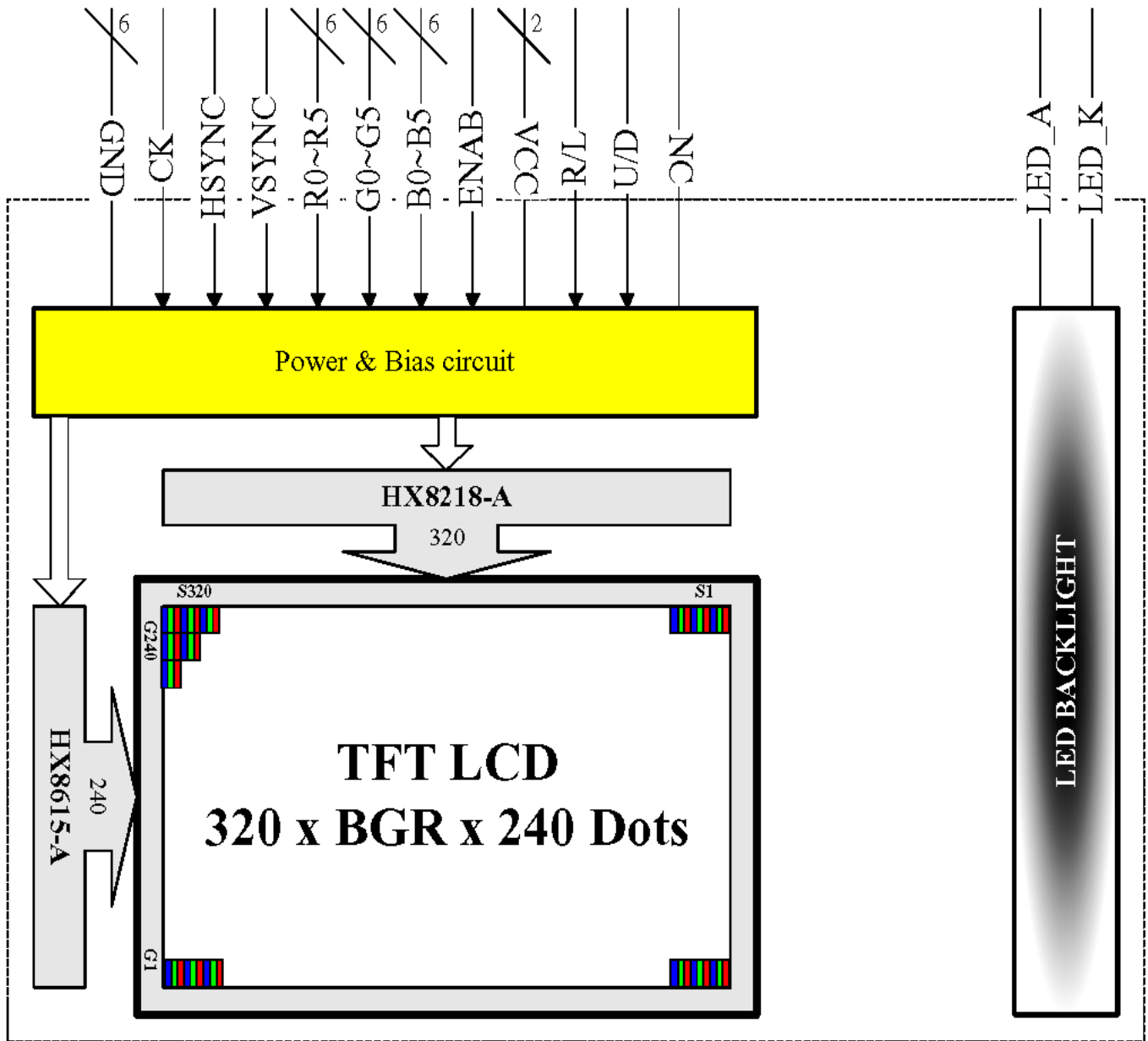

Date : Feb. 28, 2007

TECHNICAL SPECIFICATION

HYES

LCM

HT5702UL

Page 5 of 21

1.5 Interface pin :

Pin No.	Pin Symbol	I/O	Description
1	GND	P	Ground. (0V)
2	CK	I	Clock signal for sampling each data signal.
3	Hsync	I	Horizontal synchronous signal (Negative)
4	Vsync	I	Vertical synchronous signal (Negative)
5	GND	P	Ground. (0V)
6-11	R0-R5	I	RED data signal.
12	GND	P	Ground. (0V)
13-18	G0-G5	I	GREEN data signal.
19	GND	I	Ground. (0V)
20-25	B0-B5	I	BLUE data signal.
26	GND	I	Ground. (0V)
27	ENAB	I	Signal to settle the horizontal display position (Positive).
28,29	VCC	P	+3.3V power supply.
30	R/L	I	Horizontal display mode select signal. L: Normal, H: Rreverse.
31	U/D	I	Vertical display mode select signal. L: Normal, H: Rreverse.
*32	NC	-	No connect.
33	GND	P	Ground. (0V)

*This pin doesn't support the V/Q mode as the NO.32 pin of sharp spec.

1	LED_A	P	Power supply input pin for backlight.
2	LED_K	P	Ground pin for backlight.

2. ELECTRICAL CHARACTERISTICS

2.1 Absolute Maximum Ratings

Items	Symbol	Min.	Max.	Unit
Power supply voltage	VCC	-0.3	7.0	V
Power supply voltage	VDD	-0.3	7.0	V
Power supply voltage	VGH	-0.3	32.0	V
Power supply voltage	VEE	-22.0	0.3	V
Power supply voltage	VGH-VEE	-0.3	45.0	V
Logic Output Voltage	V _{out}	-0.3	7.0	V
Input voltage	V _{in}	-0.3	VDD+0.3	V
Operate temperature range	T _{OP}	-20	70	°C
Storage temperature range	T _{ST}	-30	80	°C

2.2 DC Characteristics

Items	Symbol	Condition	Min.	Typ.	Max.	Unit
Supply voltage (Logic)	V _{CC}	-	3.0	3.3	3.6	V
Input Voltage	V _L	L level	0	-	0.3 V _{CC}	V
	V _H	H level	0.7 V _{CC}	-	V _{CC}	V
LCM Recommend LCD	V _{GH}	Ta=25°C	-	15.0	-	V
Module Driving Voltage	V _{EE}	Ta=25°C	-	-10.0	-	
Power Supply Current for LCM	I _{CC}	V _{CC} =3.3 V	-	-	TBD	mA

*NOTE1: Min. and Max. Voltage is mean within the range will has optimum contrast at Ta:25°C

Typ. Voltage is specified as module driving condition: Ta=25°C, V_{OP} at Optimum Contrast, the measuring condition as below, this value is **HYES** recommend when customer change the set condition , the V_{LCD} will be change.

*NOTE2 :

Measuring Condition:

Standard Value MAX.

T_a = 25°C

V_{CC} - GND = 3.3V

Display Pattern = Checkered pattern

2-2.1 Back-light only Specification

PARAMETER	SYMBOL	MIN	TYP	MAX	Unit	Test Condition	NOTE
Supply Current	I _f	-	-	60	mA	Ta=25°C	-
Supply Voltage	V _f	-	23.1	-	V	Ta=25°C	-
Brightness	Br	4300	-	-	cd/m ²	Ta=25°C I _f =20mA	-
Half-Life Time	L _f	-	10000	-	hrs	Ta=25°C	1

Note 1 : The “ Half-Life Time ”is defined as the module brightness decrease to 50% original brightness.

Date : Feb. 28, 2007

TECHNICAL SPECIFICATION

HYES

LCM

HT5702UL

Page 8 of 21

2-3 AC Characteristics

Digital Parallel RGB interface (960x240 resolution)

PARAMETER	Symbol	Min.	Typ.	Max.	Unit	
CLK period	T_{OSC}	-	156	-	ns	
Data setup time	T_{SU}	12	-	-	ns	
Data hold time	T_{HD}	12	-	-	ns	
IHS period	T_H	-	408	-	T_{OSC}	
IHS pulse width	T_{HS}	5	30	-	T_{OSC}	
IHS rising time	T_{Cr}	-	-	700	ns	
IHS falling time	T_{Cf}	-	-	300	ns	
IVS pulse width	T_{VS}	1	3	5	T_H	
IVS rising time	T_{Vr}	-	-	700	ns	
IVS falling time	T_{Vf}	-	-	1.5	μs	
IVS falling to IHS rising time for odd field	T_{HVO}	1	-	-	T_{OSC}	
IVS falling to IHS falling time for even field	T_{HVE}	1	-	-	T_{OSC}	
IVS-DEN time	NTSC	T_{VSE}	-	18	-	T_H
	PAL	T_{VSE}	-	26	-	T_H
IHS-DEN time	T_{HE}	36	68	88	T_{OSC}	
DEN pulse width	T_{EP}	-	320	-	T_{OSC}	
DEN-STH time	T_{DES}	-	1	-	T_{OSC}	
IVS period	NTSC	-	262.5	-	T_H	
	PAL	-	312.5	-	T_H	

Note:

(1)When SYNC mode is used, 1st data start from 68th CLK after IHS falling.

2-4 Interface Timing Chart

- Digital Parallel RGB

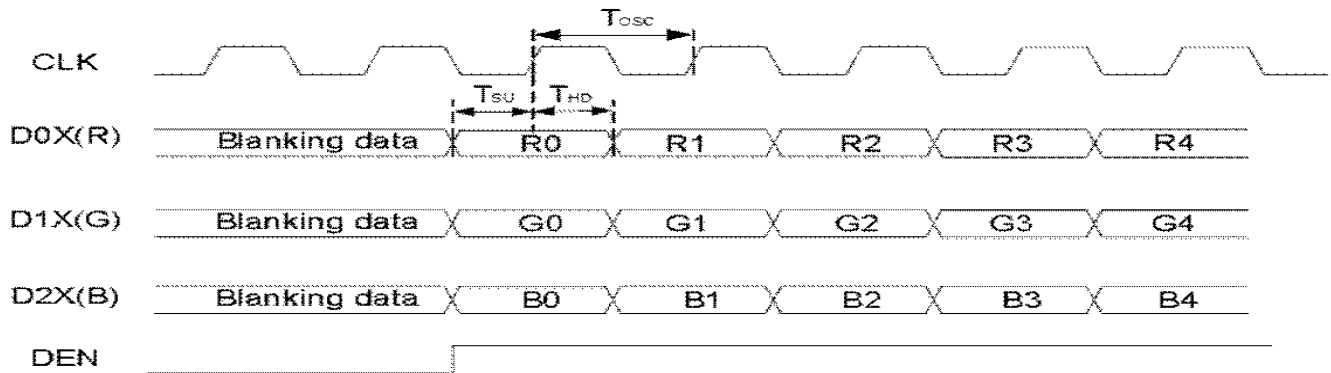

8.1.2.1 IHS and IVS timing

- Odd field

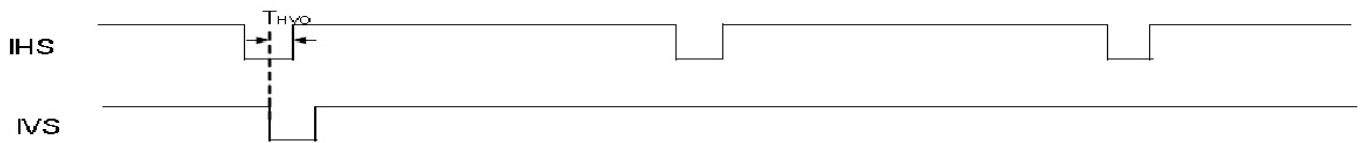

- Even field

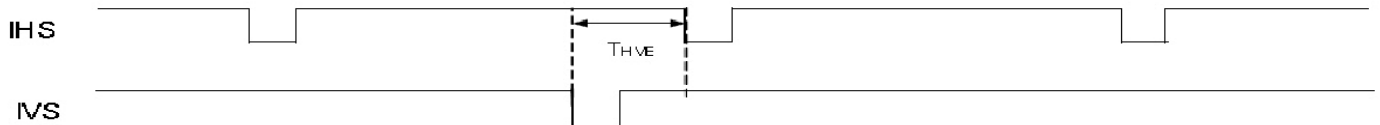

8.1.2.2 IHS and horizontal control timing waveform

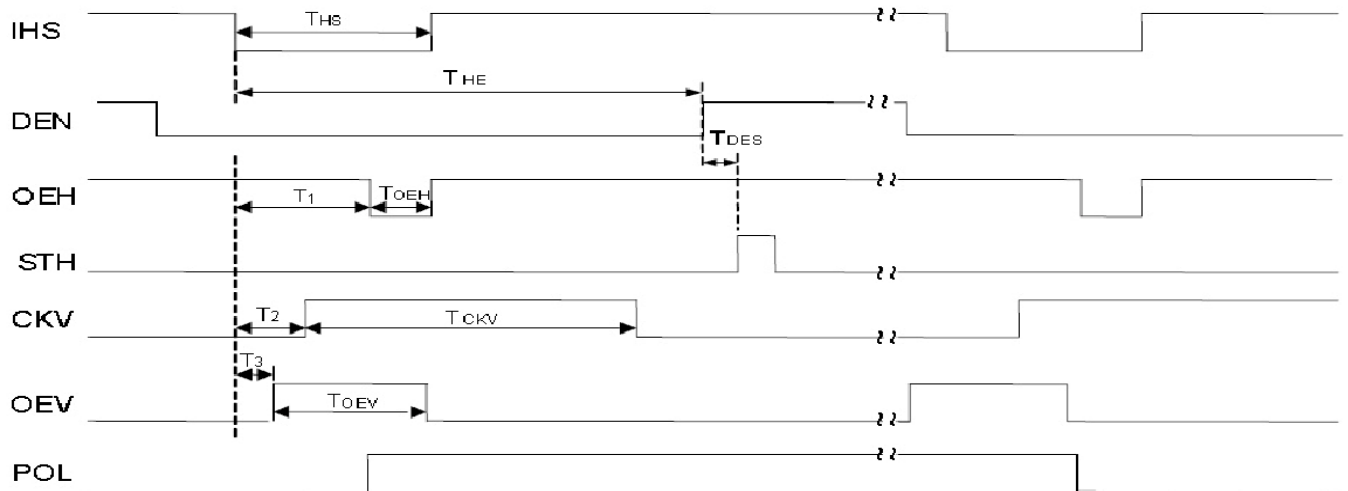

Date : Feb. 28, 2007

TECHNICAL SPECIFICATION

HYES

LCM

HT5702UL

Page 10 of 21

3. OPTICAL CHARACTERISTICS

3.1 Characteristics

Electrical and Optical Characteristics

No.	Item	symbol / temp.		Min.	Typ.	Max.	Unit	Note	
2	Response Time	Tr	25 °C	-	15	30	ms	2	
		Tf	25 °C	-	35	50			
3	Viewing Angle	Front-Rear	$\Theta 1$	$\Phi = 270^\circ$	-15	-	35	degree	3
		Left-Right	$\Theta 2$		-45	-	45		
4	Contrast Ratio	Cr	25 °C	150	250	-	-	4	
5	Red x-code	Rx	25 °C	TBD	TBD	TBD	-	5	
	Red y-code	Ry		TBD	TBD	TBD			
	Green x-code	Gx		TBD	TBD	TBD			
	Green y-code	Gy		TBD	TBD	TBD			
	Blue x-code	Bx		TBD	TBD	TBD			
	Blue y-code	By		TBD	TBD	TBD			
	White x-code	Wx		TBD	TBD	TBD			
	White y-code	Wy		TBD	TBD	TBD			
	Brightness	Y		-	-	-			cd/m ²
6	Brightness Uniformity		25 °C	-	-	-	%	6	

3.2 Definition of optical characteristics

Measurement condition :

Transmissive and Transflective type

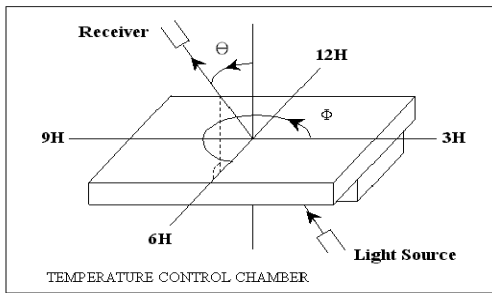

PHOTAL LCD-5000

[Note 1] Definition of LCD Driving Vop and Waveform :

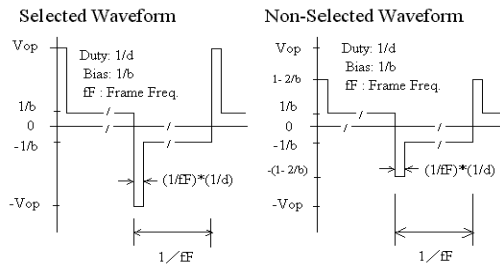
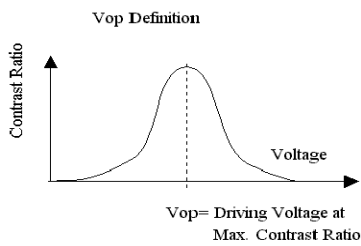

[Note 2] Definition of Response Time

for Positive type :

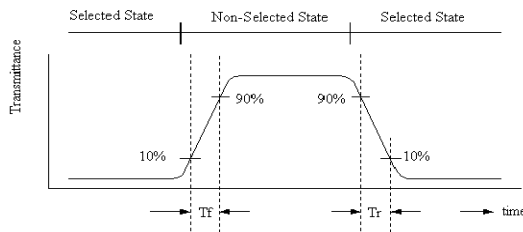

[Note 3] Definition of Viewing Angle :

[Note 4] Definition of Contrast Ratio :

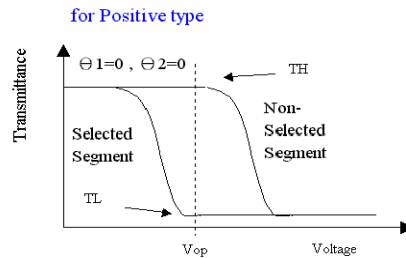
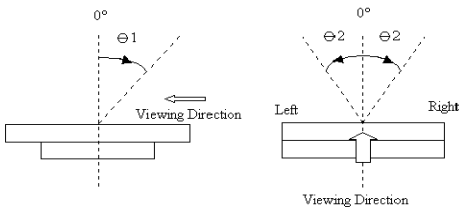

$$\text{Contrast Ratio} = \frac{T_H}{T_L}$$

Date : Feb. 28, 2007

TECHNICAL SPECIFICATION

HYES

LCM

HT5702UL

Page 12 of 21

[Note 5] Definition of measurement of Color Chromaticity and Brightness

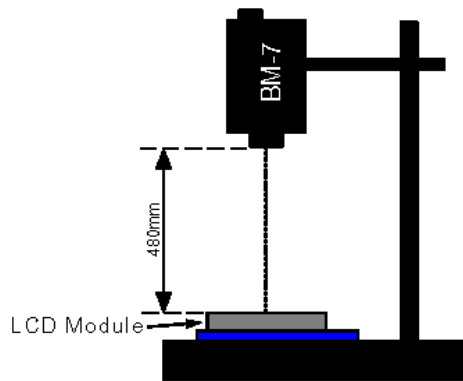

[Note 6] Definition of Brightness Uniformity

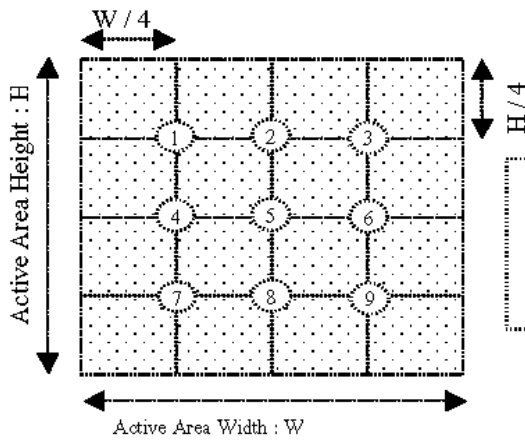

$$\text{Brightness Uniformity} = \frac{\text{Minimum Brightness of Point 1~9}}{\text{Maximum Brightness of Point 1~9}}$$

[Note 7] Definition of Measurement of Reflectance

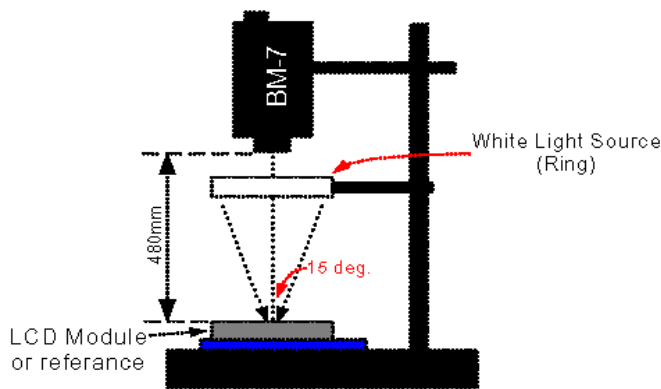

4. RELIABILITY :

Item No	Items	Condition	Remark
1	High temperature operating	70 °C , 200 hours	Finish product (With polarizer)
2	Low temperature operating	-20 °C , 200 hours	Finish product (With polarizer)
3	High temperature storage	80 °C , 200 hours	Finish product (With polarizer)
4	Low temperature storage	-30 °C , 200 hours	Finish product (With polarizer)
5	High temperature & humidity storage	60°C, 90%RH, 100 hours	Finish product (With polarizer)
6	Thermal Shock storage	-30°C , 30min.<=> 80°C , 30min. 10 Cycles	Finish product (With polarizer)
7	Vibration test	10 => 55 =>10 => 55 => 10 Hz , within 1 minute Amplitude : 1.5mm. 15 minutes for each Direction (X,Y,Z)	Finish product (With polarizer)
8	Drop test	Packed, 100CM free fall, 6 sides, 1 corner, 3edges	Finish product (With polarizer)
9	Life time	50,000 hours 25°C , 70%RH below , specification condition driving	Finish product (With polarizer)

* One single product test for only one item.

* Judgment after test : keep in room temperature for more than 2 hours.

- Current consumption < 2 times of initial value
- Contrast > 1/2 initial value
- Function : work normally

Date : Feb. 28, 2007

TECHNICAL SPECIFICATION

HYES

LCM

HT5702UL

Page 14 of 21

5. PRODUCT HANDLING AND APPLICATION

PRECAUTION FOR HANDLING LCM

- The LCD module contains a C-MOS LSI. People who operate the LCM should wear ESD protection equipment to prevent ESD hurt on products.
- Do not input any signal before power is turned on.
- Do not take LCM from its packaging bag until it is assembled.
- Peel off the LCM protective film slowly since static electricity may be generated.
- Pay attention to the humidity of the work shop, 50~60%RH is satisfactory.
- Use a non-leak iron for soldering LCM.
- Do not touch the display surface or connection terminals area with bare hands. Smudges on the display surface reduce the insulation between terminals.
- Cautions for soldering to LCM:
Condition for soldering I/O terminals:
Temperature at iron tip :280°C±10°C .
Soldering time : 3~4sec./ terminals.
Type of solder : Eutectic solder(rosin flux filled).

PRECAUTION IN USE OF LCD

- Do not contact or scratch the front surface and the contact pads of a LCD panel with hard materials such as metal or glass or with one's nail.
- To clean the surface , wipe it gently with soft cloth dampened by alcohol.
- Do not attempt to wipe off the contact pads.
- Keep LCD panels away from direct sunlight , also avoid them in high-temperature & high humidity environment for a long period.
- Do not drive LCD panels by DC voltage.
- Do not expose LCD panels to organic solvent.
- Liquid in LCD is hazardous substance. In case a contact with liquid crystal material is occurred, be sure to immediately wash such material away by soap and water.
- The polarizer is easily damaged and should be handle with special care. Don't press or rub it with hard objects.

PRECAUTION FOR STORING LCM

- To avoid degradation of the device , do not store the module under the conditions of direct sunlight , high temperature or high humidity . Keep the module in bags designed to prevent static electricity charging under low temperature / normal humidity conditions(avoid high temperature / high humidity and low temperature below 0°C)

USING ON MEDICAL CARE , SAFETY OR HAZARDOUS APPLICATION OR SYSTEM

- For the application in medical care, safety and hazardous products or systems, an authorization from HYES is required. HYES will not responsible for any damage or loss which caused by the products without any authorization given by HYES.
- This product is not allowed to be designed and used for military application and/or purpose.
- The delivery of this product to the countries and/or regions where the embargoes are imposed by U.N. is prohibited.

Date : Feb. 28, 2007

TECHNICAL SPECIFICATION

HYES

LCM

HT5702UL

Page 15 of 21

6. DATE CODE OF PRODUCTS

- Date code will be shown on each product :

- **Y MM DD - XXX**

Year Month Day - Production lots

- Example: 2 1 2 2 3 - 0 0 3 ==>Year 2002, Dec.,23rd , Batch no.03

7. PACKING

Instruction of lot number:

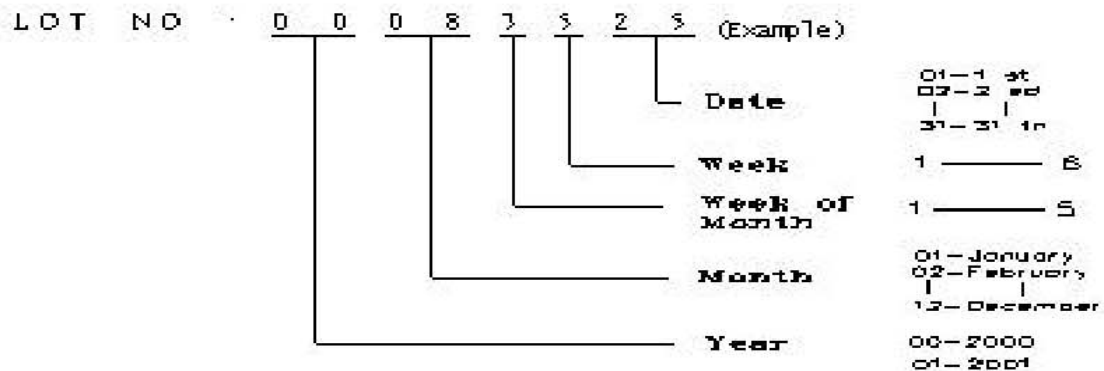

Label of carton:

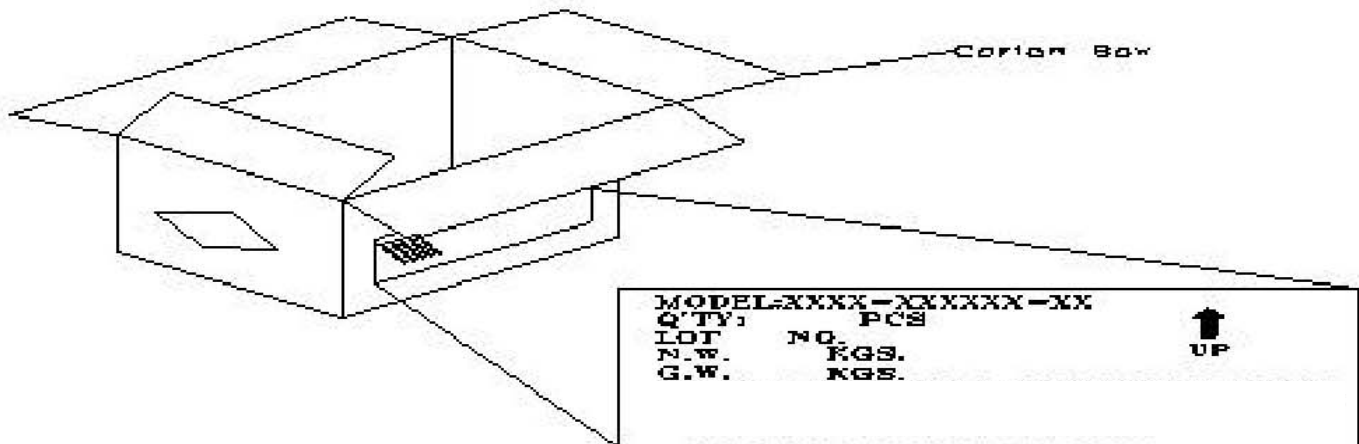

Packing tray must be stacked with alternated direction to each others.
 To tacks packing trays in same direction will cause product damaged.

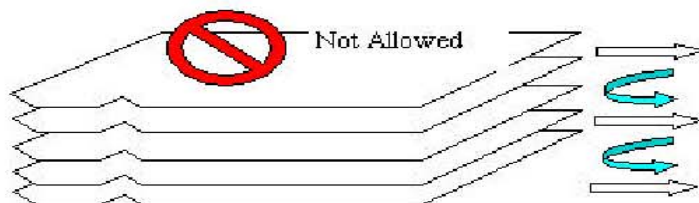
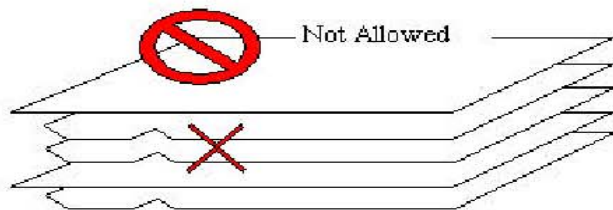

Date : Feb. 28, 2007

TECHNICAL SPECIFICATION

HYES

LCM

HT5702UL

Page 17 of 21

8. INSPECTION STANDARD

8.1. QUALITY :

THE QUALITY OF GOODS SUPPLIED TO PURCHASER SHALL COME UP TO THE FOLLOWING STANDARD.

8.1.1. THE METHOD OF PRESERVING GOODS

AFTER DELIVERY OF GOODS FROM **HYES** TO PURCHASER. PURCHASER SHALL CONTROL THE LCM AT -10 °C ~ 40 °C ,AND IT MIGHT BE DESIRABLE TO KEEP AT THE NORMAL ROOM TEMPERATURE AND HUMIDITY UNTIL INCOMING INSPECTION OR THROWING INTO PROCESS LINE.

8.1.2. INCOMING INSPECTION

(A) THE METHOD OF INSPECTION

IF PURCHASER MAKE AN INCOMING INSPECTION , A SAMPLING PLAN SHALL BE APPLIED ON THE CONDITION THAT QUALITY OF ONE DELIVERY SHALL BE REGARDED AS ONE LOT.

(B) THE STANDARD OF QUALITY

ISO-2859-1 (or MIL-STD-105D) , LEVEL II SINGLE PLAN.

CLASS	AQL(%)
CRITICAL	0.4 %
MAJOR	0.65 %
MINOR	1.5 %
TOTAL	1.5 %

EVERY ITEM SHALL BE INSPECTED ACCORDING TO THE CLASS.

(C) MEASURE

IF AS THE RESULT OF ABOVE RECEIVING INSPECTION , A LOT OUT IS DISCOVERED. PURCHASER SHALL BE INFORM SELLER OF IT WITHIN SEVEN DAYS. BUT FIRST SHIPMENT WITHIN FOURTEEN DAYS.

8.1.3. WARRANTY POLICY

HYES WILL PROVIDE ONE-YEAR WARRANTY FOR THE PRODUCTS ONLY IF UNDER SPECIFICATION OPERATING CONDITIONS. **HYES** WILL REPLACE NEW PRODUCTS FOR THESE DEFECT PRODUCTS WHICH UNDER WARRANTY PERIOD AND BELONG TO THE RESPONSIBILITY OF **HYES**.

8.2. CHECKING CONDITION

8.2.1. CHECKING DIRECTION SHALL BE IN THE 45 DEGREE AREA TO FACE THE SAMPLE.

8.2.2. CHECKER SHALL SEE OVER 30 cm. WITH BARE EYES FAR FROM SAMPLE AND USING 2 PCS. OF 20W FLUORESCENT LAMP.

Date : Feb. 28, 2007

TECHNICAL SPECIFICATION

HYES

LCM

HT5702UL

Page 18 of 21

8.3. INSPECTION PLAN :

CLASS	ITEM	JUDGEMENT	CLASS
PACKING & INDICATE	1. OUTSIDE AND INSIDE PACKAGE	"MODEL NO." , "LOT NO." AND "QUANTITY" SHOULD INDICATE ON THE PACKAGE.	Minor
	2. MODEL MIXED AND QUANTITY	OTHER MODEL MIXED.....REJECTED QUANTITY SHORT OR OVER.....REJECTED	Critical
	3. PRODUCT INDICATION	"MODEL NO." SHOULD INDICATE ON THE PRODUCT	Major
ASSEMBLY	4. DIMENSION, LCD GLASS SCRATCH AND SCRIBE DEFECT.	ACCORDING TO SPECIFICATION OR DRAWING.	Major
APPEARANCE	5. VIEWING AREA	POLARIZER EDGE OR LCD'S SEALING LINE IS VISABLE IN THE VIEWING AREAREJECTED	Minor
	6. BLEMISH , BLACK SPOT , WHITE SPOT IN THE LCD AND LCD GLASS CRACKS	ACCORDING TO STANDARD OF VISUAL INSPECTION (INSIDE VIEWING AREA)	Minor
	7. BLEMISH , BLACK SPOT WHITE SPOT AND SCRATCH ON THE POLARIZER	ACCORDING TO STANDARD OF VISUAL INSPECTION (INSIDE VIEWING AREA)	Minor
	8. BUBBLE IN POLARIZER	ACCORDING TO STANDARD OF VISUAL INSPECTION (INSIDE VIEWING AREA)	Minor
	9. LCD'S RAINBOW COLOR	STRONG DEVIATION COLOR (OR NEWTON RING) OF LCD.....REJECTED. OR ACCORDING TO LIMITED SAMPLE (IF NEEDED, AND INSIDE VIEWING AREA)	Minor
ELECTRICAL	10. ELECTRICAL AND OPTICAL CHARACTERISTICS (CONTRAST , VOP , CHROMATICITY ... ETC)	ACCORDING TO SPECIFICATION OR DRAWING . (INSIDE VIEWING AREA)	Critical
	11. MISSING PATTERN	MISSING DOT , LINE , CHARACTERREJECTED	Critical
	12. SHORT CIRCUIT , WRONG PATTERN DISPLAY	NON DISPLAY , WRONG PATTERN DISPLAY , CURRENT CONSUMPTION OUT OF SPECIFICATION..... REJECTED	Critical
	13. PIN HOLE , PATTERN DEFORMITY	ACCORDING TO STANDARD OF VISUAL INSPECTION	Minor

Date : Feb. 28, 2007

TECHNICAL SPECIFICATION

HYES

LCM

HT5702UL

Page 19 of 21

8.4. STANDARD OF VISUAL INSPECTION

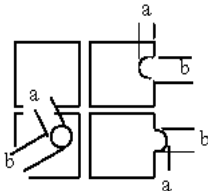
NO.	CLASS	ITEM	JUDGEMENT																									
8.4.1	MINOR	<ul style="list-style-type: none"> · BLEMISH · BLACK SPOT · WHITE SPOT IN THE LCD. · BLEMISH · BLACK SPOT · WHITE SPOT AND SCRATCH ON THE POLARIZER 	<p>(A) ROUND TYPE: unit : mm.</p> <table border="1"> <thead> <tr> <th>DIAMETER (mm.)</th> <th>ACCEPTABLE Q'TY</th> </tr> </thead> <tbody> <tr> <td>$\Phi \leq 0.1$</td> <td>DISREGARD</td> </tr> <tr> <td>$0.1 < \Phi \leq 0.2$</td> <td>2</td> </tr> <tr> <td>$0.2 < \Phi \leq 0.25$</td> <td>1</td> </tr> <tr> <td>$0.25 < \Phi$</td> <td>0</td> </tr> </tbody> </table> <p>NOTE: $\Phi = (\text{LENGTH} + \text{WIDTH})/2$</p> <p>(B) LINER TYPE: unit : mm.</p> <table border="1"> <thead> <tr> <th>LENGTH</th> <th>WIDTH</th> <th>ACCEPTABLE Q'TY</th> </tr> </thead> <tbody> <tr> <td>-----</td> <td>$W \leq 0.03$</td> <td>DISREGARD</td> </tr> <tr> <td>$L \leq 5.0$</td> <td>$0.03 < W \leq 0.05$</td> <td>3</td> </tr> <tr> <td>$L \leq 5.0$</td> <td>$0.05 < W \leq 0.07$</td> <td>1</td> </tr> <tr> <td>-----</td> <td>$0.07 < W$</td> <td>FOLLOW ROUND TYPE</td> </tr> </tbody> </table>	DIAMETER (mm.)	ACCEPTABLE Q'TY	$\Phi \leq 0.1$	DISREGARD	$0.1 < \Phi \leq 0.2$	2	$0.2 < \Phi \leq 0.25$	1	$0.25 < \Phi$	0	LENGTH	WIDTH	ACCEPTABLE Q'TY	-----	$W \leq 0.03$	DISREGARD	$L \leq 5.0$	$0.03 < W \leq 0.05$	3	$L \leq 5.0$	$0.05 < W \leq 0.07$	1	-----	$0.07 < W$	FOLLOW ROUND TYPE
DIAMETER (mm.)	ACCEPTABLE Q'TY																											
$\Phi \leq 0.1$	DISREGARD																											
$0.1 < \Phi \leq 0.2$	2																											
$0.2 < \Phi \leq 0.25$	1																											
$0.25 < \Phi$	0																											
LENGTH	WIDTH	ACCEPTABLE Q'TY																										
-----	$W \leq 0.03$	DISREGARD																										
$L \leq 5.0$	$0.03 < W \leq 0.05$	3																										
$L \leq 5.0$	$0.05 < W \leq 0.07$	1																										
-----	$0.07 < W$	FOLLOW ROUND TYPE																										
8.4.2	MINOR	BUBBLE IN POLARIZER	<p style="text-align: right;">unit : mm.</p> <table border="1"> <thead> <tr> <th>DIAMETER</th> <th>ACCEPTABLE Q'TY</th> </tr> </thead> <tbody> <tr> <td>$\Phi \leq 0.15$</td> <td>DISREGARD</td> </tr> <tr> <td>$0.15 < \Phi \leq 0.5$</td> <td>2</td> </tr> <tr> <td>$0.5 < \Phi$</td> <td>0</td> </tr> </tbody> </table>	DIAMETER	ACCEPTABLE Q'TY	$\Phi \leq 0.15$	DISREGARD	$0.15 < \Phi \leq 0.5$	2	$0.5 < \Phi$	0																	
DIAMETER	ACCEPTABLE Q'TY																											
$\Phi \leq 0.15$	DISREGARD																											
$0.15 < \Phi \leq 0.5$	2																											
$0.5 < \Phi$	0																											
8.4.3	MINOR	PIN HOLE · PATTERN DEFORMITY	<div style="display: flex; align-items: center;">  <table border="1" style="margin-left: 20px;"> <thead> <tr> <th colspan="2">DIAMETER</th> <th>ACC. Q'TY</th> </tr> </thead> <tbody> <tr> <td>$\Phi \leq 0.1$</td> <td></td> <td>DISREGARD</td> </tr> <tr> <td>$0.1 < \Phi \leq 0.25$</td> <td></td> <td>3</td> </tr> <tr> <td>$0.25 < \Phi$</td> <td></td> <td>0</td> </tr> </tbody> </table> <p style="text-align: center;">$\Phi = (a+b)/2$</p> </div> <p style="text-align: right;">unit : mm.</p>	DIAMETER		ACC. Q'TY	$\Phi \leq 0.1$		DISREGARD	$0.1 < \Phi \leq 0.25$		3	$0.25 < \Phi$		0													
DIAMETER		ACC. Q'TY																										
$\Phi \leq 0.1$		DISREGARD																										
$0.1 < \Phi \leq 0.25$		3																										
$0.25 < \Phi$		0																										

Date : Feb. 28, 2007

TECHNICAL SPECIFICATION

HYES

LCM

HT5702UL

Page 20 of 21

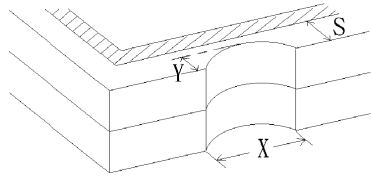
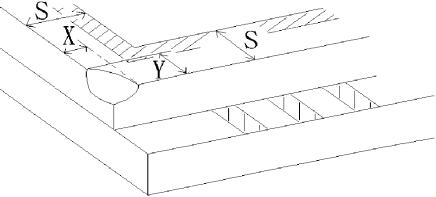
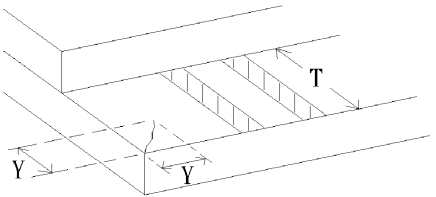
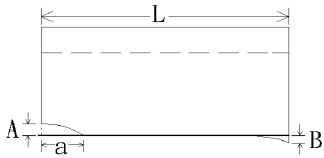
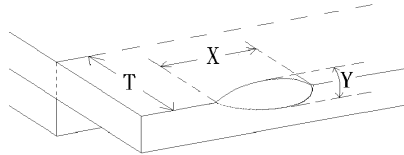
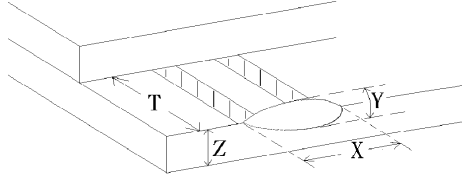
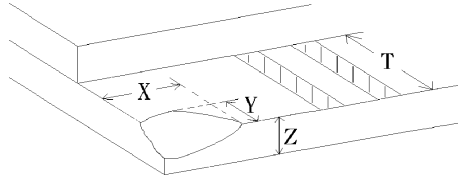
NO.	CLASS	ITEM	JUDGEMENT
8.4.4	MINOR	CHIPPING	 $Y > S$ REJ.
8.4.5	MINOR	CHIPPING	 $X \text{ or } Y > S$ REJ.
8.4.6	MAJOR	GLASS CRACK	 $Y > (1/2) T$ REJ.
8.4.7	MAJOR	SCRIBE DEFECT	 <ol style="list-style-type: none"> $a > L/3$, $A > 1.5\text{mm}$. REJ. B : ACCORDING TO DIMENSION
8.4.8	MINOR	CHIPPING (ON THE TERMINAL AREA)	 $\Phi = (x+y)/2 > 2.5 \text{ mm}$ REJ.
8.4.9	MINOR	CHIPPING (ON THE TERMINAL SURFACE)	 $Y > (1/3) T$ REJ.
8.4.10	MINOR	CHIPPING	 $Y > T$ REJ.

Date : Feb. 28, 2007

TECHNICAL SPECIFICATION

HYES

LCM

HT5702UL

Page 21 of 21